

TELEFUNKEN
LIGHT2022

LICHT FÜR ALLE
ANSPRÜCHE



EINE STARKE MARKE

A Strong brand / Une marque forte

Seit über 100 Jahren steht die Marke TELEFUNKEN für hochwertige Qualität, Zuverlässigkeit und herausragende Leistungen gepaart mit modernem Design und hoher Benutzerfreundlichkeit. Bis heute sorgt die große Bekanntheit der Marke mit ihren Werten für Sicherheit und Vertrauen beim Kunden.

Auch in diesem Jahr haben wir unser neues Funktionsleuchten-Sortiment mit dem Anspruch entwickelt, einen echten Mehrwert für unsere Kunden zu schaffen und einmal mehr das bekannte Marken-Image zu repräsentieren. Wir verstehen dies als ein Leistungsversprechen, das wir gegenüber unseren Partnern und Kunden einlösen wollen. Mit unserem Produkt-Portfolio

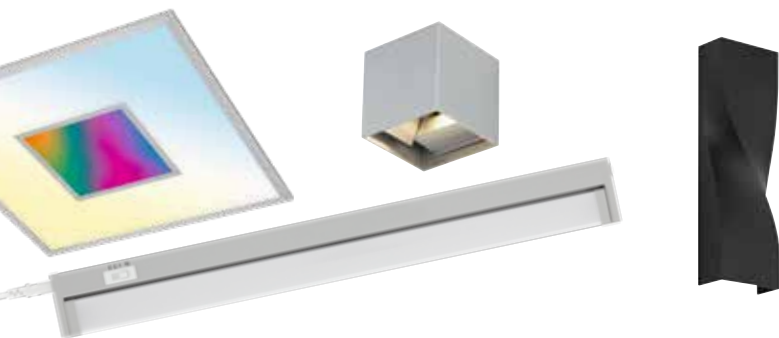

For over 100 years, the TELEFUNKEN brand has stood for premium quality, reliability and outstanding performance, together with modern design and excellent user friendliness. To this day, the brand's strong name recognition ensures that customers still see us as a safe and trustworthy pair of hands.

This year we have also developed a new range of functional lights, with the aim of generating real added value for our customers and enhancing our well-known brand image even further. We see this image as a performance pledge to our partners and customers that we want to uphold. Our product portfolio under the TELEFUNKEN brand is particularly aimed at those customers who are looking for innovative lighting solutions by a premium brand.

The clear and intuitively understandable POS concept supports customers in their purchase decision in an optimal way by conveying the versatile application possibilities of our lights as well as the simple mounting options in a self-explanatory way. With the brand TELEFUNKEN we offer easy access to modern LED lighting solutions, that make your home more bright, comfortable and safe. TELEFUNKEN – Intelligent lighting solutions for a modern home.

unter der Marke TELEFUNKEN richten wir uns insbesondere an diejenigen Kunden, die innovative Lichtlösungen in Markenqualität suchen.

Durch eine klare und intuitiv zu verstehende POS-Konzeption, welche die vielseitigen Einsatzmöglichkeiten unserer Leuchten, sowie die einfachen Montagemöglichkeiten selbsterklärend vermittelt, wird der Kunde in seiner Kaufentscheidung optimal unterstützt. Wir bieten mit der Marke TELEFUNKEN einen einfachen Zugang zu modernen LED-Lichtlösungen, die durch ihre intelligenten Funktionen das Zuhause heller, komfortabler und sicherer machen. TELEFUNKEN – Intelligente Lichtlösungen für ein modernes Zuhause.

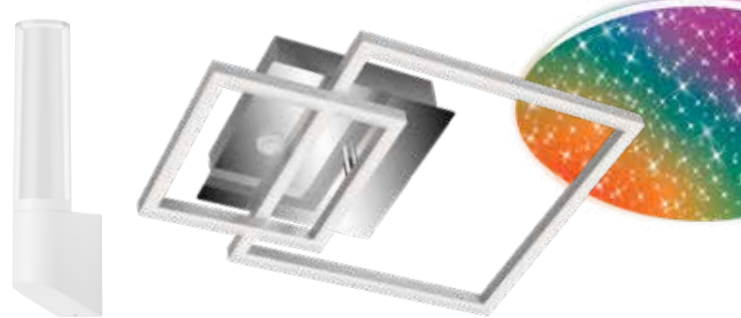

Depuis plus de 100 ans, la marque TELEFUNKEN est un gage de qualité supérieure, de fiabilité et de prestations d'excellence, associée à l'image d'un design moderne et d'une facilité d'utilisation hors norme. Encore aujourd'hui, la renommée de la marque et ses valeurs sont un repère de sécurité et de confiance auprès des clients.

De nouveau cette année, nous avons révisé notre assortiments de luminaires fonctionnels dans l'esprit d'apporter une véritable plus-value à nos clients et de représenter une fois de plus l'image de marque de notre enseigne. Pour nous, c'est une garantie de performance que nous souhaitons proposer à nos clients et partenaires. Avec notre portfolio de produits sous la marque TELEFUNKEN, nous ciblons notamment des clients à la recherche de solutions d'éclairage innovantes portant la qualité de notre marque.

Grâce à la conception claire et intuitive de notre point de vente, qui traduit les options d'utilisation multiples de nos lampes et leur simplicité de montage, le client sera accompagné de manière optimale dans sa décision d'achat. Nous offrons avec la marque TELEFUNKEN un accès facile aux solutions d'éclairage LED modernes qui grâce à ses fonctions intelligentes font de l'habitat un espace plus lumineux, plus confortable et plus sûr. TELEFUNKEN – des solutions d'éclairage LED intelligentes pour un habitat moderne.

BRILONER ÖKO BILANZ

Briloner eco-balance

Die Weichen stehen auf Wachstum - nachhaltigem Wachstum. Der wohl bezeichnendste Faktor dafür ist unser neues Functional Light Konzept; neue, ausgefeilte Produkte in bekannter Blisterver... nein! In vollständig neu durchdachtem, nachhaltigen Kartonagenkonzept! Überzeugen Sie sich. Weniger ist Pappe!

Sustainable growth – a trend that's growing sustainably. Our most striking contribution to this trend is probably our new functional light concept; new, sophisticated products that come in blister packs... or not! We use a completely rethought, sustainable, paper-based packaging concept. It's a done deal. When it comes to packaging, less is definitely more!

L'avenir est à la croissance – une croissance durable. L'élément le plus révélateur de cette vision est notre nouveau concept Functional Light ; de nouveaux produits sophistiqués emballés sous blister... non ! Dans un concept d'emballage entièrement revisité en carton durable ! Voyez par vous-même. Ça cartonne !



INHALT

Content / Contenu

MEGASELLER		08
FUNCTIONAL LIGHT		24
SENSORLEUCHTEN		70
Sensor lights / Lampes avec détecteur		
DEKORATIVE AUSSENLEUCHTEN		86
Decorative outdoor lights / Luminaires décoratifs d'extérieur		
TECHNISCHE AUSSENLEUCHTEN		124
Technical outdoor lights / Luminaires techniques d'extérieur		

WILLKOMMEN

Welcome / Bienvenue

Willkommen im neu strukturierten TELEFUNKEN Showroom am Standort Brilon. Auf über 100m² findet das TELEFUNKEN-Produktportfolio seinen Platz. Bekannte Sortimente wurden genau so integriert, wie drei neue Einheiten Functional Light mit innovativem Verpackungs- und POS-Konzept. Durch eine klare und intuitive POS-Konzeption,

können wir die vielseitigen Einsatzbereiche aufzeigen. Neben dekorativen Elementen liegt unser Fokus auf den verschiedenen selbsterklärenden POS-Alternativen und Montagemöglichkeiten. Hier denken wir für Sie auch gerne mal um die Ecke und beraten Sie individuell.

Wir freuen uns auf Ihren Besuch!

Welcome to the newly remodelled TELEFUNKEN showroom at the Brilon site. Here you can find our TELEFUNKEN product portfolio spread out over more than 100m². There's room for our well-known ranges, as well as three new functional light units with their innovative packaging and point-of-sale (POS) concepts. Our clear and intuitive



POS concept allows us to demonstrate the diverse ways of using our products. In addition to the decorative side of things, we also focus on conveying the range of POS alternatives and mounting options in a self-explanatory way. We're happy to think outside the box for you and give you tailored advice.

We look forward to your visit!

Bienvenue au tout nouveau showroom TELEFUNKEN de Brilon. Notre portfolio de produits TELEFUNKEN se décline sur plus de 100m². Retrouvez également d'autres assortiments connus, tout comme trois nouvelles unités Functional Light avec un concept innovant d'emballage et de point de vente. La conception épurée et intuitive du point de vente permet de présenter

des domaines d'utilisation divers. Parallèlement aux éléments décoratifs, notre attention s'est également portée sur différentes alternatives de POS et options de montages intuitives. Nous arrivons ici à nous projeter, pour vous conseiller personnellement. **Nous attendons votre visite avec impatience !**



NEU IM SORTIMENT



Das besondere Highlight unserer Sortimentserweiterung „MEGASELLER“ sind die Magic-Leuchten. Noch nie dagewesene Lichteffekte und Farbspiele, weit über die klassische RGB-Funktion hinaus, werden sie verzaubern – versprochen.

The main highlight of our new MEGASELLER product range is... Magic Lights. You'll be spellbound by our revolutionary lighting effects and nuanced colours that knock the socks off the conventional RGB offering – that's a promise!

L'atout particulier de notre extension d'assortiment „MEGASELLER“, ce sont les éclairages Magic. Les effets lumineux et les jeux de couleur sans précédent vont bien au-delà de la fonction RGB classique et vont vous enchanter, promesse tenue.

MEGASELLER

HIER HABEN WIR WAS AUS DEM HUT GEZAUBERT.

Look at what we've pulled out of the hat.
Tout droit sorti du chapeau.



MEGASELLER

LIGHTS
MAGIC CENTO

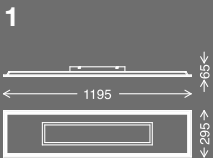

1 - 3 HIGH-LIGHTS

- RGB-Magic-Centerlight
- CCT-Funktion in der äußeren Lichtfläche
- Innen- und Außenlicht getrennt via inkludierter Fernbedienung schaltbar
- RGB-Magic-Centerlight
- CCT Function in the outer light surface
- Center light and main light separated via joined remote control
- RGB-Magic-Centerlight
- Fonction CCT dans la zone lumineuse extérieure
- Éclairage intérieur et extérieur contrôlé séparément par télécommande incluse

1. 320004TF EAN 4059709004594

Kunststoff-Metall silberfarbig

Plastic-metal silver | Plastique-métal argenté

Incl. 1x LED-Platine | 32,5W | 3.400lm

3.000K - 6.500K

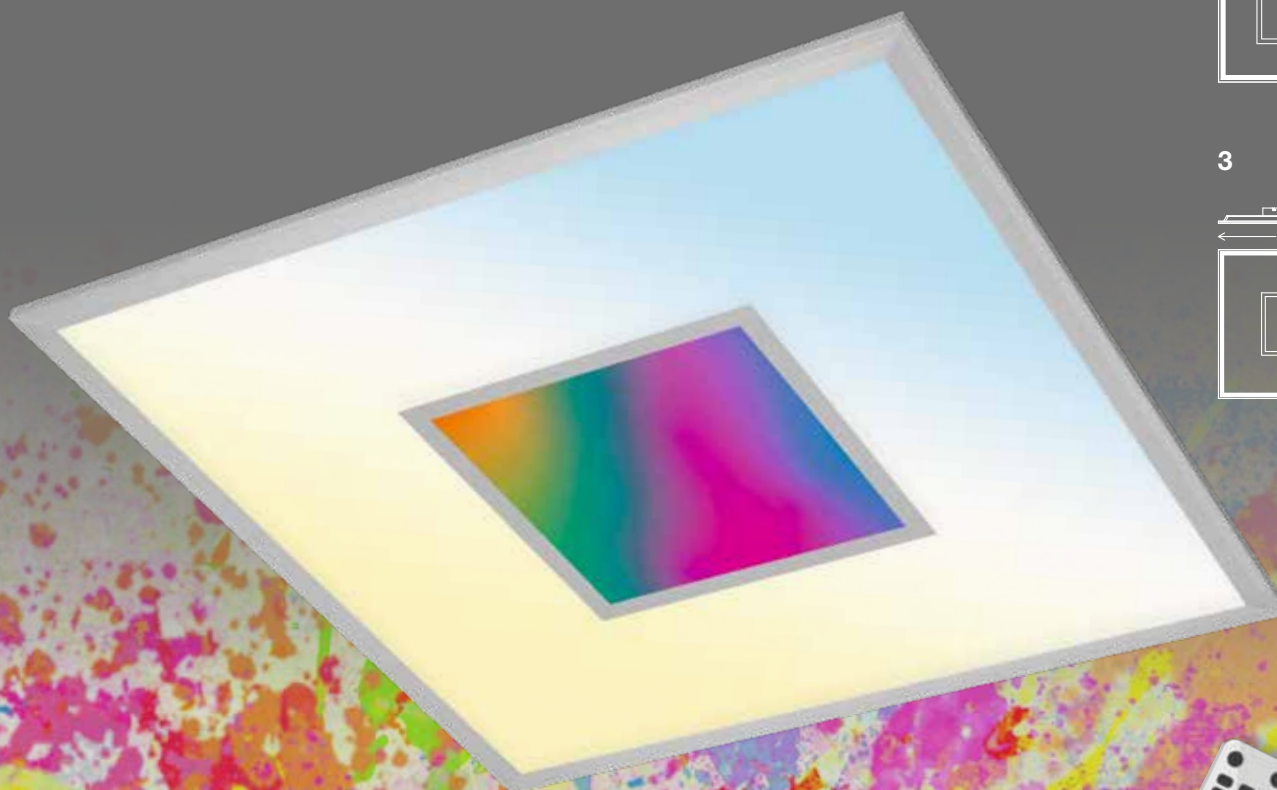
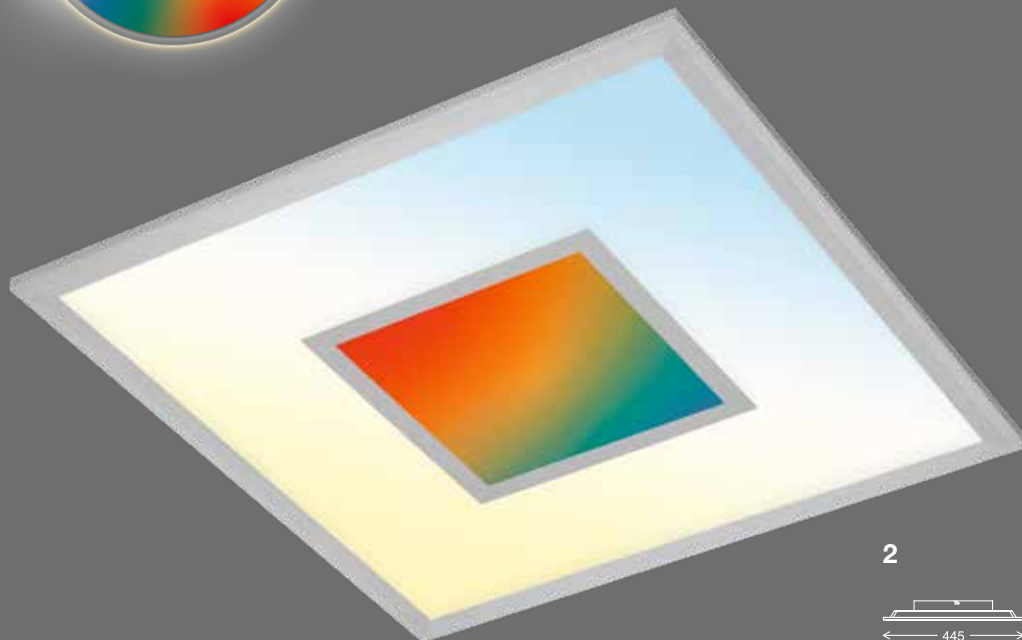

2

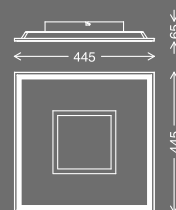

3



2. 319704TF EAN 4059709004563
Kunststoff-Metall silberfarbig
Plastic-metal silver | Plastique-métal argenté
Incl. 1x LED-Platine | 21W | 2.100lm
3.000K - 6.500K

3. 319804TF EAN 4059709004570
Kunststoff-Metall silberfarbig
Plastic-metal silver | Plastique-métal argenté
Incl. 1x LED-Platine | 32,5W | 3.400lm
3.000K - 6.500K

INCL.



NEU IM SORTIMENT

MEGASELLER

LIGHTS

MAGIC CENTO



2

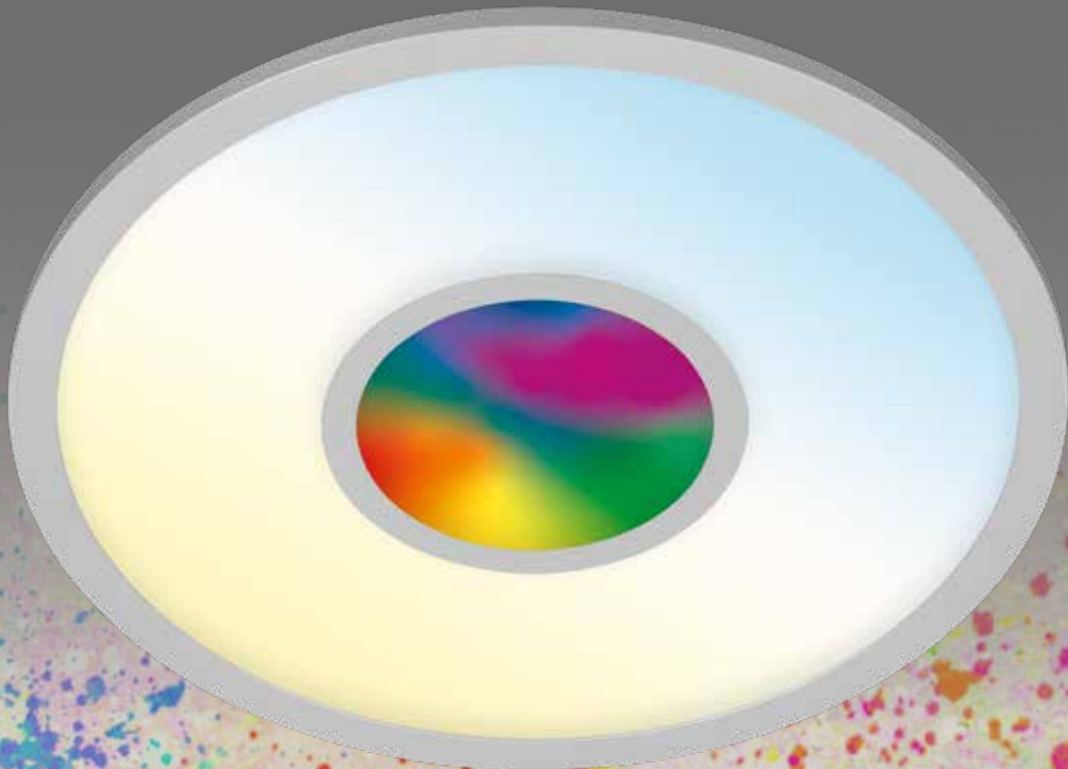

INCL.



1. 319904TF EAN 4059709004587
Kunststoff-Metall silberfarbig
Plastic-metal silver | Plastique-métal argenté
Incl. 1x LED-Platine 21W | 2.100lm
3.000K - 6.500K

2. 320104TF EAN 4059709004600
Kunststoff-Metall silberfarbig
Plastic-metal silver | Plastique-métal argenté
Incl. 1x LED-Platine | 21W | 2.100lm
3.000K - 6.500K

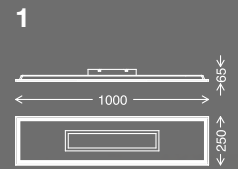

1-2 HIGHLIGHTS

- RGB-Magic-Centerlight
- CCT-Funktion in der äußeren Lichtfläche
- Innen- und Außenlicht getrennt via inkludierter Fernbedienung schaltbar
- RGB-Magic-Centerlight
- CCT Function in the outer light surface
- Center light and main light separated via joined remote control
- RGB-Magic-Centerlight
- Fonction CCT dans la zone lumineuse extérieure
- Éclairage intérieur et extérieur contrôlé séparément par télécommande incluse



MEGASELLER

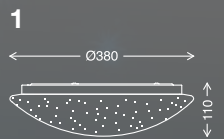

1 HIGH-LIGHTS

- RGB-Magic-Lichteffekt
- Cover mit Sternendekor
- Inkl. Fernbedienung
- RGB magic light effect
- Cover with star decoration
- Incl. remote control
- Effect lumineux RGB magique
- Covercle avec décor étoilé
- Télécommande incl.

INCL.



1. 602806TF EAN 4059709004556

Kunststoff weiß

Plastic white | Plastique blanc

Incl. 1x LED-Platine | 19W | 2.200lm

3.000K - 6.500K



LIGHTS
MAGIC SKY



MEGASELLER

LIGHTS
CENTERBACK



1



1 - 3 HIGH-LIGHTS

- Hochwertige Optik durch zweite, innenliegende RGB-Lichtfläche
- Innen- und Außenlicht (CCT) separat schaltbar
- Inkl. Fernbedienung

- High-quality optics through second, internal rgb light surface
- Center light and main light (cct) separately switchable
- Incl. remote control

- Optique de haute qualité grâce à une deuxième surface lumineuse rgb intérieure
- Éclairage intérieur et extérieur (CCT) commutable séparément.
- Télécommande incl.

1. 319605TF EAN 4059709004532

Kunststoff-Metall schwarz

Plastic-metal black | Plastique-métal noir
Incl. 1x LED-Platine | 24W | 2.200lm
3.000K - 6.500K

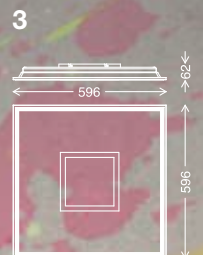
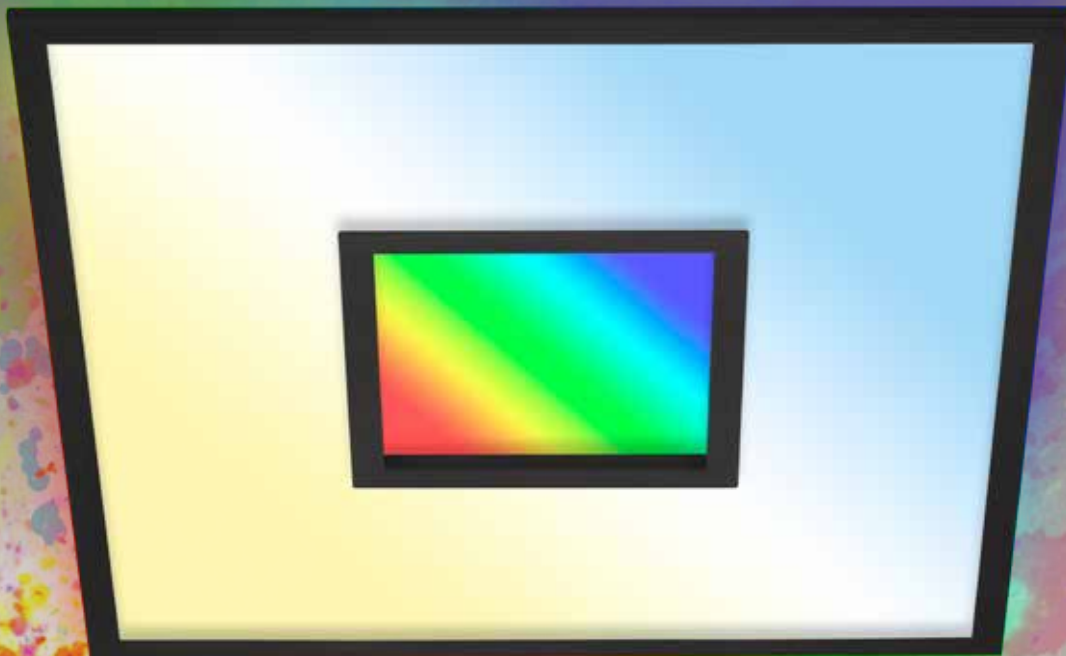
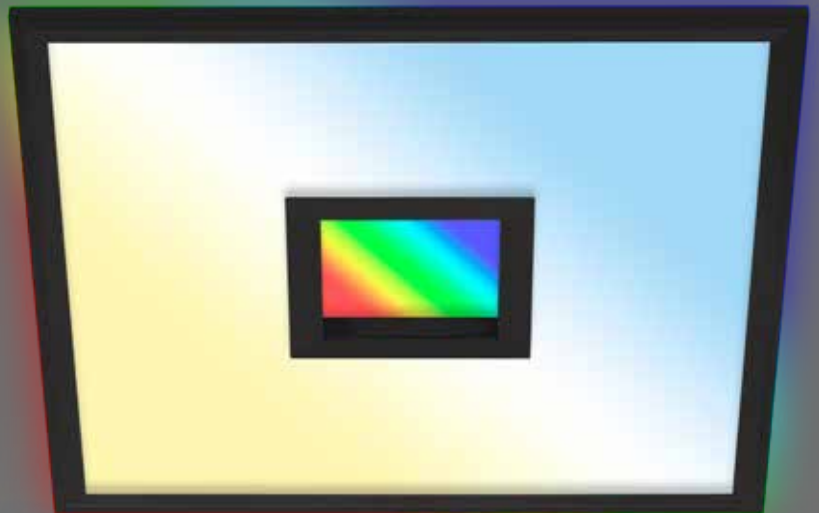
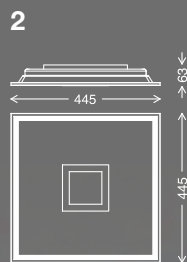

2. 319405TF EAN 4059709004495
Kunststoff-Metall schwarz
Plastic-metal black | Plastique-métal noir
Incl. 1x LED-Platine | 24W | 2.200lm
3.000K - 6.500K

3. 319505TF EAN 4059709004518
Kunststoff-Metall schwarz
Plastic-metal black | Plastique-métal noir
Incl. 1x LED-Platine | 36W | 3.800lm
3.000K - 6.500K

INCL.



MEGASELLER

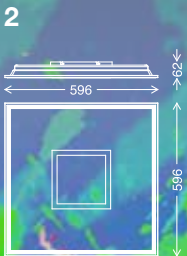
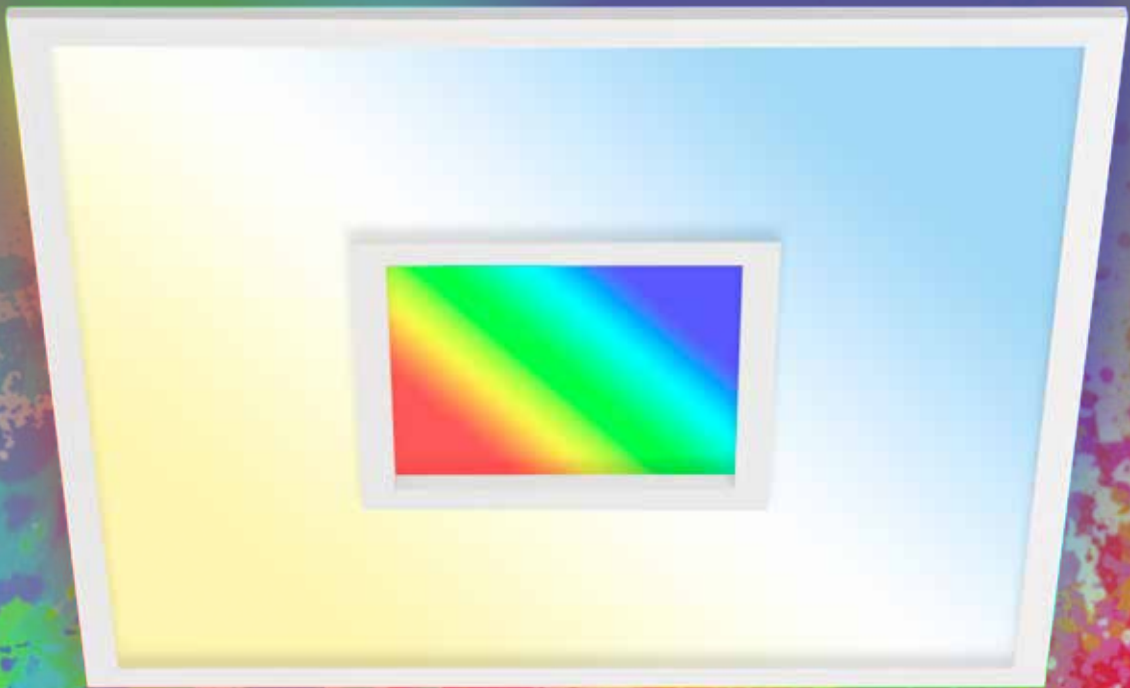

INCL.



1. 319406TF EAN 4059709004488
Kunststoff-Metall weiß
Plastic-metal white | Plastique-métal blanc
Incl. 1x LED-Platine | 24W | 2.200lm
3.000K - 6.500K

2. 319506TF EAN 4059709004501
Kunststoff-Metall weiß
Plastic-metal white | Plastique-métal blanc
Incl. 1x LED-Platine | 36W | 3.800lm
3.000K - 6.500K

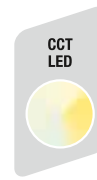

LIGHTS CENTERBACK

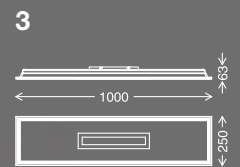

1-3 HIGH-LIGHTS

- Hochwertige Optik durch zweite, innenliegende RGB-Lichtfläche
- Innen- und Außenlicht (CCT) separat schaltbar
- Inkl. Fernbedienung
- High-quality optics through second, internal rgb light surface
- Center light and main light (cct) separately switchable
- Incl. remote control
- Optique de haute qualité grâce à une deuxième surface lumineuse rgb intérieure
- Éclairage intérieur et extérieur (CCT) commutable séparément.
- Télécommande incl.

3. 319606TF EAN 4059709004525

Kunststoff-Metall weiß

Plastic-metal white | Plastique-métal blanc

Incl. 1x LED-Platine | 24W | 2.200lm

3.000K - 6.500K

NEU IM SORTIMENT

MEGASELLER

LIGHTS
FRAMELIGHT



1



1 - 3 HIGH-LIGHTS

- Innenlicht CCT
- Außenlicht RGB
- Lichtflächen separat steuerbar
- Inkl. Fernbedienung

- Center light CCT
- Main light RGB
- Light surfaces separately controllable
- Incl. remote control

- Lumière intérieure CCT
- Éclairage externe RGB
- Surfaces lumineuses contrôlables séparément
- Télécommande incl.

1. 318906TF EAN 4059709004433

Kunststoff-Metall weiß

Plastic-metal white | Plastique-métal blanc

Incl. 1x LED-Platine | 24W | 2.400lm

3.000K - 6.500K

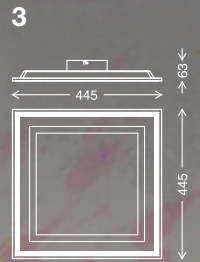
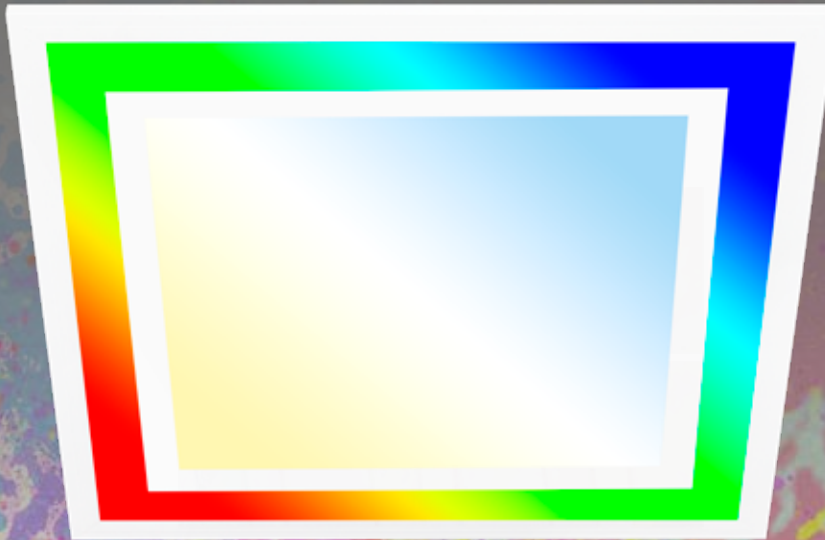
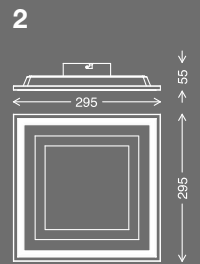
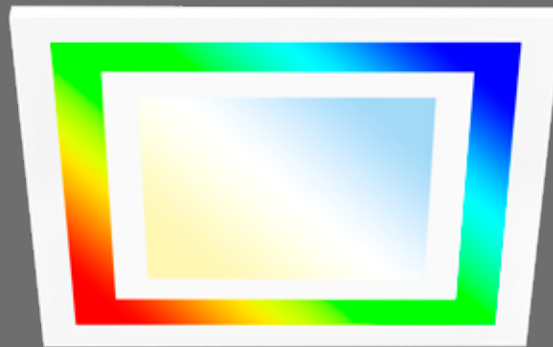
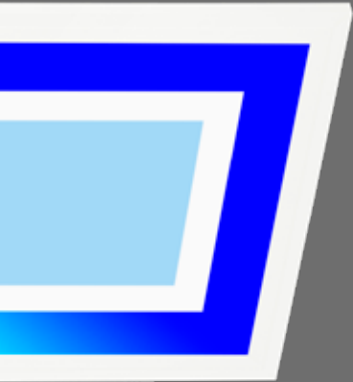

2. 318706TF EAN 4059709004419
Kunststoff-Metall weiß
 Plastic-metal white | Plastique-métal blanc
 Incl. 1x LED-Platine | 18W | 1.600lm
 3.000K - 6.500K

3. 318806TF EAN 4059709004426
Kunststoff-Metall weiß
 Plastic-metal white | Plastique-métal blanc
 Incl. 1x LED-Platine | 24W | 2.400lm
 3.000K - 6.500K

INCL.



MEGASELLER

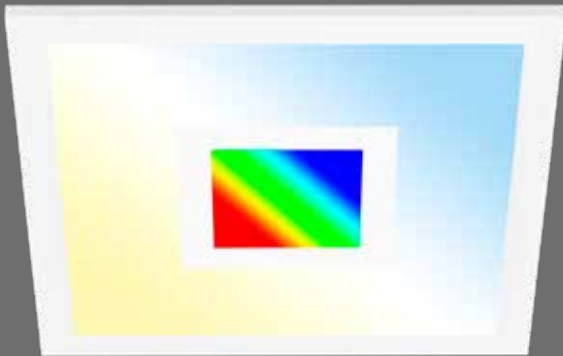

1

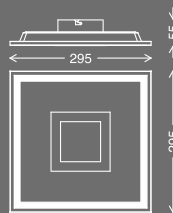

2

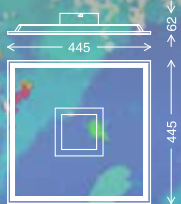

INCL.



1 - 4 HIGH-LIGHTS

- Innenlicht RGB
- Außenlicht CCT
- Lichtflächen separat steuerbar
- Inkl. Fernbedienung

- Center light RGB
- Main light CCT
- Light surfaces separately controllable
- Incl. remote control

- Lumière intérieure RGB
- Éclairage externe CCT
- Surfaces lumineuses contrôlables séparément
- Télécommande incl.

1. 319006TF EAN 4059709004440

Kunststoff-Metall weiß

Plastic-metal white | Plastique-métal blanc
 Incl. 1x LED-Platine | 16W | 1.500lm
 3.000K - 6.500K

2. 319106TF EAN 4059709004457

Kunststoff-Metall weiß

Plastic-metal white | Plastique-métal blanc
 Incl. 1x LED-Platine | 24W | 2.400lm
 3.000K - 6.500K

LIGHTS CENTERLIGHT



3

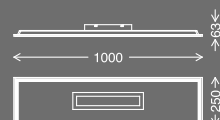

4

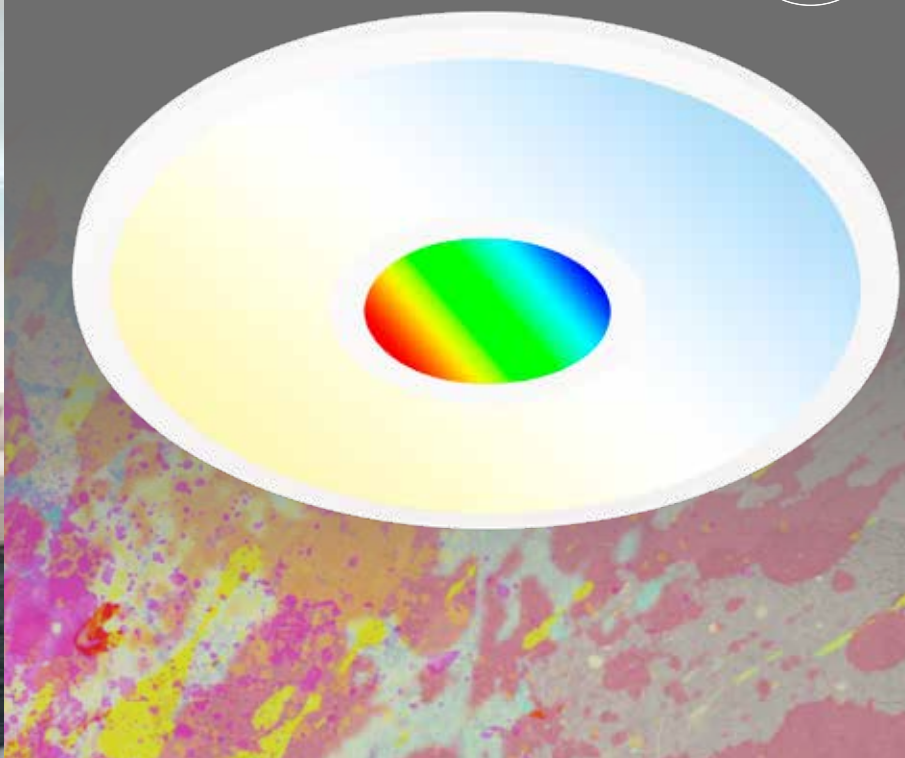
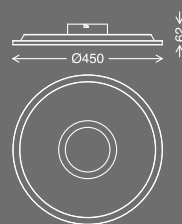

3. 319206TF EAN 4059709004464
Kunststoff-Metall weiß
 Plastic-metal white | Plastique-métal blanc
 Incl. 1x LED-Platine | 22W | 2.200lm
 3.000K - 6.500K

4. 319306TF EAN 4059709004471
Kunststoff-Metall weiß
 Plastic-metal white | Plastique-métal blanc
 Incl. 1x LED-Platine | 22W | 2.200lm
 3.000K - 6.500K



Hier haben wir nicht gekleckert, sondern geklotzt. Ein von A bis Z neu durchdachtes Sortiment mit innovativem und vor allem schlüssigen Kommunikationskonzept. Natürlich haben wir auch zahlreiche, technische Besonderheiten nicht vernachlässigt. Egal ob in der Küche, im Büro, dem Keller- aufgang oder der Garage: Wir bringen Licht ins Dunkel!

We've really gone the whole hog here. A range with an innovative and above all coherent communication concept, freshly reimagined from A to Z. And of course, we haven't neglected the vast technical side of things. Whether it's the kitchen, the office, the stairs to the basement or the garage: we bring light into the darkness!

Nous n'avons pas fait les choses à moitié. Un assortiment repensé de A à Z avec un concept de communication innovant et particulièrement convaincant. Naturellement, nous avons opté pour de nombreuses caractéristiques techniques. Pour la cuisine, le bureau, l'accès à la cave ou le garage : nous mettons en lumière les espaces sombres !

LICHTAKZENTE FÜR DIE DUNKELSTEN ECKEN.

Light accents for the darkest corners.

Des accents lumineux pour les coins les plus sombres.



Infrarot
infrared / infrarouge

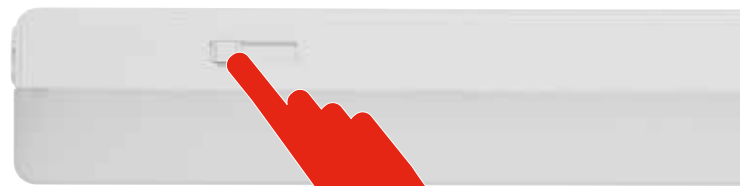

Stufenlos dimmbar
Infinitely dimmable / Dimmable en continu

POINT OF SALE

Unser Beitrag für
eine grünere Zukunft:
Karton statt Blister!



Our contribution to a greener future: Cardboard instead of blister! / Notre contribution à un avenir plus vert: Carton au lieu de blister !



Klick & Connect!

Verbindbar / connectable



Infrarot

infrared / infrarouge



Stufenlos dimmbar / Continuously dimmable / Dimmable en continu



3.000 K



4.000 K



6.000 K

Farbtemperaturwechsel / White tone management / Gestion des tonalités blanches

WAS DARF ES SEIN? LEUCHTEN, SO FLEXIBEL WIE MODERN.

What would you like? luminaires as flexible as modern.

Qu'est-ce qui vous ferait plaisir ? Des luminaires aussi flexibles que modernes.

Was darf es sein? Hervorragendes Arbeitslicht oder eine gemütliche Atmosphäre in der Küche?

Unsere hochwertigen Unterbauleuchten sind so flexibel, wie eine moderne Küche es erfordert. Um alle Küchengrößen zu beleuchten, bietet es sich an, unterschiedliche Größen einer Serie einzusetzen. Praktisch ist dabei die Verbindungsfunktion. Einzelleuchten werden zu einer Gruppe verbunden. Diese kann dann zentral gesteuert werden.

Infrarot-Sensoren vervollständigen die ausgereifte Technik und sorgen für eingeschaltetes Licht über den Arbeitsflächen, sobald der Sensor eine Handbewegung registriert. Die Farbtemperatur lässt sich steuern und die Leuchten sind per Wandschalter dimmbar oder verfügen über einen Wippschalter.

What will it be? Excellent working light or a cosy atmosphere in the kitchen?

Our high-quality undercabinet luminaires are as flexible as a modern kitchen requires them to be. In order to illuminate every size of kitchen flexibly, it is advisable to use different sizes from within one series. The connection function is particularly practical here. Individual luminaires are connected to form groups. These can then be controlled centrally.

Infrared sensors complete the sophisticated technology and ensure that the light above the work surfaces is switched on as soon as the sensor registers a hand movement. The colour temperature can be controlled and the luminaires can be dimmed with a wall switch or have a toggle switch.

Que souhaitez-vous? Une excellente lumière de travail ou une atmosphère chaleureuse dans la cuisine?

Nos luminaires de haute qualité sont aussi flexibles que l'exige une cuisine moderne. Afin d'éclairer toutes les tailles de cuisine de manière flexible, il est conseillé d'utiliser différentes tailles d'une série. La fonction de connexion est pratique. Les luminaires peuvent être utilisés à l'unité ou bien reliés à un groupe, lequel peut alors être contrôlé de manière centralisée.

Des capteurs infrarouges complètent cette technologie sophistiquée. Les luminaires situés au-dessus des plans de travail s'allument dès que le capteur enregistre un mouvement de la main. La température de couleur peut être contrôlée et les luminaires peuvent être réglés à l'aide d'un interrupteur mural ou d'un interrupteur à bascule.

FUNCTIONAL LIGHT

KÜCHE & MÖBEL

Kitchen & Furniture / Cuisine & mobilier





Die Küche bildet heutzutage den Mittelpunkt des Familienlebens. Die Beleuchtung muss vielen Ansprüchen gerecht werden. Warme und kalte Lichtfarben sorgen für die richtige Beleuchtung beim Kochen oder für ein gemütliches Ambiente beim gemeinsamen Abendessen.

Nowadays the kitchen is the centre of family life. The lighting must meet many demands. Warm and cold light colours provide the right lighting for cooking or for a cosy atmosphere during dinner.

Aujourd'hui, la cuisine est le centre de la vie familiale. L'éclairage doit répondre à de nombreuses demandes. Les couleurs chaudes et froides de la lumière fournissent un éclairage adéquat pour la cuisine ou pour une ambiance chaleureuse pour le dîner en commun.

FUNCTIONAL LIGHT

KÜCHE & MÖBEL

Kitchen & Furniture / Cuisine & mobilier

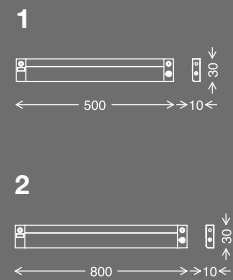
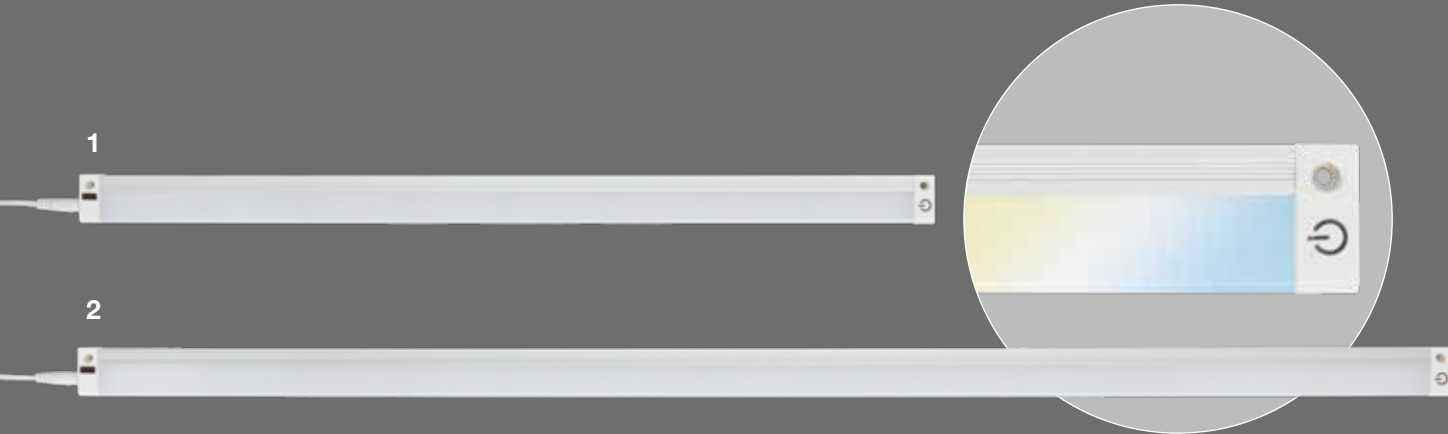

1. 202706TF EAN 4059709004648
Kunststoff-Metall weiß
Plastic-metal white | Plastique-métal blanc
Incl. 1x LED-Platine | 5,5W | 520lm
3.000/4.000/6.500K

2. 202806TF EAN 4059709004655
Kunststoff-Metall weiß
Plastic-metal white | Plastique-métal blanc
Incl. 1x LED-Platine | 7W | 720lm
3.000/4.000/6.500K



LIGHTS HADIT

3

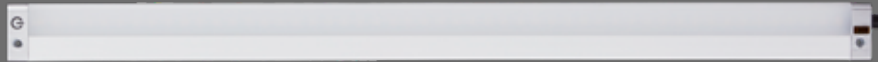

4

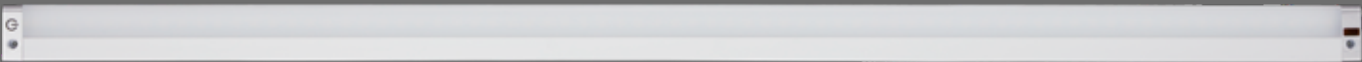

INDIRECT
LIGHT

1-4 HIGH-LIGHTS

- Mit Infrarot-Sensor
- Inkl. 1,5m Zuleitung
- Inkl. Montagematerial



Inkl. Infrarot-Sensor
Incl. infrared sensor
Incl. capteur infrarouge

- Incl. infrared sensor
 - Incl. Supply 1,5m
 - Incl. mounting material
-
- Incl. capteur infrarouge
 - Incl. alimentation 1,5m
 - Incl. matériel de montage

3



4



3. 202904TF EAN 4059709004662
Kunststoff-Metall silberfarbig
 Plastic-metal silver | Plastique-métal argenté
 Incl. 1x LED-Platine | 5,5W | 500lm (direct)
 Incl. 1x LED-Platine | 2,8W | 200lm (indirect)
 4.000K direct | 3.000K indirect

4. 203004TF EAN 4059709004679
Kunststoff-Metall silberfarbig
 Plastic-metal silver | Plastique-métal argenté
 Incl. 1x LED-Platine | 7W | 700lm (direct)
 Incl. 1x LED-Platine | 3,5W | 300lm (indirect)
 4.000K direct | 3.000K indirect

KÜCHE & MÖBEL

Kitchen & Furniture / Cuisine & mobilier

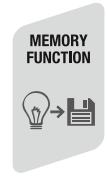

LIGHTS HADIT



Inkl. Infrarot-Sensor
Incl. infrared sensor
Incl. capteur infrarouge

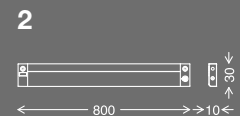
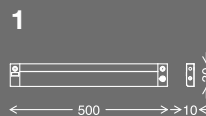

1. 203104TF EAN 4059709004686
Kunststoff-Metall silberfarbig
Plastic-metal silver | Plastique-métal argenté
Incl. 1x LED-Platine | 7W | 720lm
4.000K

2. 203204TF EAN 4059709004693
Kunststoff-Metall silberfarbig
Plastic-metal silver | Plastique-métal argenté
Incl. 1x LED-Platine | 9W | 1.000lm
4.000K



LIGHTS ZEUS



Inkl. Infrarot-Sensor
Incl. infrared sensor
Incl. capteur infrarouge

1-5 HIGH-LIGHTS

- Mit Infrarot-Sensor
- Inkl. 1,5m Zuleitung
- Inkl. Montagematerial

- Incl. infrared sensor
- Incl. Supply 1,5m
- Incl. mounting material

- Incl. capteur infrarouge
- Incl. alimentation 1,5m
- Incl. matériel de montage

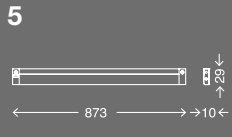
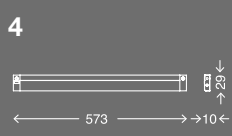
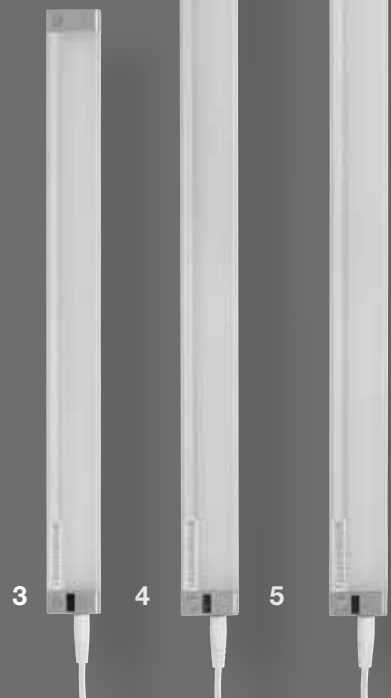

3. 201404TF EAN 4059709001722
Kunststoff-Metall silberfarbig
Plastic-metal silver | Plastique-métal argenté
Incl. 1x LED-Platine | 4W | 400lm
4.000K

4. 201504TF EAN 4059709001739
Kunststoff-Metall silberfarbig
Plastic-metal silver | Plastique-métal argenté
Incl. 1x LED-Platine | 8W | 800lm
4.000K

5. 201604TF EAN 4059709001746
Kunststoff-Metall silberfarbig
Plastic-metal silver | Plastique-métal argenté
Incl. 1x LED-Platine | 10W | 1.100lm
4.000K

FUNCTIONAL LIGHT

KÜCHE & MÖBEL

Kitchen & Furniture / Cuisine & mobilier

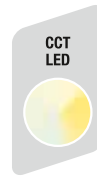

LIGHTS KRONOS

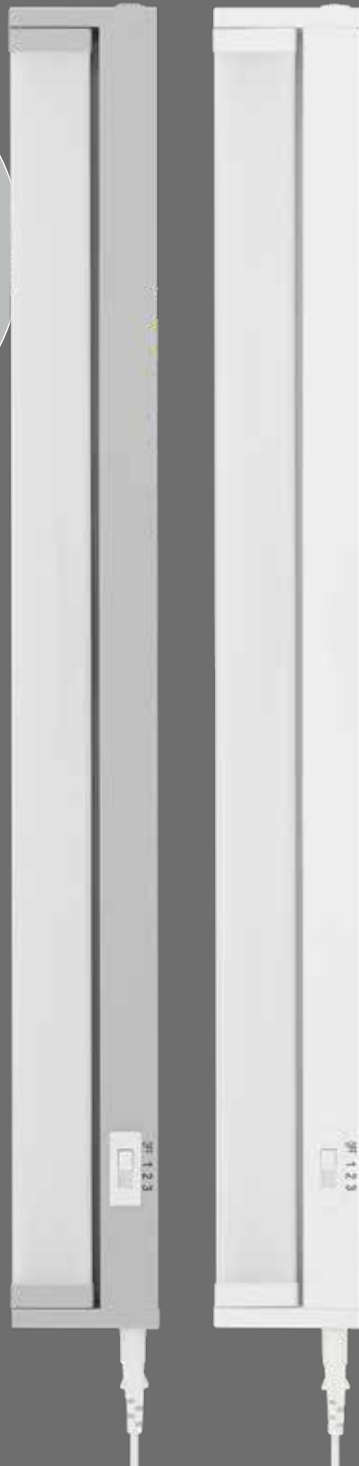

1+2

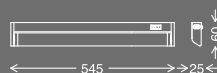

1 - 4 HIGH-LIGHTS

- 1+2 Inkl. Stufenschalter (OFF/CCT)
- 3+4 Inkl. Wippschalter (ON/OFF)
- Inkl. 1,8m Zuleitung
- Inkl. Verbindungskabel

- 1+2 Inkl. step switch (OFF/CCT)
- 3+4 Inkl. rocker switch (ON/OFF)
- Inkl. Supply 1,8m
- Inkl. connecting cable

- 1+2 Inkl. interrupteur à paliers (OFF/CCT)
- 3+4 Inkl. interrupteur à bascule (ON/OFF)
- Inkl. alimentation 1,8m
- Inkl. câble de connexion

1. 205104TF EAN 4059709004884

Kunststoff grau

Plastic gray | Plastique gris
Incl. 1x LED-Platine | 6,5W | 720lm
2.700/4000/6.500K

2. 205106TF EAN 4059709004891

Kunststoff weiß

Plastic white | Plastique blanc
Incl. 1x LED-Platine | 6,5W | 720lm
2.700/4000/6.500K



LIGHTS NUIT

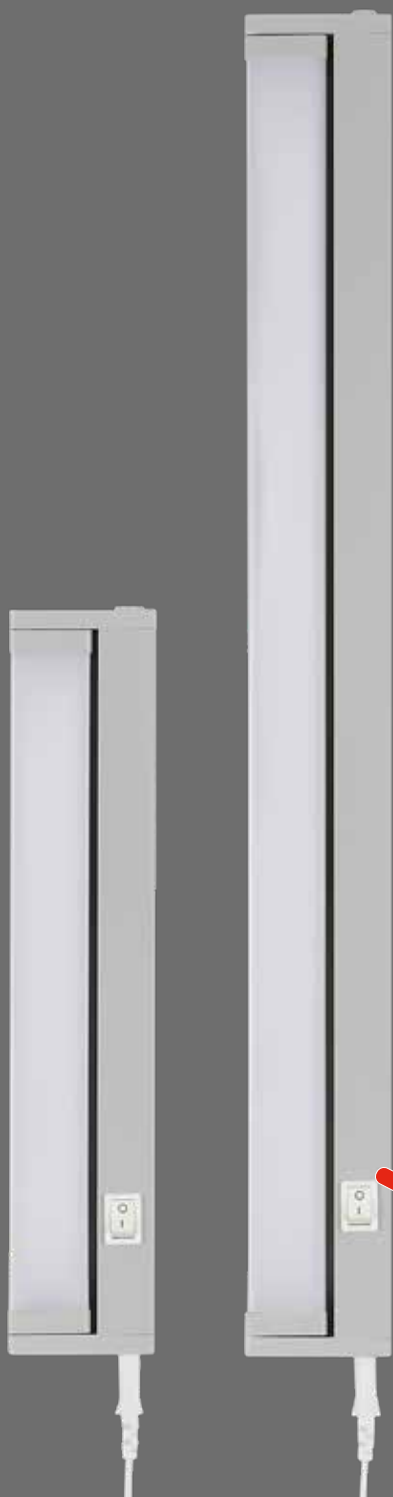

Schwenkbar
Rotatable
Orientable

3

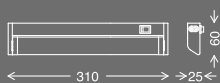

4.



3. 204204TF EAN 4059709004792

Kunststoff grau

Plastic gray | Plastique gris
Incl. 1x LED-Platine | 5,5W | 600lm
3.000K

4. 204304TF EAN 4059709004808

Kunststoff grau

Plastic gray | Plastique gris
Incl. 1x LED-Platine | 10W | 1.100lm
3.000K

FUNCTIONAL LIGHT

KÜCHE & MÖBEL

Kitchen & Furniture / Cuisine & mobilier





LIGHTS HESTIA



Schwenkbar
Rotatable
Orientable

1-2 HIGH-LIGHTS

- Verbindbar bis max. 10 Stück
- Schwenkbar
- Inkl. Wippschalter (ON/OFF)
- Connectable to max. 10 pieces
- Rotatable
- Incl. rocker switch (ON/OFF)
- Connectable jusqu'à 10 pcs
- Orientable
- Incl. interrupteur à bascule (ON/OFF)

1+2

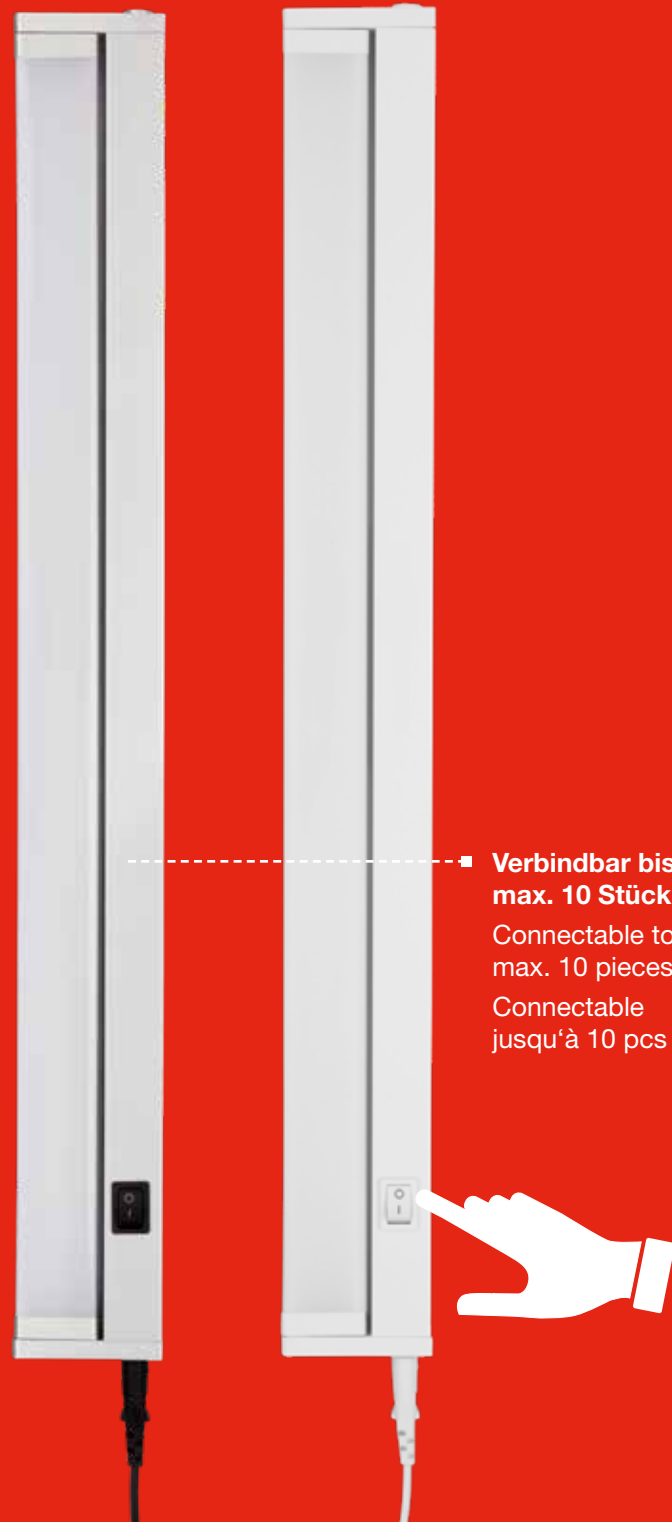

- **Verbindbar bis max. 10 Stück**
Connectable to max. 10 pieces
Connectable jusqu'à 10 pcs

1. 600104TF EAN 4059709000374

Kunststoff titanfarbig

Plastic titanium colour | Plastique couleur titane
Incl. 1x LED-Platine | 8,5W | 1.000lm
4.000K

2. 600106TF EAN 4059709000381

Kunststoff weiß

Plastic-metal white | Plastique-métal blanc
Incl. 1x LED-Platine | 8,5W | 1.000lm
4.000K

KÜCHE & MÖBEL

Kitchen & Furniture / Cuisine & mobilier

LIGHTS POSEIDON

Verbindbar bis max. 10 Stück
Connectable to max. 10 pieces
Connectable jusqu'à 10 pcs

Verbindbar bis max. 10 Stück
Connectable to max. 10 pieces
Connectable jusqu'à 10 pcs

LIGHTS RHEA

1 - 4 HIGH-LIGHTS

- LED-Unterbauleuchte
- Inkl. Wippschalter (ON/OFF)
- Inkl. Zuleitung 1,5m
- Inkl. Verbindungskabel 15cm
- LED under cabinet light
- Incl. rocker switch (ON/OFF)
- Incl. lead 1,5m
- Incl. connecting cable 15cm
- Réglette LED
- Incl. interrupteur à bascule (ON/OFF)
- Incl. alimentation 1,5m
- Incl. câble de connexion 15cm

1. 201106TF EAN 4059709001692

Kunststoff weiß

Plastic white | Plastique blanc
Incl. 1x LED-Platine | 4W | 400lm
3.000/4.000/6.500K

2. 201206TF EAN 4059709001708

Kunststoff weiß

Plastic white | Plastique blanc
Incl. 1x LED-Platine | 9W | 900lm
3.000/4.000/6.500K

3. 201306TF EAN 4059709001715

Kunststoff weiß

Plastic white | Plastique blanc
Incl. 1x LED-Platine | 13W | 1.300lm
3.000/4.000/6.500K

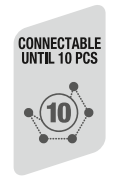
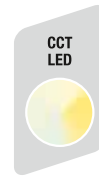

1

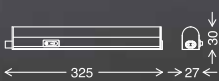

2

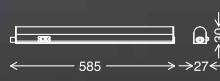

3

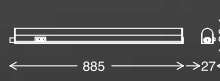

4

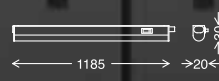

4. 204906TF EAN 4059709004860

Kunststoff weiß

Plastic white | Plastique blanc

Incl. 1x LED-Platine | 14W | 1.400lm

3.000/4.000/6.500K

FUNCTIONAL LIGHT

KÜCHE & MÖBEL

Kitchen & Furniture / Cuisine & mobilier

LIGHTS

HEPHAISTOS

1

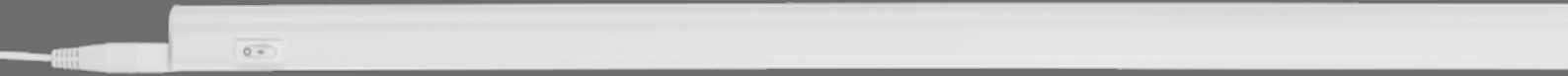

2



3

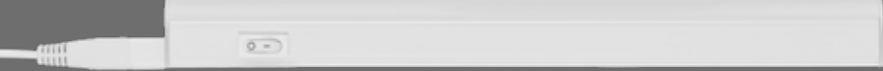

4

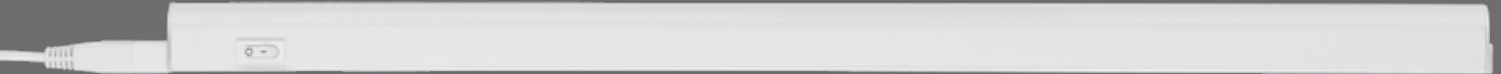

1

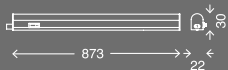

2

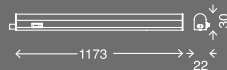

3

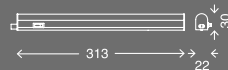

4

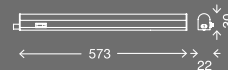

1. 200306TF EAN 4059709000336

Kunststoff weiß

Plastic white | Plastique blanc
Incl. 1x LED-Platine | 10W | 1.100lm
4.000K

2. 200406TF EAN 4059709000343

Kunststoff weiß

Plastic white | Plastique blanc
Incl. 1x LED-Platine | 14W | 1.400lm
4.000K



Verbindbar bis max. 10 Stück
Connectable to max. 10 pieces
Connectable jusqu'à 10 pcs

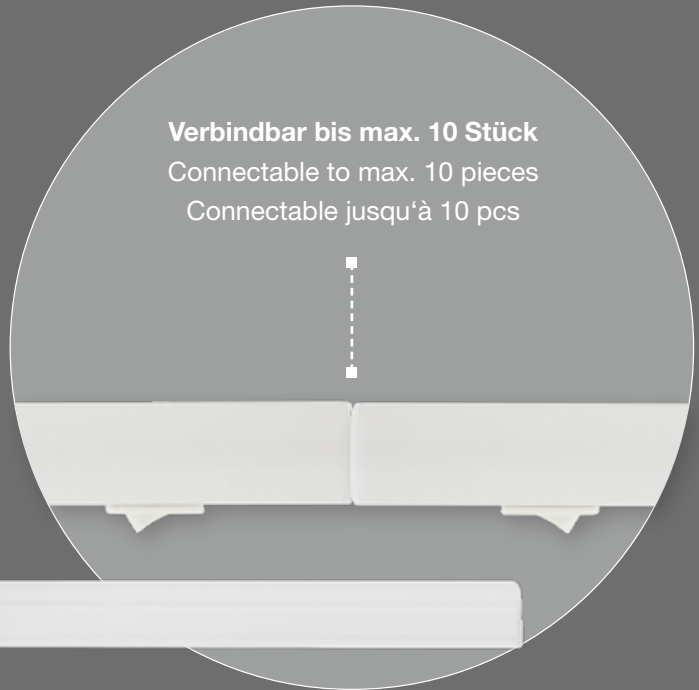

1-4 HIGH-LIGHTS

- Inkl. Wippschalter (ON/OFF)
- Inkl. Montagematerial
- Inkl. Zuleitung 1,5m
- Inkl. Verbindungskabel 15cm

- Incl. rocker switch (ON/OFF)
- Incl. assembly material
- Incl. Supply 1,5m
- Incl. connecting cable 15cm

- Incl. interrupteur à bascule (ON/OFF)
- Incl. matériel de montage
- Câble d'alimentation 1,5m incl.
- Incl. câble de connexion 15cm



3. 200106TF EAN 4059709000312

Kunststoff weiß

Plastic white | Plastique blanc
Incl. 1x LED-Platine | 4W | 400lm
4.000K

4. 200206TF EAN 4059709000329

Kunststoff weiß

Plastic white | Plastique blanc
Incl. 1x LED-Platine | 8W | 800lm
4.000K

KÜCHE & MÖBEL

Kitchen & Furniture / Cuisine & mobilier

LIGHTS
ANUBIS

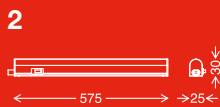

1. 204406TF EAN 4059709004815
Kunststoff weiß
Plastic white | Plastique blanc
Incl. 1x LED-Platine | 4,4W | 400lm
3.000K

2. 204506TF EAN 4059709004822
Kunststoff weiß
Plastic white | Plastique blanc
Incl. 1x LED-Platine | 8,3W | 750lm
3.000K

3. 204606TF EAN 4059709004839
Kunststoff weiß
Plastic white | Plastique blanc
Incl. 1x LED-Platine | 10,6W | 1.000lm
3.000K



LIGHTS SETH

1-3 HIGH-LIGHTS

- Inkl. Wippschalter (ON/OFF)
- Inkl. Montagematerial
- Inkl. Zuleitung 1m
- Inkl. Verbindungskabel 10cm

- Incl. rocker switch (ON/OFF)
- Incl. assembly material
- Incl. Supply 1m
- Incl. connecting cable 10cm

- Incl. interrupteur à bascule (ON/OFF)
- Incl. matériel de montage
- Câble d'alimentation 1m incl.
- Incl. câble de connexion 10cm



4



5



4. 204006TF EAN 4059709004778

Kunststoff-Metall weiß

Plastic-metal white | Plastique-métal blanc
Incl. 1x LED-Platine | 6W | 550lm
3.000K

5. 204106TF EAN 4059709004785

Kunststoff-Metall weiß

Plastic-metal white | Plastique-métal blanc
Incl. 1x LED-Platine | 8,5W | 850lm
3.000K

FUNCTIONAL LIGHT

KÜCHE & MÖBEL

Kitchen & Furniture / Cuisine & mobilier

LIGHTS
UTO





1-3 HIGH-LIGHTS

- Inkl. Wippschalter (ON/OFF)
- Inkl. Montagematerial
- Inkl. Zuleitung 1,6m
- Inkl. rocker switch (ON/OFF)
- Inkl. assembly material
- Inkl. Supply 1,6m
- Inkl. interrupteur à bascule (ON/OFF)
- Inkl. matériel de montage
- Câble d'alimentation 1,6m incl.

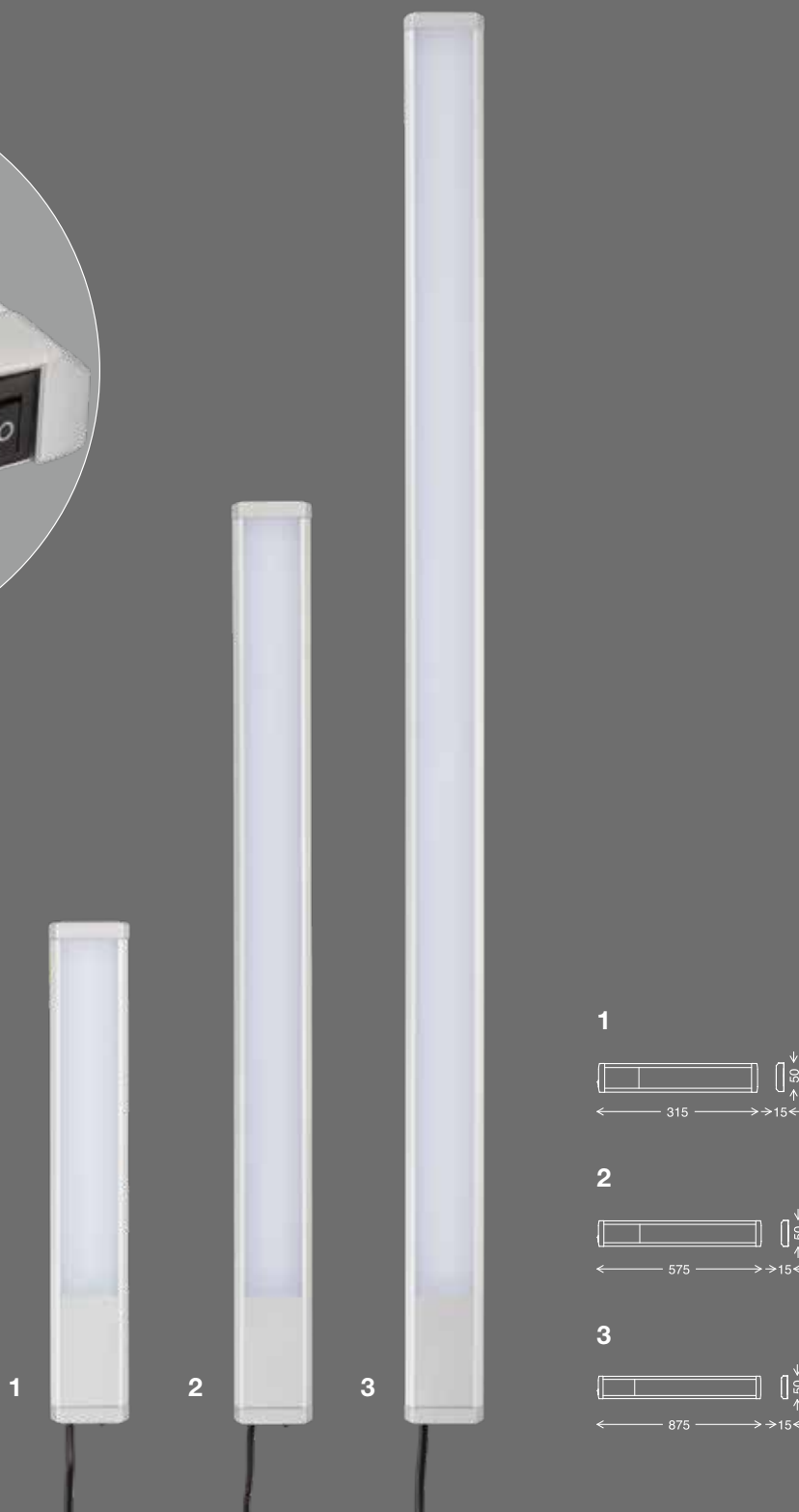

1. 203704TF EAN 4059709004747
Kunststoff-Metall silberfarbig
 Plastic-metal silver | Plastique-métal argenté
 Incl. 1x LED-Platine | 4W | 460lm
 4.000K

2. 203804TF EAN 4059709004754
Kunststoff-Metall silberfarbig
 Plastic-metal silver | Plastique-métal argenté
 Incl. 1x LED-Platine | 10W | 1.100lm
 4.000K

3. 203904TF EAN 4059709004761
Kunststoff-Metall silberfarbig
 Plastic-metal silver | Plastique-métal argenté
 Incl. 1x LED-Platine | 14W | 1.600lm
 4.000K

KÜCHE & MÖBEL

Kitchen & Furniture / Cuisine & mobilier



2

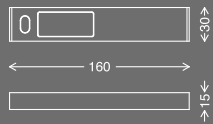

LIGHTS
THOT

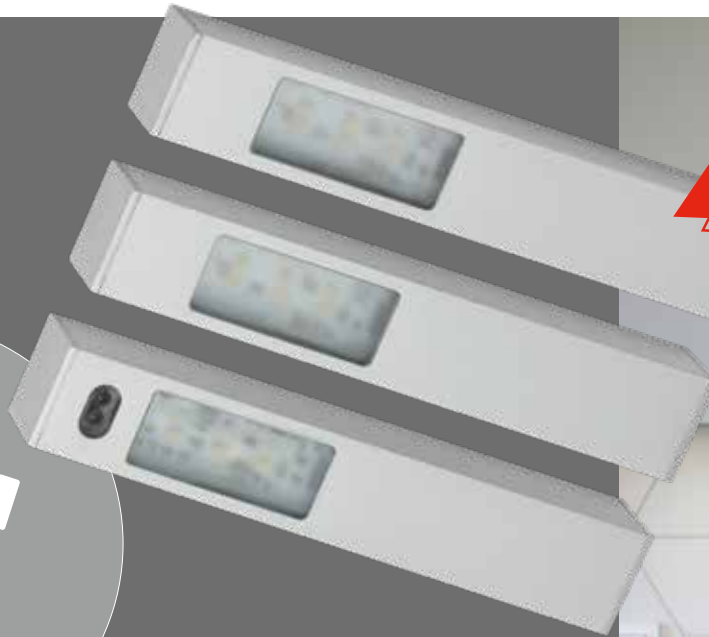

Inkl. Infrarot-Sensor
Incl. infrared sensor
Incl. interrupteur infrarouge

LIGHTS
SCHU



1

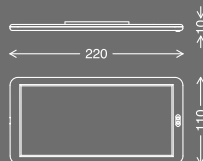

1-2 HIGH-
LIGHTS

- Mit Infrarot-Sensor
- Inkl. Montagematerial
- Inkl. Zuleitung 1,65m
- Inkl. infrared sensor
- Inkl. assembly material
- Inkl. Supply 1,65m
- Inkl. capteur infrarouge
- Inkl. matériel de montage
- Câble d'alimentation 1,65m incl.

1. 203506TF EAN 4059709004723

Kunststoff-Metall weiß

Plastic-metal white | Plastique-métal blanc
Incl. 1x LED-Platine | 6,5W | 400lm
4.000K

2. 203609TF EAN 4059709004730

Kunststoff-Metall aluminiumfarbig

Plastic-metal aluminium coloured |
Plastique-métal couleur alu
Incl. 3x LED-Platine | 2,5W | 180lm
4.000K



LIGHTS
DIONYSOS



3

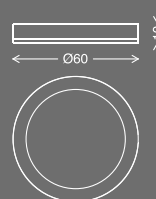

3. 205009TF EAN 4059709004877

Kunststoff aluminiumfarbig

Plastic-metal aluminium coloured |

Plastique-métal couleur alu

Incl. 3x LED-Platine | 1,8W | 170lm

3.000K

KÜCHE & MÖBEL

Kitchen & Furniture / Cuisine & mobilier

LIGHTS
HADES

1

2



1+2



1-2 HIGH-LIGHTS

- Inkl. zwei Steckdosen
- Mit Direktanschluß
- Inkl. Wippschalter (ON/OFF)

- Incl. two sockets
- With directly connectable
- Incl. rocker switch (ON/OFF)

- Incl. deux prises
- Avec connexion directe
- Incl. interrupteur à bascule (ON/OFF)

1. 200704TF EAN 4059709000299

Kunststoff titanfarbig | Plastic titanium colour | Plastique couleur titane
Incl. 1x LED-Platine | 10W | 850lm
4.000K

2. 200706TF EAN 4059709000305

Kunststoff weiß
Plastic white | Plastique blanc
Incl. 1x LED-Platine | 10W | 850lm
4.000K



LIGHTS
ARES

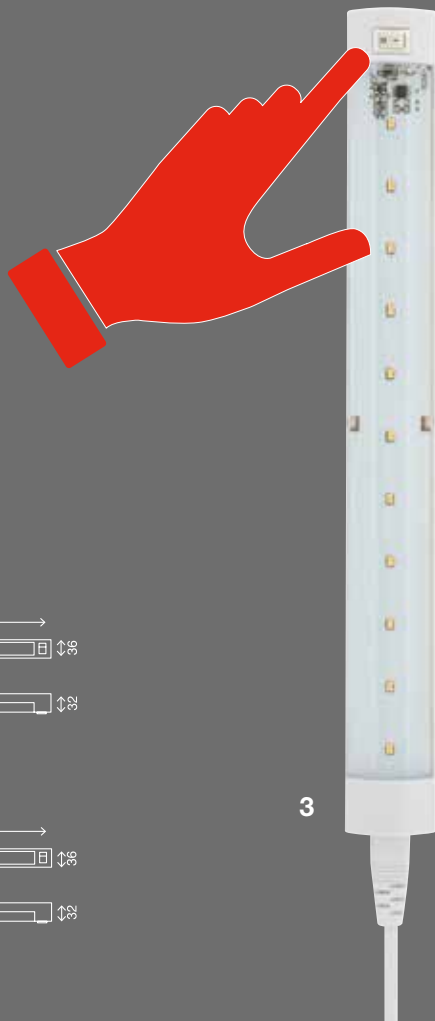

3-4 HIGH-LIGHTS

- Inkl. Wippschalter (ON/OFF)
- Inkl. Zuleitung steckbar

- Incl. rocker switch (ON/OFF)
- Incl. supply cable plugable

- Incl. interrupteur à bascule (ON/OFF)
- Incl. câble d'alimentation à prise

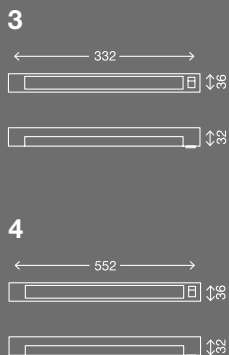

3. 600606TF EAN 4059709000428

Kunststoff weiß

Plastic white | Plastique blanc
Incl. 1x LED-Platine | 4,2W | 350lm
4.000K

4. 600706TF EAN 4059709000435

Kunststoff weiß

Plastic white | Plastique blanc
Incl. 1x LED-Platine | 8,5W | 650lm
4.000K

KÜCHE & MÖBEL

Kitchen & Furniture / Cuisine & mobilier

LIGHTS HERA

Stufenlos dimmbar
Infinitely dimmable
Dimmable en continu

ON/OFF Schalter
ON/OFF Switch
interrupteur ON/OFF

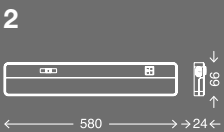
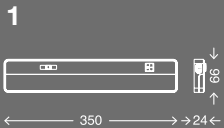
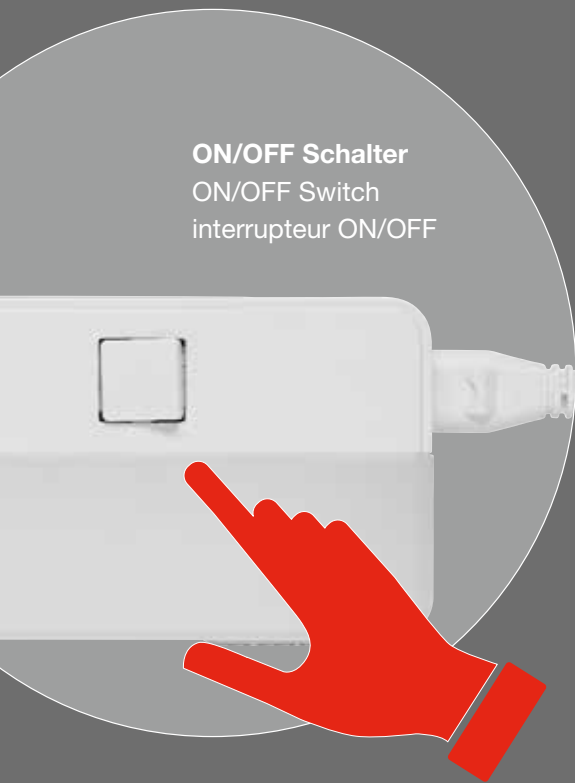

1-2 HIGH-LIGHTS

- Mit Wippschalter (ON/OFF)
- Inkl. 1,5m Zuleitung
- Stufenlos dimmbar
- Rocker switch (ON/OFF)
- Incl. Supply 1,5m
- Infinitely dimmable
- Incl. interrupteur à bascule (ON/OFF)
- Câble d'alimentation 1,5m incl.
- Dimmable en continu

1. 202006TF EAN 4059709001784

Kunststoff weiß

Plastic white | Plastique blanc
Incl. 1x LED-Platine | 5,5W | 400lm
4.000K

2. 202106TF EAN 4059709001791

Kunststoff weiß

Plastic white | Plastique blanc
Incl. 1x LED-Platine | 8,5W | 700lm
4.000K

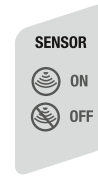

LIGHTS
APOLLON



3-4 HIGH-LIGHTS

- Inkl. Bewegungsmelder mit Microwave Sensor
- Reichweite max. 8m
- Zeiteinstellung 5sek.- 10min.
- Inkl. Dauerlichtfunktion
- Dämmerungssensor aus oder <25lux
- Inkl. motion detector with microwave sensor
- Range max. 8m
- Time setting 5sec.- 10min.
- Incl. continuous light function
- Twilight sensor off or <25lux
- Détecteur de mouvement incl.
- Portée max. 8m
- Réglage du temps 5sec.- 10min.
- Avec fonction d'éclairage permanent
- Capteur crépusculaire éteint ou <25lux

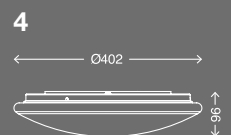
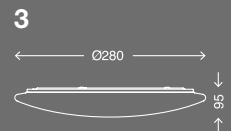

3. 601206TF EAN 4059709001807
Kunststoff-Metall weiß
Plastic-metal white | Plastique-métal blanc
Incl. 1x LED-Platine | 15W | 1.500lm
4.000K

4. 601306TF EAN 4059709001814
Kunststoff-Metall weiß
Plastic-metal white | Plastique-métal blanc
Incl. 1x LED-Platine | 20W | 2.000lm
4.000K

FUNCTIONAL LIGHT

WOHNEN & BÜRO

Home & Office / Maison & Bureau





Wohnräume sind nicht mehr klassisch voneinander getrennt. Ein Büro braucht längst nicht mehr nur kühles, helles Licht, während ein Wohnzimmer längst nicht mehr mit gleichbleibend warmem Licht auskommt. Offene Räume erfordern einzelne Lichtpunkte, die je nach Bedarf zu einem großen Ganzen zusammenschaltet werden können, aber eben auch allein funktionieren.

Living spaces aren't separated from one another like they used to be. It's no longer the case that an office just needs cool, bright light or that a living room just needs warm light all day long. Open-plan spaces require individual light sources that can be interconnected to form a larger whole as desired but can also work independently.

Nous avons révisé les séparations classiques de nos espaces de vie. Un bureau n'a plus besoin d'une lumière froide et vive, tandis qu'un salon ne sous-entend plus forcément une lumière chaude constante. Les espaces ouverts requièrent des sources lumineuses séparées, qui peuvent être regroupées en un large ensemble au besoin et conserver leurs propres spécificités.

FUNCTIONAL LIGHT

WOHNEN & BÜRO

Home & Office / Maison & Bureau

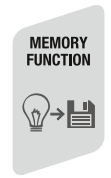
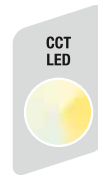

LIGHTS BASTET

1



2



1



2

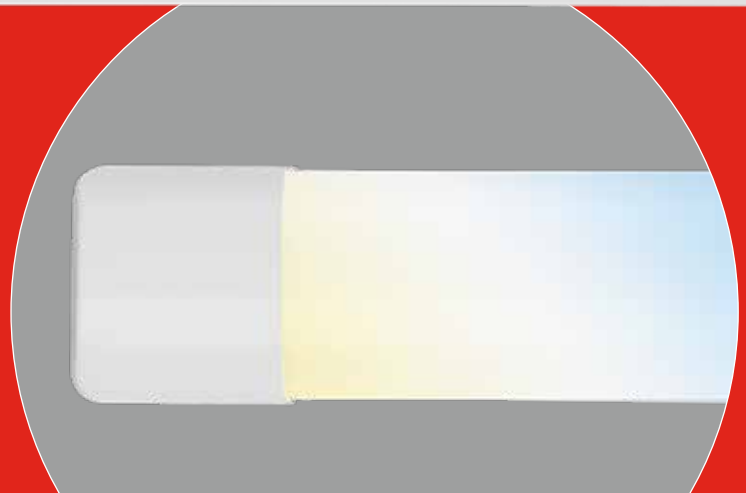

1-2 HIGH-LIGHTS

- Lichtfarbe in Stufen wechselbar
- Memory-Funktion
- Unaufdringliches Design
- Light colour changeable in steps
- Memory function
- Discreet design
- Couleur de la lumière réglable par paliers
- Fonction mémoire
- Design discret



1. 202506TF EAN 4059709004624

Kunststoff weiß

Plastic white | Plastique blanc
Incl. 1x LED-Platine | 18W | 2.100lm
4.000/6.500K

2. 202606TF EAN 4059709004631

Kunststoff weiß

Plastic white | Plastique blanc
Incl. 1x LED-Platine | 33W | 3.650lm
4.000/6.500K

LIGHTS
POEL

3

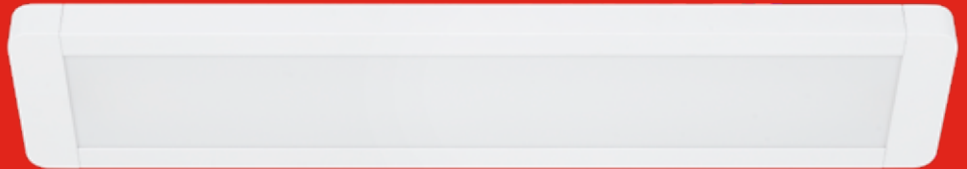

4

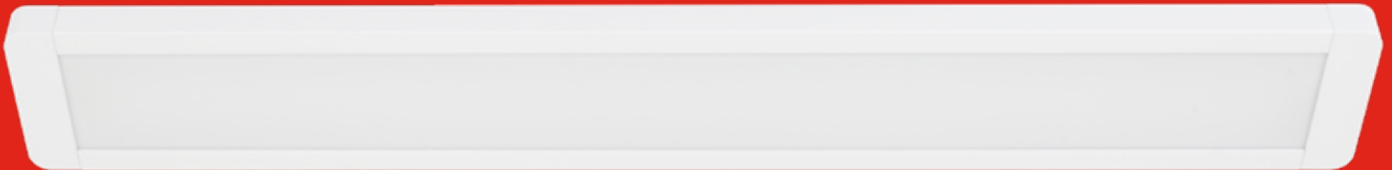

3



4



3. 205506TF EAN 4059709004945
Kunststoff-Metall weiß
Plastic-metal white | Plastique-métal blanc
Incl. 1x LED-Platine | 25W | 2.900lm
4.000K

4. 205606TF EAN 4059709004952
Kunststoff-Metall weiß
Plastic-metal white | Plastique-métal blanc
Incl. 1x LED-Platine | 37W | 4.400lm
4.000K

FUNCTIONAL LIGHT

WOHNEN & BÜRO

Home & Office / Maison & Bureau

LIGHTS
KISTA





1-2 HIGH-LIGHTS

- Homogene Lichtfläche
- Außergewöhnlich hohe Leuchtkraft
- puristisches Design

- Homogenous light surface
- Exceptionally high luminosity
- Puristic design

- Surface lumineuse par paliers
- Luminosité exceptionnelle
- Design puriste

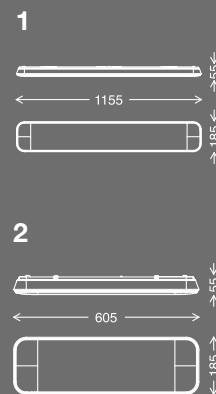

1. 205406TF EAN 4059709004938
Kunststoff-Metall weiß
Plastic-metal white | Plastique-métal blanc
Incl. 1x LED-Platine | 49W | 5.300lm
4.000K

2. 205306TF EAN 4059709004921
Kunststoff-Metall weiß
Plastic-metal white | Plastique-métal blanc
Incl. 1x LED-Platine | 24W | 2.800lm
4.000K

FUNCTIONAL LIGHT

WERKSTATT, KELLER & GARAGE

Workshop, Cellar & Garage / Atelier, Cave & Garage





Die dunklen Ecken in Garage und Keller, oder die unbeleuchteten Zugänge zu diesen; wer kennt die daraus resultierenden Alltagsprobleme nicht? Auch dazu haben wir uns Gedanken gemacht, als wir unser Functional Light Sortiment erweitert haben. Ab sofort finden Sie Lösungen für all die Bereiche in Ihrem Zuhause, die Sie im ersten Moment nicht bedacht haben, über welche sie aber immer wieder „stolpern“.

Dark corners and unlit areas in the garage or the cellar; everyone knows the problems they can cause in everyday life. That's something we gave careful thought to when we expanded our Functional Light Assortment. Now, you can find solutions for all those areas in your home, that you didn't give much previous thought to, but you keep "stumbling" over.

Qui n'a jamais rencontré des problèmes dans son quotidien à cause d'un garage, d'une cave ou de leurs accès non-éclairés ? Nous avons pris en compte ces problèmes en élargissant notre gamme Functional Light. Vous trouverez désormais des solutions pour tous les recoins de la maison auxquels vous n'aviez même pas encore pensé. Cela changera votre quotidien !

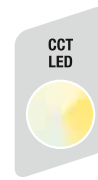

LIGHTS
CHONS

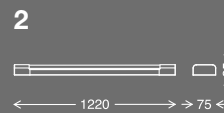
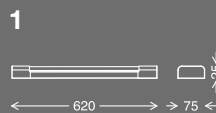
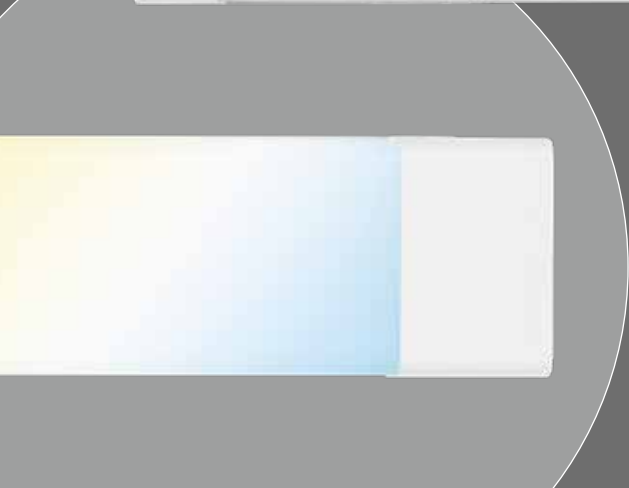

1-2 HIGH-LIGHTS

- Homogene Lichtfläche
- Außergewöhnlich hohe Leuchtkraft
- puristisches Design

- Homogenous light surface
- Exceptionally high luminosity
- Puristic design

- Surface lumineuse par palliers
- Luminosité exceptionnelle
- Design puriste

1. 203306TF EAN 4059709004709
Kunststoff-Metall weiß
 Plastic-metal white | Plastique-métal blanc
 Incl. 1x LED-Platine | 22W | 2.600lm
 4.000/6.500K

2. 203406TF EAN 4059709004716
Kunststoff-Metall weiß
 Plastic-metal white | Plastique-métal blanc
 Incl. 1x LED-Platine | 45W | 5.000lm
 4.000/6.500K

LIGHTS
MAAT

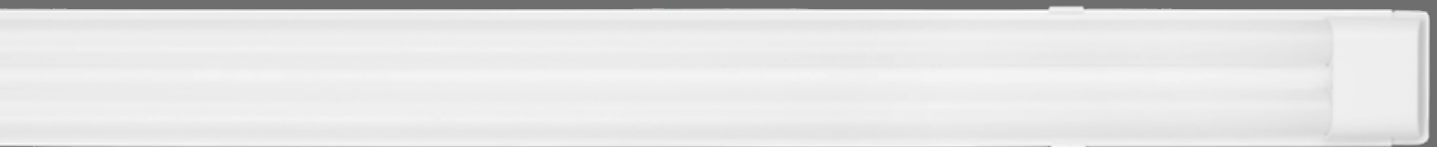
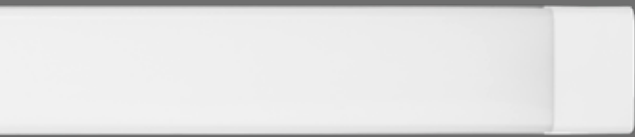

4

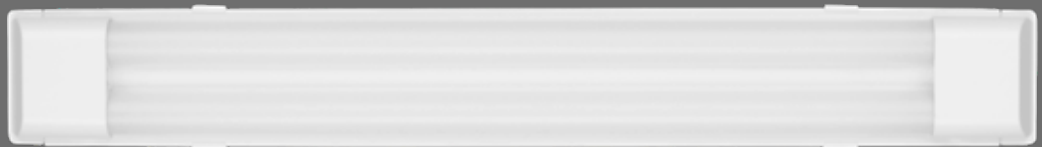

3

3-4 HIGH-LIGHTS

- Inkl. Montagematerial
- außergewöhnlich hohe Leuchtkraft
- Incl. mounting material
- Exceptionally high luminosity
- Y compris matériel de montage
- Luminosité exceptionnelle

3



4

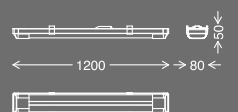

3. 204706TF EAN 4059709004846

Kunststoff weiß

Plastic white | Plastique blanc

Incl. 1x LED-Platine | 24W | 2.700lm

4.000K

4. 204806TF EAN 4059709004853

Kunststoff weiß

Plastic white | Plastique blanc

Incl. 1x LED-Platine | 50W | 5.500lm

4.000K

WERKSTATT, KELLER & GARAGE

Workshop, Cellar & Garage / Atelier, Cave & Garage

HQ
LED
25.000h

LIGHTS
HEBE



1-2 HIGH-LIGHTS

- Mit Direktanschluß
- Inkl. Montagematerial
- With directly connectable
- Incl. assembly material
- Avec connexion directe
- Incl. matériel de montage

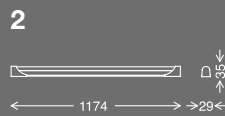
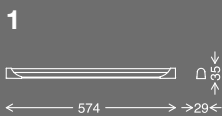

1. 200506TF EAN 4059709000442

Kunststoff weiß

Plastic white | Plastique blanc
Incl. 1x LED-Platine | 8W | 800lm
4.000K

2. 200606TF EAN 4059709000350

Kunststoff weiß

Plastic white | Plastique blanc
Incl. 1x LED-Platine | 14W | 1.400lm
4.000K

LIGHTS
ARTEMIS

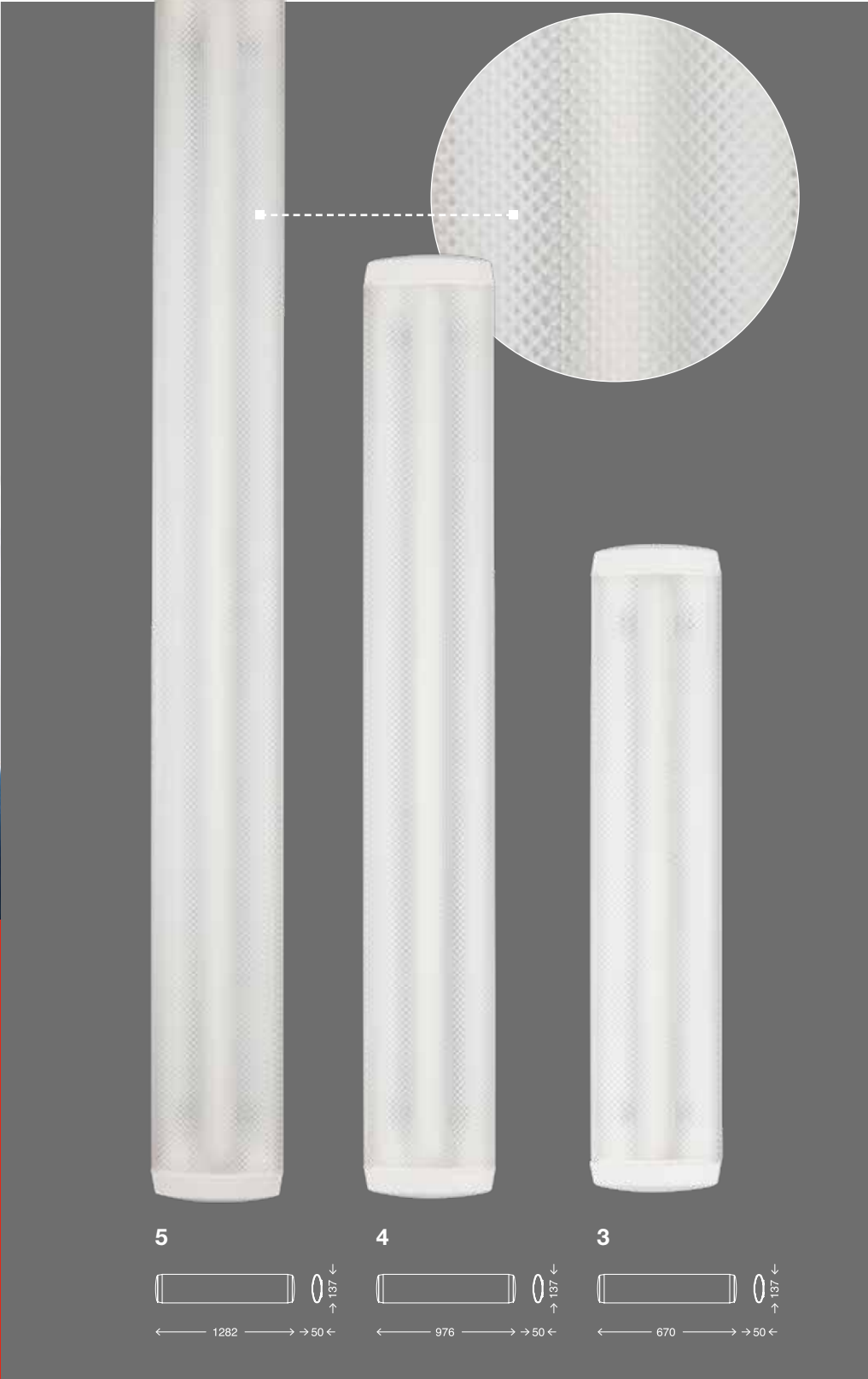

3-5 HIGHLIGHTS

- LED-Deckenleuchte
- Mit Prismenoptik
- LED ceiling light
- With prism optics
- Plafonnier LED
- Avec optique à prismes

3. 202206TF EAN 4059709001821
Kunststoff weiß
 Plastic white | Plastique blanc
 Incl. 1x LED-Platine | 13W | 1.600lm
 5.000K

4. 202306TF EAN 4059709001838
Kunststoff weiß
 Plastic white | Plastique blanc
 Incl. 1x LED-Platine | 23W | 3.000lm
 5.000K

5. 202406TF EAN 4059709001845
Kunststoff weiß
 Plastic white | Plastique blanc
 Incl. 1x LED-Platine | 30W | 3.680lm
 5.000K



LIGHTS
ATHENE

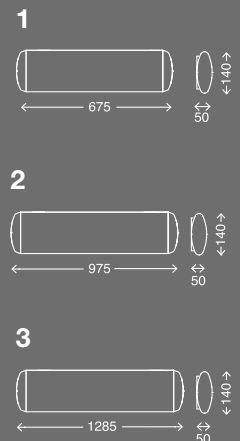

1 - 3 HIGH-LIGHTS

- LED-Deckenleuchte
1-flammig
- LED ceiling light
1-flame
- Plafonnier LED
1-flamme

1. 600406TF EAN 4059709000398
Kunststoff-Metall weiß
 Plastic-metal white | Plastique-métal blanc
 Incl. 1x LED-Platine | 10W | 1.200lm
 4.000K

2. 600306TF EAN 4059709000404
Kunststoff-Metall weiß
 Plastic-metal white | Plastique-métal blanc
 Incl. 1x LED-Platine | 20W | 2.400lm
 4.000K

3. 600506TF EAN 4059709000411
Kunststoff-Metall weiß
 Plastic-metal white | Plastique-métal blanc
 Incl. 1x LED-Platine | 23W | 2.600lm
 4.000K

LIGHTS DEMETA



4-6 HIGH- LIGHTS

- LED-Deckenleuchte
- In Stufen dimmbar über Lichtschalter
- LED ceiling light
- In steps dimmable via light switch
- Plafonnier LED
- Dimmable par palier grâce à un interrupteur



4. 201706TF EAN 4059709001753

Kunststoff weiß

Plastic white | Plastique blanc

Incl. 1x LED-Platine | 13W | 1.600lm
5.000K

5. 201806TF EAN 4059709001760

Kunststoff weiß

Plastic white | Plastique blanc

Incl. 1x LED-Platine | 23W | 3.000lm
5.000K

6. 201906TF EAN 4059709001777

Kunststoff weiß

Plastic white | Plastique blanc

Incl. 1x LED-Platine | 23W | 3.300lm
5.000K

FUNCTIONAL LIGHT

WERKSTATT, KELLER & GARAGE

Workshop, Cellar & Garage / Atelier, Cave & Garage



LIGHTS
LANKA

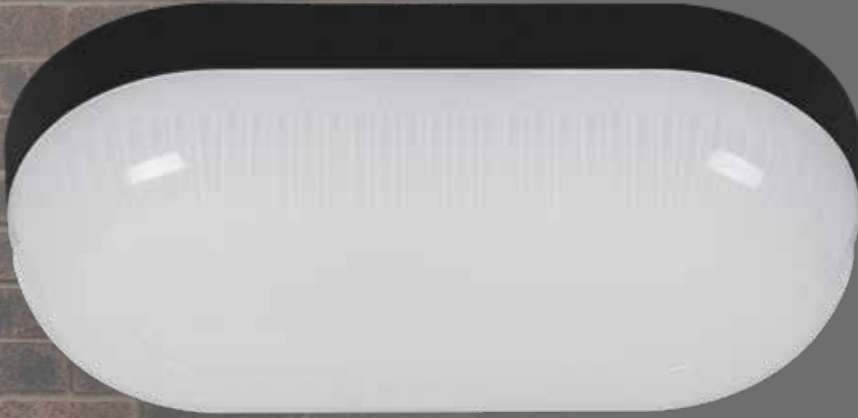

1

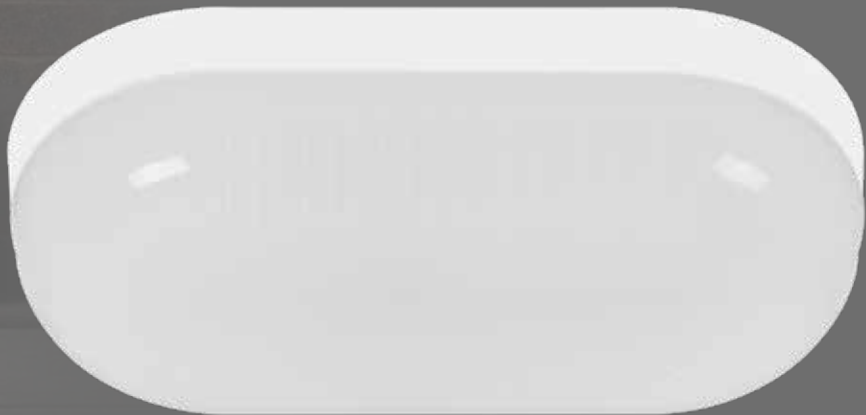

2

1-2 HIGH-LIGHTS

- LED-Deckenleuchte
- HQ-LED mit 25.000 h Lebensdauer

- LED ceiling light
- HQ-LED with 25.000 h lifetime

- Plafonnier LED
- LED HQ avec une durée de vie de 25 000 h

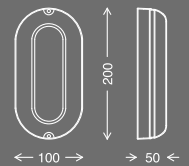

1. 205205TF EAN 4059709004907
Kunststoff schwarz
Plastic black | Plastique noir
Incl. 1x LED-Platine | 15W | 1.500lm
4.000K

2. 205206TF EAN 4059709004914
Kunststoff weiß
Plastic white | Plastique blanc
Incl. 1x LED-Platine | 15W | 1.500lm
4.000K



Unsere Mikrowellen-Sensoren erkennen jegliche Bewegungen im Raum und schalten das Licht nach Ihrem Bedarf ein. Das spart Strom und ist im höchsten Maß komfortabel. Der Sensor ist unsichtbar hinter der Leuchtenabdeckung verbaut.

Our microwave sensors detect any movement in the room and switch the light on as required. This saves electricity and is extremely convenient. The sensor is invisibly installed behind the lamp cover.

Nos capteurs de mouvements par micro-ondes détectent tout mouvement dans la pièce et allument la lumière selon les besoins. Cela permet d'économiser de l'électricité et est extrêmement pratique. Le capteur est installé de manière invisible derrière le couvercle lumineux.

INTELLIGENTES LICHTMANAGEMENT FÜR MEHR FREIHEIT.

Intelligent lighting management for greater freedom.

Une gestion intelligente de la lumière pour plus de liberté.

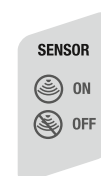

Override-Funktion
Override function
Fonction Override

Mit der Override-Funktion können Sie, über den Wandschalter, den Bewegungsmelder manuell aus und wieder anschalten.

With the override function, you can manually switch the motion detector off and on again using the wall switch.

Grâce à la fonction Override, vous pouvez allumer et éteindre manuellement le détecteur de mouvement en passant par l'interrupteur mural.

POINT OF SALE

Kennen Sie schon unsere individuellen Power-Displays?

Do you already know our individual power displays?
Connaissez-vous déjà nos présentations personnalisées à fort impact ?

UNSER BEITRAG FÜR
EINE GRÜNERE ZUKUNFT.
KARTON STATT BLISTER!



Our contribution to a greener future: Cardboard instead of blister! / Notre contribution à un avenir plus vert: du carton au lieu d'un blister.

TELEFUNKEN SENSORIK



TELEFUNKEN

RECHNUNGSLICHT MIT MICROWAVE-SENSORIK

- Reichweite bis zu 8 m
- Dämmerungssensor
- Time-Setting (5 sek. - 10 min.)
- Overridefunktion
- Auch aktiv bei Dämmerung (Sensor ist Morgenlicht)

TELEFUNKEN

ZUVERLÄSSIGES LICHT,
GANZ OHNE SCHALTER



NIE WAP LICHT INS DUNKLE
BRINGEN EINFACHER:

- Hochwertiger Microwaveensor
- Time-Setting (5 sek. - 10 min.)
- Reichweite bis zu 8 Metern
- Dämmerungssensor
- Overridefunktion
- Homogene Lichtverteilung
- Hohe Energieersparnis



Sensor bei Tageslicht AUS

Sensor OFF in daylight
Capteur ÉTEINT en plein jour

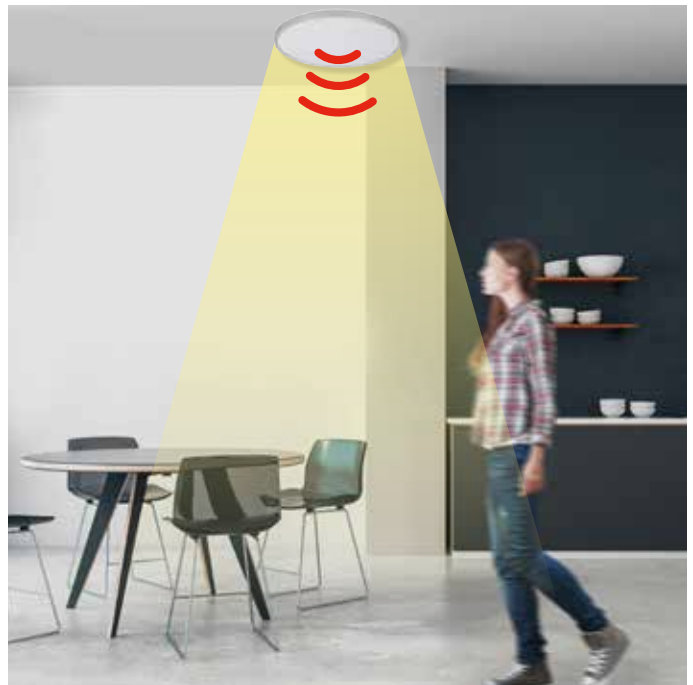

Sensor bei Dunkelheit AN

Sensor ON in darkness
Capteur ALLUMÉ dans l'obscurité

MODERNES LICHT PASST SICH IHREN GEWOHNHEITEN AN.

Modern light adapts to your habits.

La lumière moderne s'adapte à vos habitudes.

Modernes Licht hat viele Funktionen und passt sich Ihren Lebensgewohnheiten problemlos an.

Das Licht schaltet sich bei registrierter Bewegung ein und ebenso wieder ab, sobald keine neue Bewegung erfasst wird.

In unserem Sensor Leuchtensortiment finden Sie für jeden Raum und jede Wohnsituation die passende Leuchte. Alle Leuchten verfügen über Hochfrequenz-Mikrowellensensoren. In einem Umkreis von mehreren Metern wird so jede Bewegung komfortabel erfasst.

Die Einschaltzeiten können individuell eingestellt werden. Bis zu 10 Minuten ist der überwachte Bereich dann ausgeleuchtet. Das bedeutet mehr Sicherheit. Auch, wenn niemand zuhause ist.

Modern light has many functions and adapts easily to your lifestyle.

The light switches on when movement is detected and switches off again when no new movement is detected.

In our sensor light range you will find the right light for every room and every living situation. Each of them has a high-frequency microwave sensor. Every movement within a radius of several meters is thus conveniently recorded.

The switch-on times can be set individually. The monitored area is then illuminated for up to 10 minutes. This means greater security. Even if nobody's home.

La lumière moderne a de nombreuses fonctions et s'adapte facilement à votre mode de vie.

La lumière s'allume lorsqu'un mouvement est détecté et s'éteint à nouveau si aucun nouveau mouvement n'est détecté.

Dans notre gamme Sensor Light, vous trouverez la lumière adaptée à chaque pièce et à chaque situation de vie. Chacun d'entre eux possède un capteur par micro-ondes à haute fréquence. Chaque mouvement dans un rayon de plusieurs mètres est ainsi facilement détecté.

Les heures de mise en marche peuvent être réglées individuellement. La zone surveillée est alors éclairée pendant 10 minutes. Cela signifie plus de sécurité. Même si personne n'est à la maison.

LICHT AN BEI BEWEGUNG

Light on while moving / Éclairage par mouvement



LIGHTS
REWNA

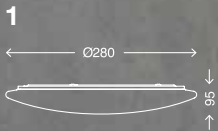

1. 602006TF EAN 4059709002460

Kunststoff-Metall weiß

Plastic-metal white | Plastique-métal blanc

Incl. 1x LED-Platine | 15W | 1.500lm

4.000K

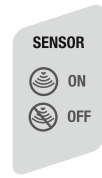
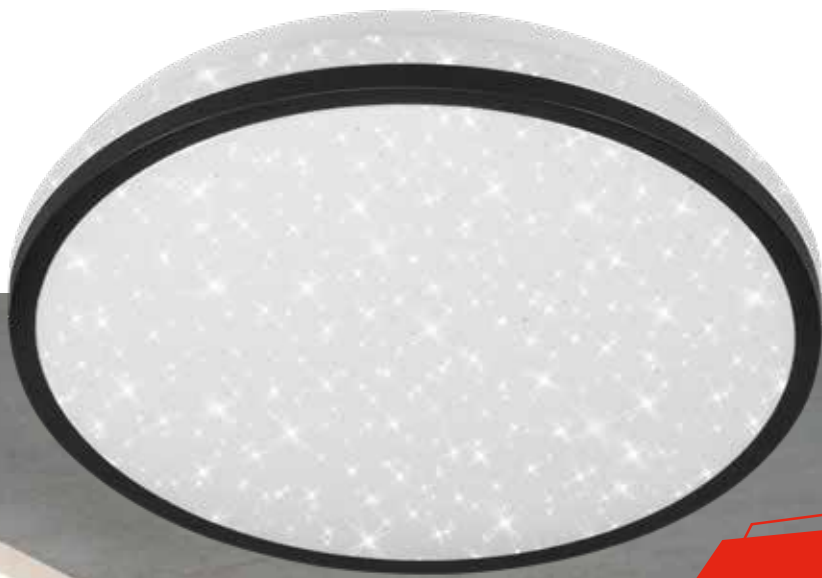

LIGHTS TEPI

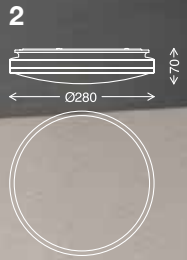

1-2 HIGH-LIGHTS

- Inkl. Bewegungsmelder mit Microwave Sensor
- Reichweite max. 8m
- Zeiteinstellung 5sek., 1min., 3min., 10min.
- Inkl. Dauerlichtfunktion
- Dämmerungssensor aus oder <25lux

- Incl. motion detector with microwave sensor
- Range max. 8m
- Time setting 5sec., 1min., 3min., 10min.
- Incl. continuous light function
- Twilight sensor off or <25lux

- Détecteur de mouvement incl.
- Portée max. 8m
- Réglage du temps 5sec., 1min., 3min., 10min.
- Avec fonction d'éclairage permanent
- Capteur crépusculaire éteint ou <25lux

2. 318305TF EAN 4059709004365

Kunststoff schwarz

Plastic black | Plastique noir

Incl. 1x LED-Platine | 16W | 1.500lm

4.000K

LICHT AN BEI BEWEGUNG

Light on while moving / Éclairage par mouvement

LIGHTS
FRAME

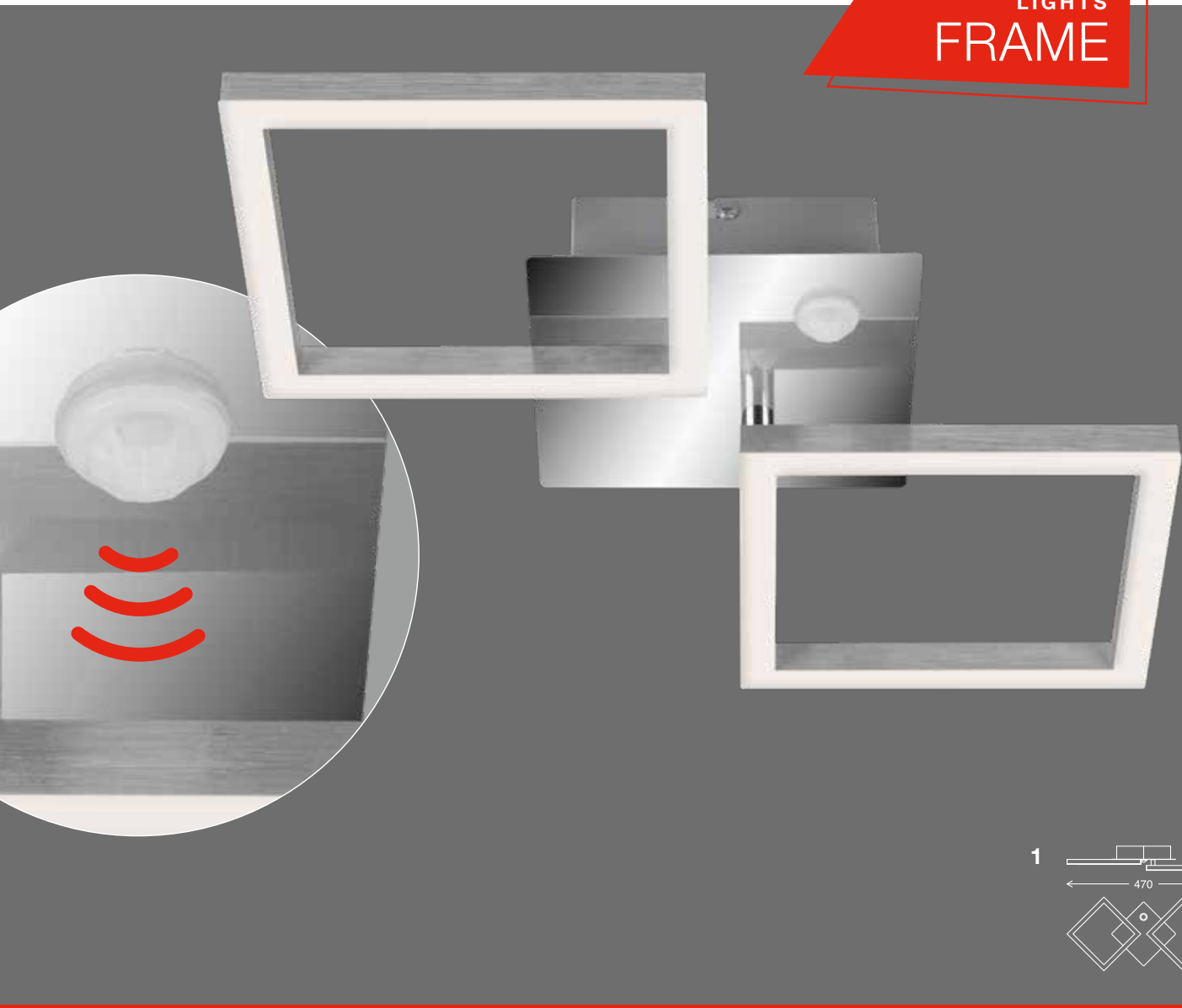

1-2 HIGH-LIGHTS

- Inkl. Bewegungsmelder mit Microwave Sensor
- Reichweite max. 6m
- Zeiteinstellung 5sek.-8min.
- Inkl. Dauerlichtfunktion

- Incl. motion detector with microwave sensor
- Range max. 6m
- Time setting 5sec.-8min.
- Incl. continuous light function

- Détecteur de mouvement incl.
- Portée max. 6m
- Réglage du temps 5sec.-8min.
- Avec fonction d'éclairage permanent

1. 318508TF EAN 4059709004396

Kunststoff-Metall chrom-aluminiumfarbig

Plastic-metal chrome-alu | Plastique-métal chrome-alu

Incl. 1x LED-Platine | 12W | 1.200lm

3.000K

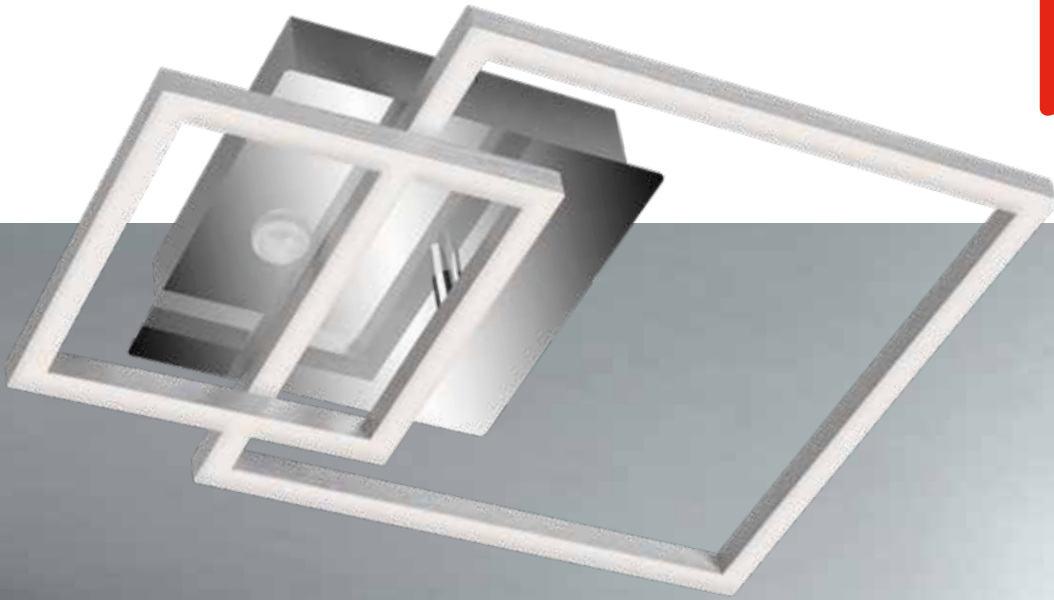
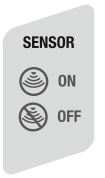

2

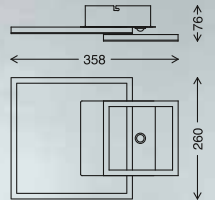

2. 318608TF EAN 4059709004402

Kunststoff-Metall chrom-aluminiumfarbig

Plastic-metal chrome-alu | Plastique-métal chrome-alu

Incl. 1x LED-Platine | 20W | 1.500lm

3.000K

LICHT AN BEI BEWEGUNG

Light on while moving / Éclairage par mouvement

LIGHTS
WOLGA



1+2

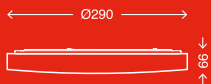

1-2 HIGHLIGHTS

- Inkl. Bewegungsmelder mit Microwave Sensor
- Reichweite max. 8m
- Zeiteinstellung 5sek., 1min., 3min., 10min.
- Inkl. Dauerlichtfunktion
- Dämmerungssensor aus oder <25lux
- Incl. motion detector with microwave sensor
- Range max. 8m
- Time setting 5sec., 1min., 3min., 10min.
- Incl. continuous light function
- Twilight sensor off or <25lux
- Détecteur de mouvement incl.
- Portée max. 8m
- Réglage du temps 5sec., 1min., 3min., 10min.
- Avec fonction d'éclairage permanent
- Capteur crépusculaire éteint ou <25lux

1. 601506TF EAN 4059709002385

Kunststoff-Metall weiß

Plastic-metal white | Plastique-métal blanc
Incl. 1x LED-Platine | 12W | 1.200lm
4.000K

2. 601604TF EAN 4059709002392

Kunststoff-Metall silberfarbig-weiß

Plastic-metal silver-white | Plastique-métal argenté-blanc
Incl. 1x LED-Platine | 12W | 1.200lm
4.000K

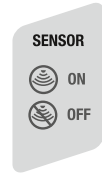

2



LIGHTS
BOLWA

LIGHTS
NEWA



3

3-4 HIGH-LIGHTS

- Inkl. Bewegungsmelder mit Microwave Sensor
- Reichweite max. 8m
- Zeiteinstellung 5sek., 30sek., 1min., 3min., 5min., 10min., 20min., 30min.
- 2lux, 10lux, 25lux, 50lux, OFF
- Incl. motion detector with microwave sensor
- Range max. 8m
- Time setting 5sec., 30sec., 1min., 3min., 5min., 10min., 20min., 30min.
- 2lux, 10lux, 25lux, 50lux, OFF
- Détecteur de mouvement incl.
- Portée max. 8m
- Réglage du temps 5sec., 30sec., 1min., 3min., 5min., 10min., 20min., 30min.
- 2lux, 10lux, 25lux, 50lux, OFF

4



3+4



3. 318405TF EAN 4059709004372
Kunststoff-Metall schwarz-weiß | Plastic-metal black-white | Plastique-métal noir-blanc
Incl. 1x LED-Platine | 16W | 1.500lm
4.000K

4. 318408TF EAN 4059709004389
Kunststoff-Metall chrom-weiß | Plastic-metal chrome-white | Plastique-métal chrome-blanc
Incl. 1x LED-Platine | 16W | 1.500lm
4.000K

LICHT AN BEI BEWEGUNG

Light on while moving / Éclairage par mouvement

LIGHTS
KAMA



2

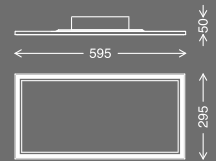

1

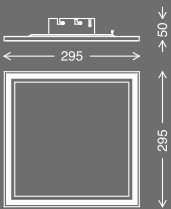

1. 308606TF EAN 4059709002347
Kunststoff-Metall weiß
Plastic-metal white | Plastique-métal blanc
Incl. 1x LED-Platine | 13W | 1.300lm
4.000K

2. 308706TF EAN 4059709002354
Kunststoff-Metall weiß
Plastic-metal white | Plastique-métal blanc
Incl. 1x LED-Platine | 36W | 3.600lm
4.000K

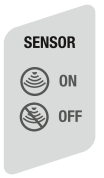

3

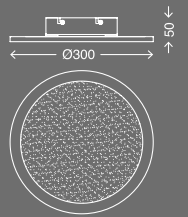

1-3 HIGHLIGHTS

- Inkl. Bewegungsmelder mit Microwave Sensor
- Reichweite max. 8m
- Zeiteinstellung 5sek., 1min., 3min., 10min.
- Inkl. Dauerlichtfunktion
- Dämmerungssensor aus oder <25lux

- Incl. motion detector with microwave sensor
- Range max. 8m
- Time setting 5sec., 1min., 3min., 10min.
- Incl. continuous light function
- Twilight sensor off or <25lux

- Détecteur de mouvement incl.
- Portée max. 8m
- Réglage du temps 5sec., 1min., 3min., 10min.
- Avec fonction d'éclairage permanent
- Capteur crépusculaire éteint ou <25lux



3. 309004TF EAN 4059709002439

Kunststoff-Metall chrom matt-weiß

Plastic-metal chrome satin-white | chrome mat-blanc

Incl. 1x LED-Platine | 20W | 1.600lm

4.000K

LICHT AN BEI BEWEGUNG

Light on while moving / Éclairage par mouvement

LIGHTS

PETSCHORA

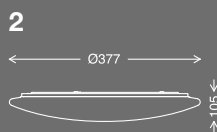
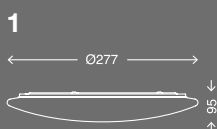

1. 601706TF EAN 4059709002408

Kunststoff-Metall weiß

Plastic-metal white | Plastique-métal blanc

Incl. 1x LED-Platine | 12W | 1.200lm

4.000K

2. 601806TF EAN 4059709002415

Kunststoff-Metall weiß

Plastic-metal white | Plastique-métal blanc

Incl. 1x LED-Platine | 24W | 2.200lm

4.000K

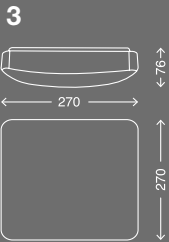
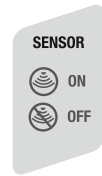

1-3 HIGHLIGHTS

- Inkl. Bewegungsmelder mit Microwave Sensor
- Reichweite max. 8m
- Zeiteinstellung 5sek., 1min., 3min., 10min.
- Inkl. Dauerlichtfunktion
- Dämmerungssensor aus oder <25lux
- Incl. motion detector with microwave sensor
- Range max. 8m
- Time setting 5sec., 1min., 3min., 10min.
- Incl. continuous light function
- Twilight sensor off or <525lux
- Détecteur de mouvement incl.
- Portée max. 8m
- Réglage du temps 5sec., 1min., 3min., 10min.
- Avec fonction d'éclairage permanent
- Capteur crépusculaire éteint ou <25lux



Inkl. Sternendekor
Incl. star decor
Décor ciel étoilé incl.

3. 601906TF EAN 4059709002422

Kunststoff-Metall weiß

Plastic-metal white | Plastique-métal blanc
Incl. 1x LED-Platine | 12W | 1.200lm
4.000K

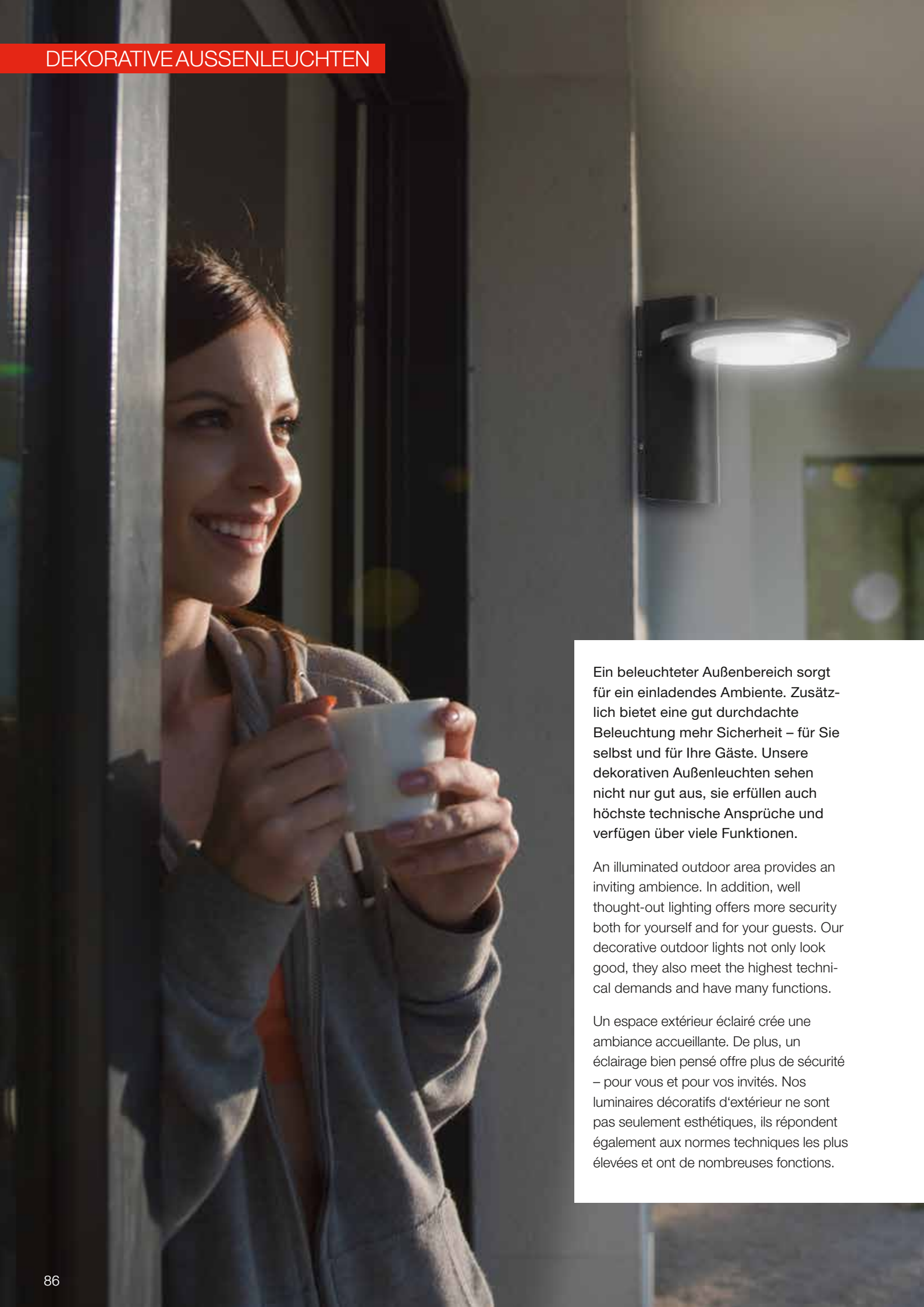

Ein beleuchteter Außenbereich sorgt für ein einladendes Ambiente. Zusätzlich bietet eine gut durchdachte Beleuchtung mehr Sicherheit – für Sie selbst und für Ihre Gäste. Unsere dekorativen Außenleuchten sehen nicht nur gut aus, sie erfüllen auch höchste technische Ansprüche und verfügen über viele Funktionen.

An illuminated outdoor area provides an inviting ambience. In addition, well thought-out lighting offers more security both for yourself and for your guests. Our decorative outdoor lights not only look good, they also meet the highest technical demands and have many functions.

Un espace extérieur éclairé crée une ambiance accueillante. De plus, un éclairage bien pensé offre plus de sécurité – pour vous et pour vos invités. Nos luminaires décoratifs d'extérieur ne sont pas seulement esthétiques, ils répondent également aux normes techniques les plus élevées et ont de nombreuses fonctions.

LICHTINSPIRATION FÜR MEHR KOMFORT IM AUSSENBEREICH.

Light inspiration for more comfort in outdoor areas.

Une inspiration lumineuse pour plus de confort à l'extérieur.

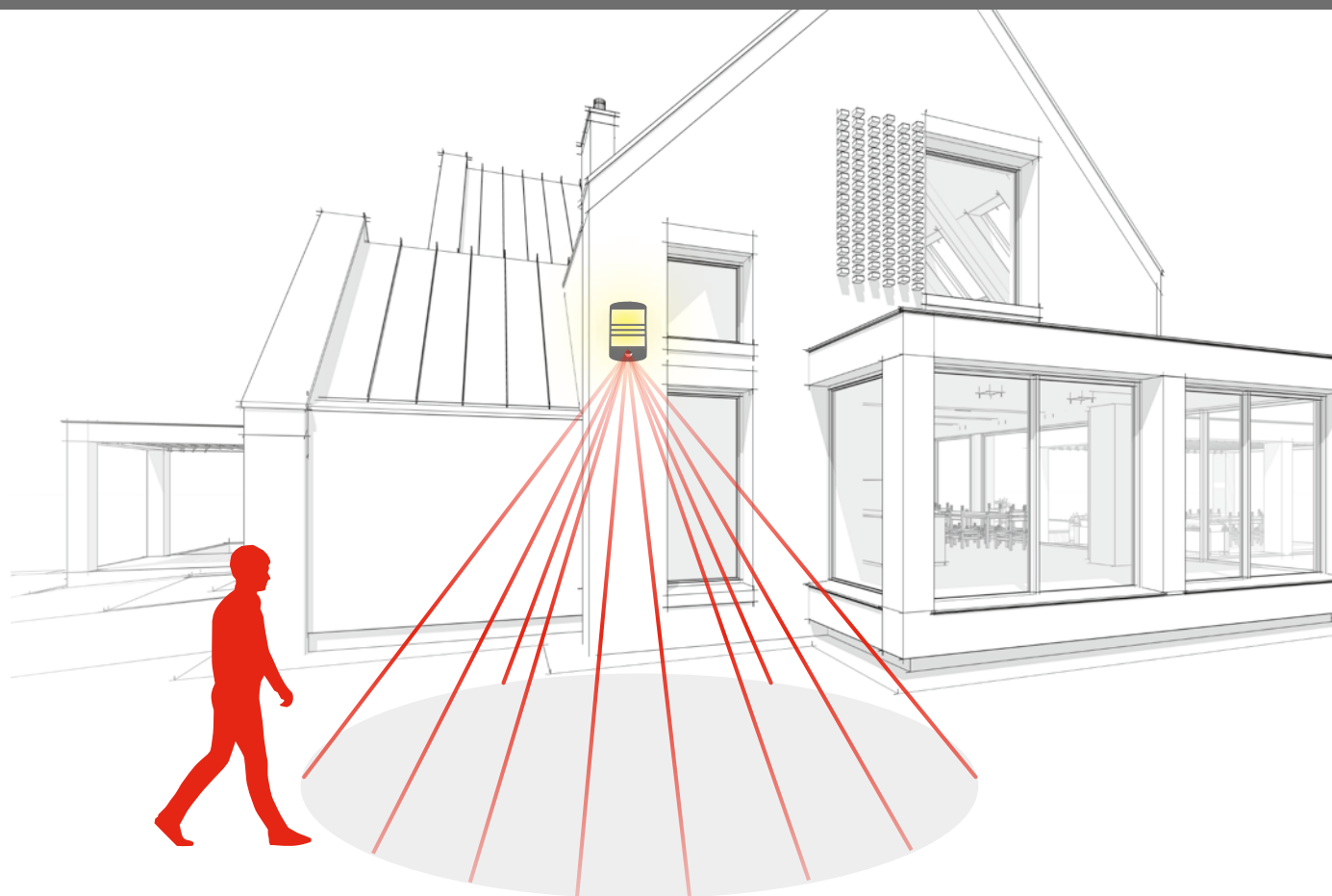

POINT OF SALE

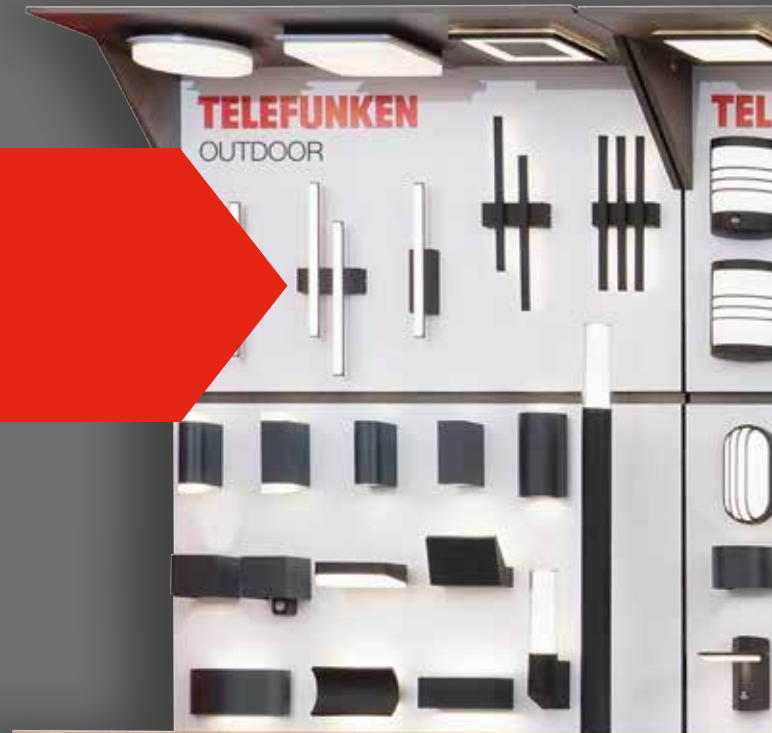

Unser Beitrag für
eine grünere Zukunft:
Karton statt Blister!



Our contribution to a greener future: Cardboard instead of blister! / Notre contribution à un avenir plus vert: du carton au lieu d'un blister.



DEKORATIVE AUSSENLEUCHTEN

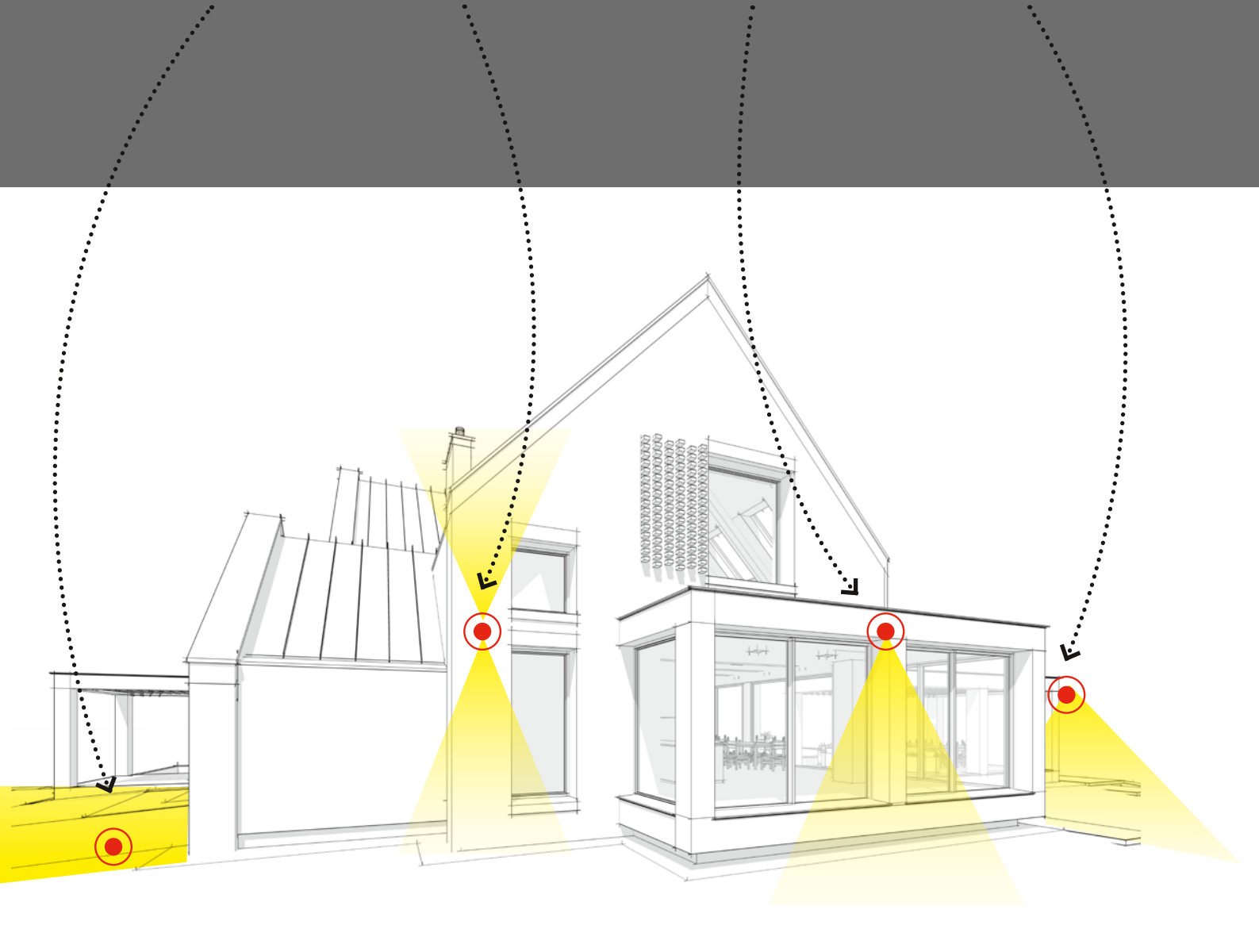

BELEUCHTUNGSGIDEEN RUND UMS HAUS.

Lighting ideas around the house.

Des idées d'éclairage autour de la maison.

Moderne Außenbeleuchtung ist heute kaum noch wegzudenken, energiesparend und vor allem sicher muss es sein!

Das alles bringen die Beleuchtungsideen rund ums Haus von Telefunken auf den Punkt. Intelligente Sensoren überwachen unauffällig Bewegungen rund ums Haus.

Die Bewegungsmelder können separat angebracht und mit den Leuchten verbunden werden. Neben einem wundervollen Lichtambiente und einem wertigen Anblick des Grundstückes, sorgen sie neben einem absoluten Wohlfühlfaktor auch für maximale Sicherheit. Sicherheit ist aber nicht nur bei ungebetenen Gästen ein großes Thema, auch wenn ein Notfall eintritt, sind gut beleuchtete Wege das A und O. Darüber hinaus muss die Hausnummer von der Straße aus gut erkennbar sein, mit Telefunken kein Problem. Ein rundes Konzept und einfach gut durchdacht!

These days it is hard to imagine life without modern outdoor lighting; it has to be energy-saving and, most importantly, safe!

Telefunken's lighting ideas for around the house bring all this together. Intelligent sensors inconspicuously monitor movements around the house.

The motion detectors can be mounted separately and connected to the lights. In addition to a wonderful light ambience and a valuable view of the property, they also provide a feel-good factor as well as maximum security. However, safety is not only a major issue for uninvited guests; if an emergency occurs, well lit paths are essential. In addition, the house number must be clearly visible from the street, no problem with Telefunken. It is quite simply a well-rounded and thought out concept!

Les lampes d'extérieur modernes font partie de notre quotidien, mais il s'agit avant tout de miser sur leur sécurité et leur écologie!

Nos idées d'éclairage sont installées tout autour de la maison Telefunken. Des capteurs intelligents surveillent discrètement les mouvements autour de la maison.

Les détecteurs de mouvement peuvent être montés séparément, avant d'y être connectés. En plus de créer une merveilleuse ambiance lumineuse et de mettre en valeur le terrain, ces produits procurent un bien-être absolu et un niveau maximal de sécurité. Mais le thème de la sécurité n'est pas seulement évoqué pour éloigner les nuisibles: en cas d'urgence, avoir des chemins bien éclairés est indispensable. En outre, le numéro d'une maison doit être bien visible dans la rue. Telefunken a la solution à ces problématiques. Un concept idéal, étudié de A à Z!

LICHT ALS WEGWEISER

Light as a guide / Un guide de lumière



1



2

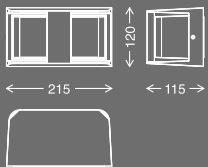

1. 321004TF EAN 4059709005157
Kunststoff-Metall silberfarbig
 Plastic-metal silver | Plastique-métal argenté
 1x E27 max. 12W
 exkl. Leuchtmittel
 excl. bulb | ampoule excl.

2. 321005TF EAN 4059709005140
Kunststoff-Metall schwarz
 Plastic-metal black | Plastique-métal noir
 1x E27 max. 12W
 exkl. Leuchtmittel
 excl. bulb | ampoule excl.

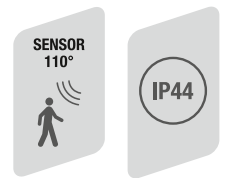

3

LIGHTS BOXI MOVE



4

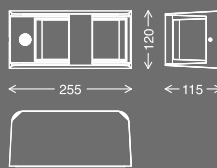

3-4 HIGHLIGHTS

- Inkl. Bewegungsmelder
 - Erfassungsbereich 10m
 - Erfassungswinkel 110°
 - Zeiteinstellung 5sek.-5min.
 - Dämmerungssensor 10-2.000lux
-
- Incl. motion detector
 - Detection range 10m
 - Detection angle 110°
 - Time setting 5sec.-5min.
 - Twilight sensor 10-2.000lux
-
- Détecteur de mouvement incl.
 - Champ de détection 10m
 - Angle de détection 110°
 - Réglage du temps 5sec.-5min.
 - Détecteur crépusculaire 10-2.000lux

3. 321104TF EAN 4059709005171
Kunststoff-Metall silberfarbig
 Plastic-metal silver | Plastique-métal argenté
 1x E27 max. 12W
 exkl. Leuchtmittel
 excl. bulb | ampoule excl.

4. 321105TF EAN 4059709005164
Kunststoff-Metall schwarz
 Plastic-metal black | Plastique-métal noir
 1x E27 max. 12W
 exkl. Leuchtmittel
 excl. bulb | ampoule excl.

EFFEKTVOLLES LICHT

Light with effect / Effets lumineux



1



2

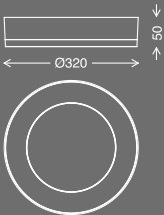

LIGHTS
RIXI



1-5 HIGH-LIGHTS

- Zeitlose Optik
- Timeless look
- Optique intemporelle

1. 320904TF EAN 4059709005133

Kunststoff-Metall silberfarbig

Plastic-metal silver | Plastique-métal argenté
Incl. 1x LED-Platine | 24W | 2.600lm
4.000K

2. 320905TF EAN 4059709005126

Kunststoff-Metall schwarz

Plastic-metal black | Plastique-métal noir
Incl. 1x LED-Platine | 24W | 2.600lm
4.000K

LIGHTS
PUKA

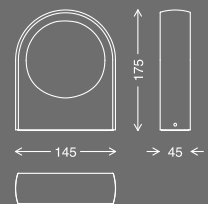
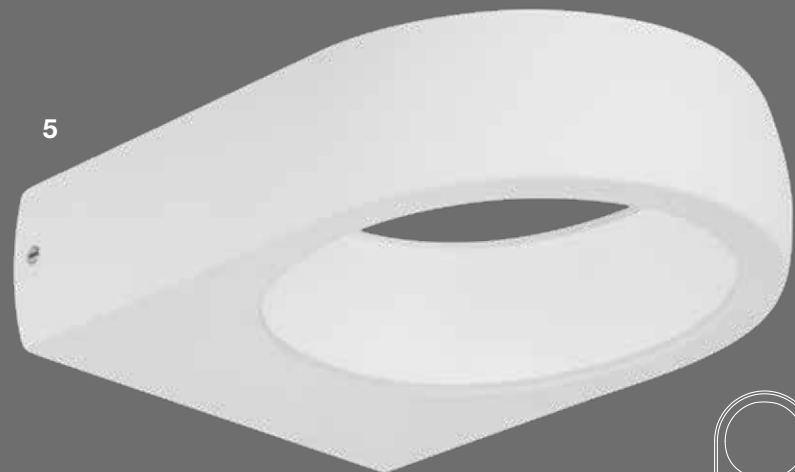
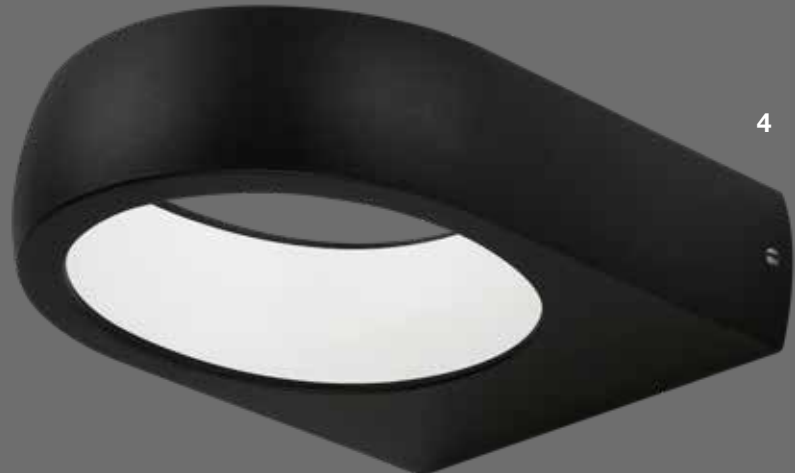
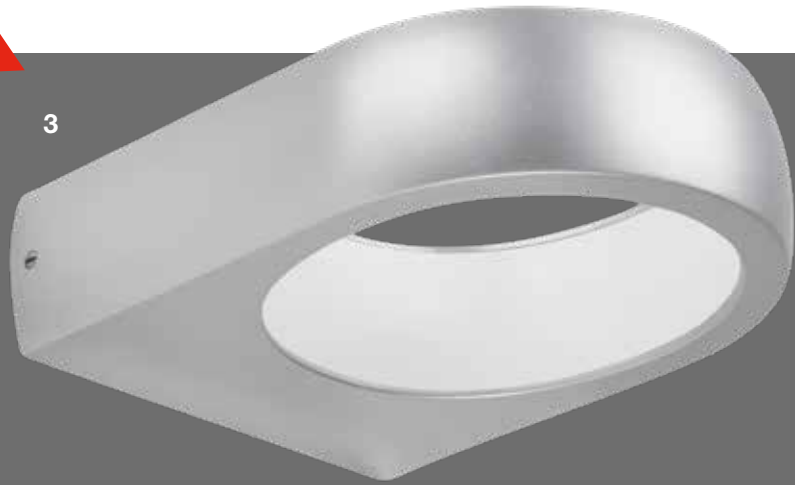

3. 320204TF EAN 4059709004983
Kunststoff-Metall silberfarbig
 Plastic-metal silver | Plastique-métal argenté
 Incl. 1x LED-Platine | 7,5W | 680lm
 4.000K

4. 320205TF EAN 4059709004969
Kunststoff-Metall schwarz
 Plastic-metal black | Plastique-métal noir
 Incl. 1x LED-Platine | 7,5W | 680lm
 4.000K

5. 320206TF EAN 4059709004976
Kunststoff-Metall weiß
 Plastic-metal white | Plastique-métal blanc
 Incl. 1x LED-Platine | 7,5W | 680lm
 4.000K

EFFEKTVOLLES LICHT

Light with effect / Effets lumineux

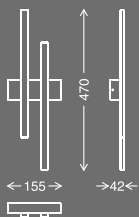
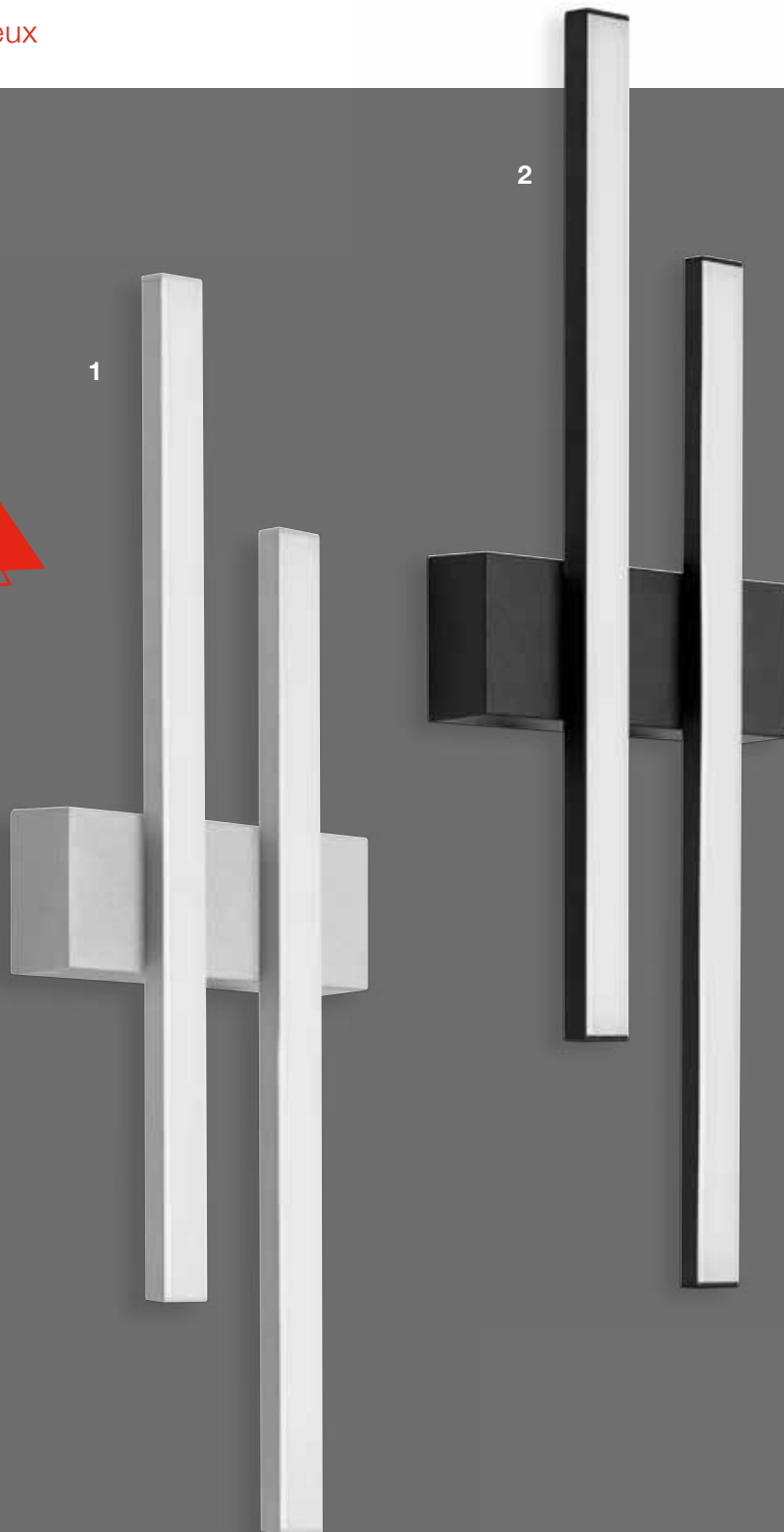

1. 313004TF EAN 4059709003252
Kunststoff-Metall silberfarbig
Plastic-metal silver | Plastique-métal argenté
Incl. 2x LED-Platine | 4W | 480lm
4.000K

2. 313005TF EAN 4059709003245
Kunststoff-Metall schwarz
Plastic-metal black | Plastique-métal noir
Incl. 2x LED-Platine | 4W | 480lm
4.000K



**DIRECT
LIGHT**

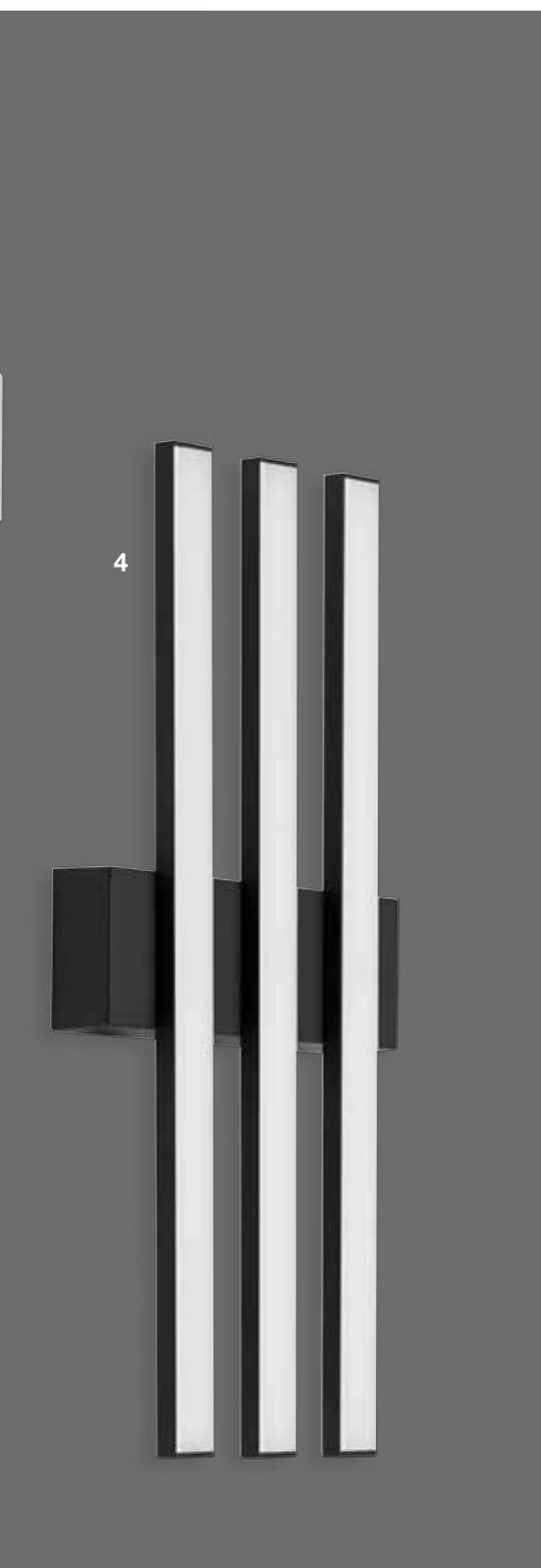
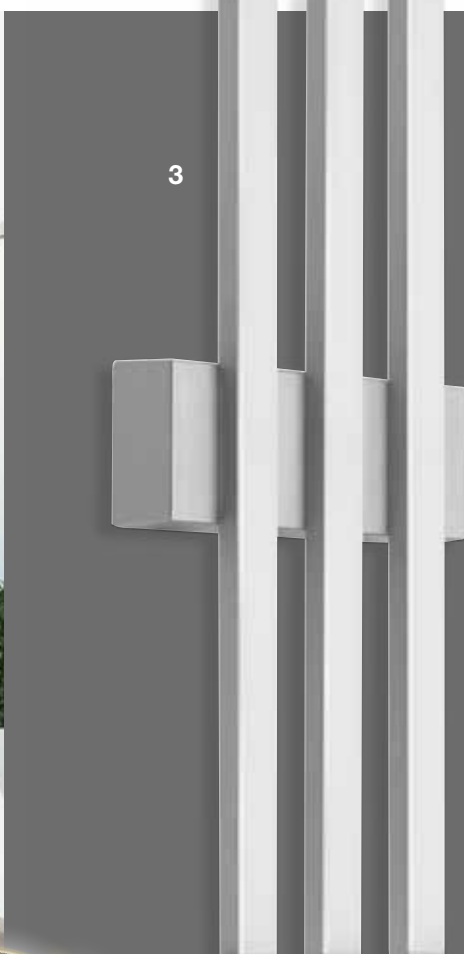

1-4 HIGH-LIGHTS

- Flaches LED-Stab Design
- In 2 Farben erhältlich
- Flat LED stick design
- Available in 2 colours
- Barre LED plate design
- Disponible en 2 couleurs

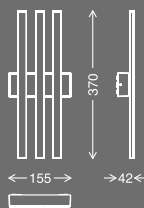

3. 313104TF EAN 4059709003283

Kunststoff-Metall silberfarbig

Plastic-metal silver | Plastique-métal argenté
Incl. 3x LED-Platine | 4W | 480lm
4.000K

4. 313105TF EAN 4059709003276

Kunststoff-Metall schwarz

Plastic-metal black | Plastique-métal noir
Incl. 3x LED-Platine | 4W | 480lm
4.000K

EFFEKTIVOLLES LICHT

Light with effect / Effets lumineux

LIGHTS
GRAZ

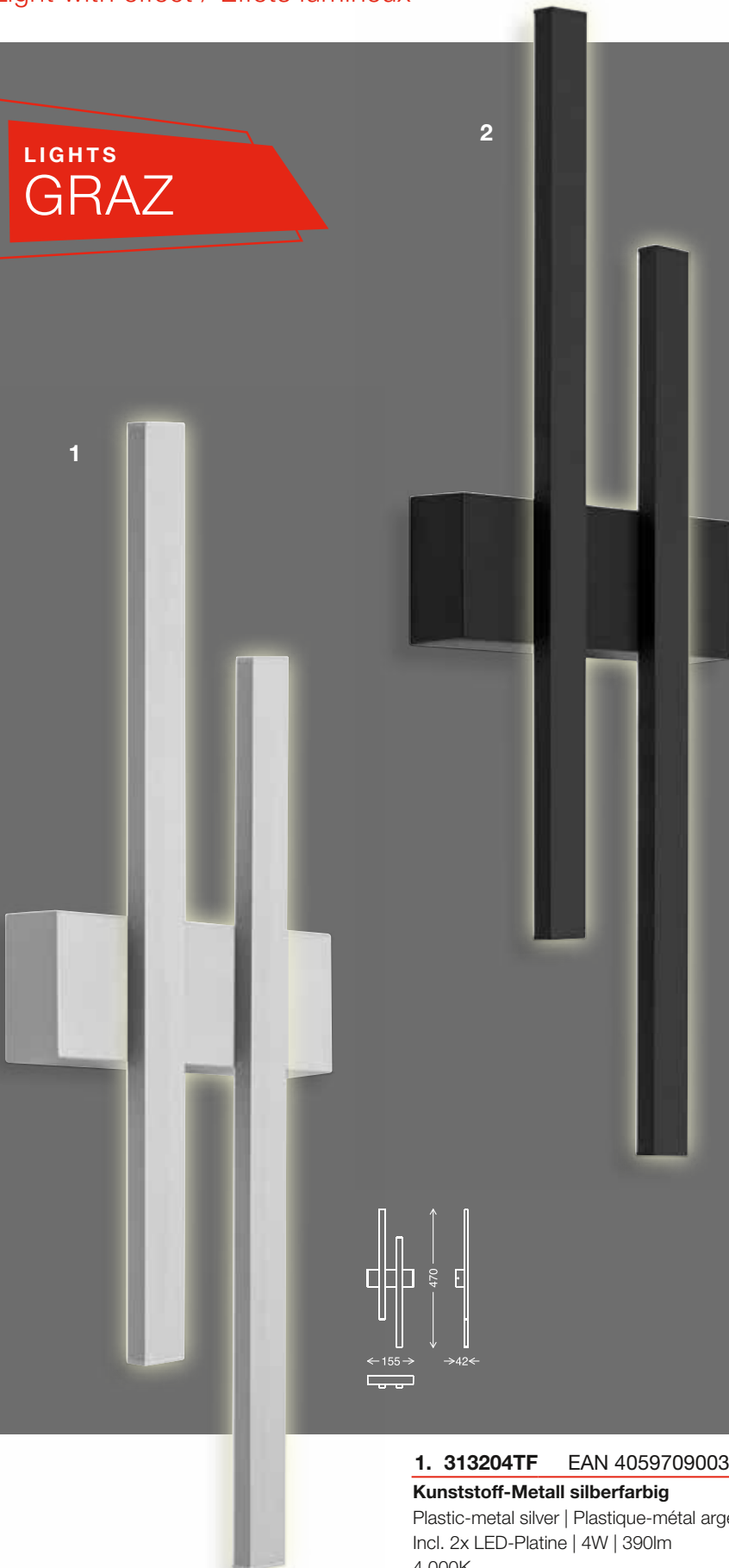

1. 313204TF EAN 4059709003306

Kunststoff-Metall silberfarbig

Plastic-metal silver | Plastique-métal argenté

Incl. 2x LED-Platine | 4W | 390lm

4.000K

2. 313205TF EAN 4059709003290

Kunststoff-Metall schwarz

Plastic-metal black | Plastique-métal noir

Incl. 2x LED-Platine | 4W | 390lm

4.000K

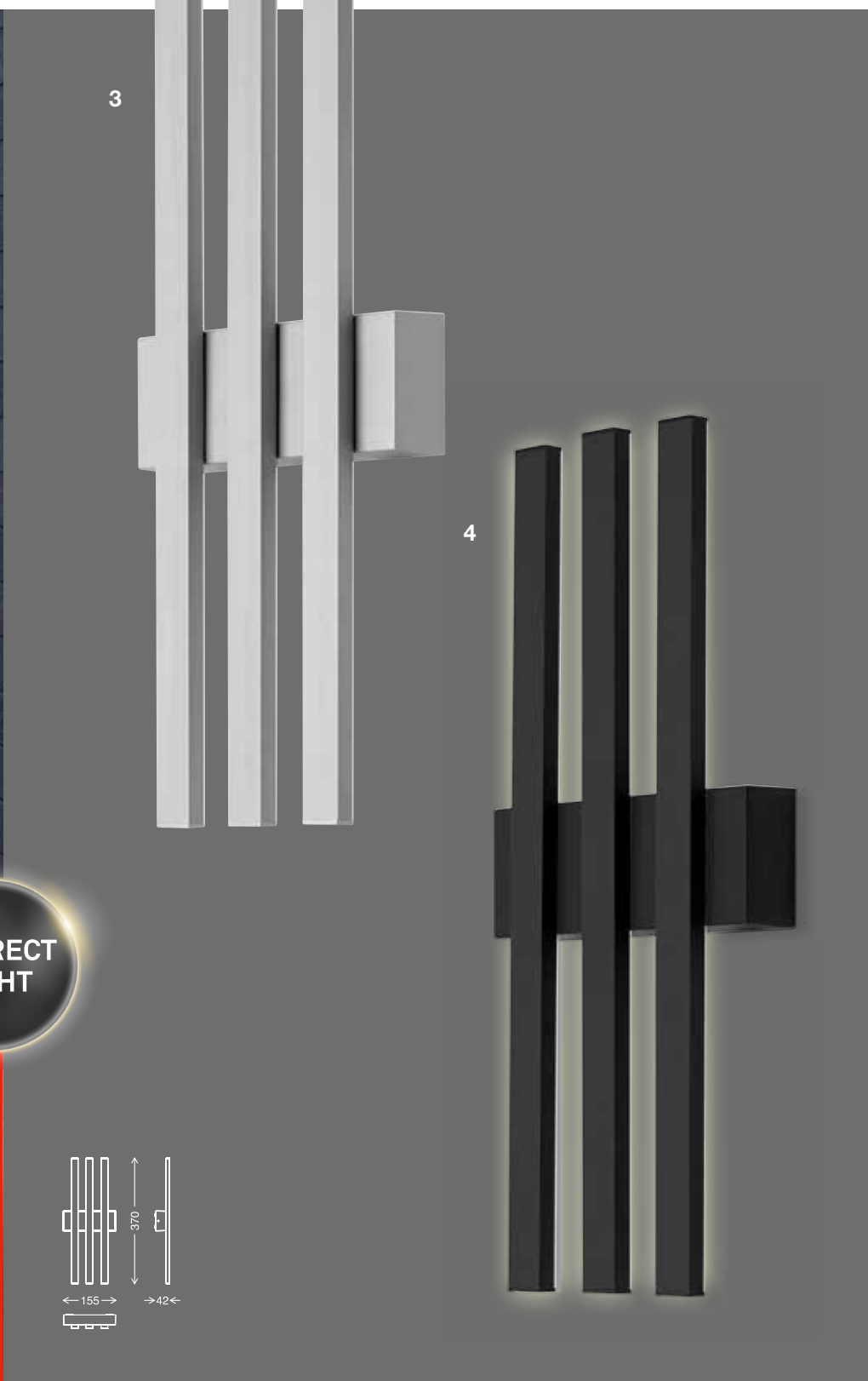

**INDIRECT
LIGHT**

1 - 4 HIGH-LIGHTS

- Flaches LED-Stab Design
- In 2 Farben erhältlich

- Flat LED stick design
- Available in 2 colours

- Barre LED plate design
- Disponible en 2 couleurs

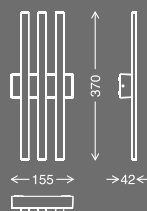

3. 313304TF EAN 4059709003320
Kunststoff-Metall silberfarbig
 Plastic-metal silver | Plastique-métal argenté
 Incl. 3x LED-Platine | 4W | 390lm
 4.000K

4. 313305TF EAN 4059709003313
Kunststoff-Metall schwarz
 Plastic-metal black | Plastique-métal noir
 Incl. 3x LED-Platine | 4W | 390lm
 4.000K

LICHT ALS WEGWEISER

Light as a guide / Un guide de lumière



1-3 HIGHLIGHTS

- Niedrige Aufbauhöhe
- Mit Hausnummerset individualisierbar (gilt nicht für Nr. 3)
- Low installation height
- With house number set customizable (this does not apply for item nr. 3)
- Capteur à infrarouge
- Avec numéro de maison défini personnalisable (ne s'applique pas pour n° 3)

1. 313405TF EAN 4059709003337

Kunststoff-Metall schwarz

Plastic-metal black | Plastique-métal noir
Incl. 1x LED-Platine | 15W | 2.000lm
4.000K

2. 313406TF EAN 4059709003344

Kunststoff-Metall weiß

Plastic-metal white | Plastique-métal blanc
Incl. 1x LED-Platine | 15W | 2.000lm
4.000K

3. 315805TF EAN 4059709003849

Kunststoff-Metall schwarz

Plastic-metal black | Plastique-métal noir
Incl. 1x LED-Platine | 15W | 2.000lm
4.000K



4



5



4-6 HIGHLIGHTS

- Inkl. Bewegungsmelder
- Erfassungsbereich 6m
- Erfassungswinkel 120°
- Zeiteinstellung 5sek. - 8min.
- Dämmerungssensor 10-2.000lux

- Incl. motion detector
- Detection range 6m
- Detection angle 120°
- Time setting 5sec.-8min.
- Twilight sensor 10-2.000lux

- Détecteur de mouvement incl.
- Champ de détection 6m
- Angle de détection 120°
- Réglage du temps 5sec.-8min.
- Détecteur crépusculaire 10-2.000lux



6

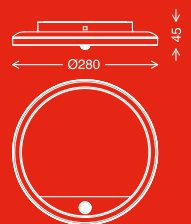

4. 313705TF EAN 4059709003399
Kunststoff-Metall schwarz
 Plastic-metal black | Plastique-métal noir
 Incl. 1x LED-Platine | 15W | 2.000lm
 4.000K

5. 313706TF EAN 4059709003405
Kunststoff-Metall weiß
 Plastic-metal white | Plastique-métal blanc
 Incl. 1x LED-Platine | 15W | 2.000lm
 4.000K

6. 314800TF EAN 4059709003610
Hausnummern-Set
 House numbers set | Set numéro de maison
 inkl. 3x 0-9, 1x A-H

LICHT ALS WEGWEISER

Light as a guide / Un guide de lumière

2



1



3



LIGHTS
OLPE

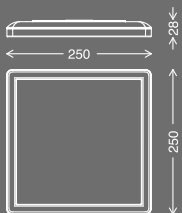

1-3 HIGH-LIGHTS

- Niedrige Aufbauhöhe
- Mit Hausnummerset individualisierbar (gilt nicht für Nr. 3)
- Low installation height
- With house number set customizable (this does not apply for item nr. 3)
- Faible hauteur de construction
- Avec numéro de maison défini personnalisable (ne s'applique pas pour n° 3)

1. 313505TF EAN 4059709003351

Kunststoff schwarz

Plastic black | Plastique noir
Incl. 1x LED-Platine | 15W | 2.000lm
4.000K

2. 313506TF EAN 4059709003368

Kunststoff weiß

Plastic white | Plastique blanc
Incl. 1x LED-Platine | 15W | 2.000lm
4.000K

3. 315905TF EAN 4059709003856

Kunststoff schwarz

Plastic black | Plastique noir
Incl. 1x LED-Platine | 15W | 2.000lm
4.000K



LIGHTS NIZZA

5



4-6 HIGH-LIGHTS

- Inkl. Bewegungsmelder
- Erfassungsbereich 6m
- Erfassungswinkel 120°
- Zeiteinstellung 5sek. - 8min.
- Dämmerungssensor 10-2.000lux

- Incl. motion detector
- Detection range 6m
- Detection angle 120°
- Time setting 5sec.-8min.
- Twilight sensor 10-2.000lux
- Détecteur de mouvement incl.
- Champ de détection 6m
- Angle de détection 120°
- Réglage du temps 5sec.-8min.
- Détecteur crépusculaire 10-2.000lux

4



EQUIPMENT NUMBERS

6

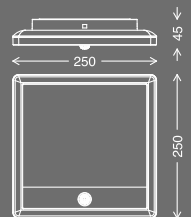

4. 313805TF EAN 4059709003412
Kunststoff schwarz
 Plastic black | Plastique noir
 Incl. 1x LED-Platine | 15W | 2.000lm
 4.000K

5. 313806TF EAN 4059709003429
Kunststoff weiß
 Plastic white | Plastique blanc
 Incl. 1x LED-Platine | 15W | 2.000lm
 4.000K

6. 314800TF EAN 4059709003610
Hausnummern-Set
 House numbers set | Set numéro de maison
 inkl. 3x 0-9, 1x A-H

LICHT ALS WEGWEISER

Light as a guide / Un guide de lumière

LIGHTS
NIZZA

1



2

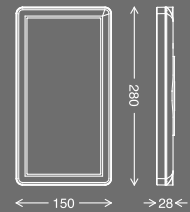

BACK
LIGHT
EFFECT

1-2 HIGH-
LIGHTS

- Niedrige Aufbauhöhe
- Mit Hausnummerset individualisierbar
- Low installation height
- With house number set customizable
- Faible hauteur de construction
- Avec numéro de maison défini personnalisable

1. 313604TF EAN 4059709003382

Kunststoff silberfarbig

Plastic silver | Plastique argenté
Incl. 1x LED-Platine | 16W | 2.000lm
4.000K

2. 313605TF EAN 4059709003375

Kunststoff schwarz

Plastic black | Plastique noir
Incl. 1x LED-Platine | 16W | 2.000lm
4.000K



3



4

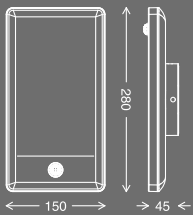

3-5 HIGH-LIGHTS

- Inkl. Bewegungsmelder
- Erfassungsbereich 6m
- Erfassungswinkel 120°
- Zeiteinstellung 5sek.-8min.
- Dämmerungssensor 10-2.000lux

- Incl. motion detector
- Detection range 6m
- Detection angle 120°
- Time setting 5sec.-8min.
- Twilight sensor 10-2.000lux

- Détecteur de mouvement incl.
- Champ de détection 6m
- Angle de détection 120°
- Réglage du temps 5sec.-8min.
- Détecteur crépusculaire 10-2.000lux

EQUIPMENT NUMBERS

5



3. 313904TF EAN 4059709003443

Kunststoff silberfarbig

Plastic silver | Plastique argenté

Incl. 1x LED-Platine | 16W | 2.000lm

4.000K

4. 313905TF EAN 4059709003436

Kunststoff schwarz

Plastic black | Plastique noir

Incl. 1x LED-Platine | 16W | 2.000lm

4.000K

5. 314800TF EAN 4059709003610

Hausnummern-Set

House numbers set | Set numéro de maison

inkl. 3x 0-9, 1x A-H

LEUCHTEN-TRIO

Series of 3 luminaires / Série de 3 luminaires

LIGHTS
BRISTOL



1

1+4

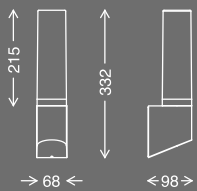

2



3



1. 311306TF EAN 4059709002958

Kunststoff-Metall weiß

Plastic-metal white | Plastique-métal blanc
Incl. 1x LED-Platine | 8W | 850lm
4.000K

2. 311406TF EAN 4059709002965

Kunststoff-Metall weiß

Plastic-metal white | Plastique-métal blanc
Incl. 1x LED-Platine | 8W | 850lm
4.000K

3. 311506TF EAN 4059709002972

Kunststoff-Metall weiß

Plastic-metal white | Plastique-métal blanc
Incl. 1x LED-Platine | 8W | 850lm
4.000K



1-6 HIGH-LIGHTS

- Einheitliches Design
- 3 Größen verfügbar
- Uniform design
- 3 sizes available
- Conception uniforme
- 3 Tailles disponibles

4



2+5

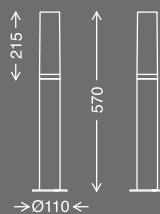

3+6

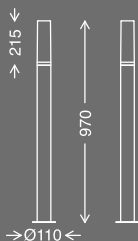

6



5



4. 311305TF EAN 4059709002866

Kunststoff-Metall schwarz

Plastic-metal black | Plastique-métal noir
Incl. 1x LED-Platine | 8W | 850lm
4.000K

5. 311405TF EAN 4059709002873

Kunststoff-Metall schwarz

Plastic-metal black | Plastique-métal noir
Incl. 1x LED-Platine | 8W | 850lm
4.000K

6. 311505TF EAN 4059709002880

Kunststoff-Metall schwarz

Plastic-metal black | Plastique-métal noir
Incl. 1x LED-Platine | 8W | 850lm
4.000K

LICHT ALS WEGWEISER

Light as a guide / Un guide de lumière

LIGHTS
GENT

1

2

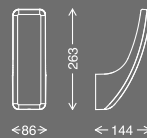

1. 311604TF EAN 4059709002989

Kunststoff-Metall silberfarbig

Plastic-metal silver | Plastique-métal argenté

Incl. 1x LED-Platine | 15W | 1.800lm

4.000K

2. 311605TF EAN 4059709002897

Kunststoff-Metall schwarz

Plastic-metal black | Plastique-métal noir

Incl. 1x LED-Platine | 15W | 1.800lm

4.000K



LIGHTS MAINZ

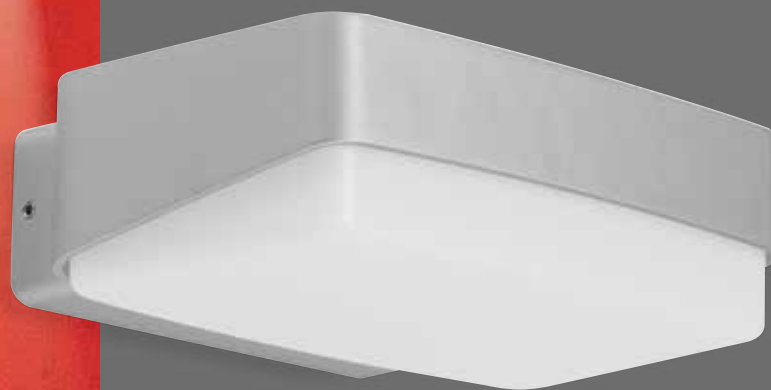

3

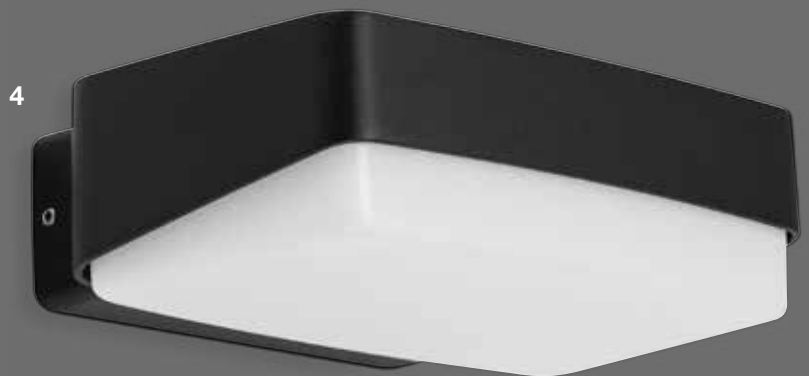

4

1 - 4 HIGH-LIGHTS

- Setzt gekonnt Lichtakzente
- Sets skilfully light accents
- Éclairage habilement directionnel

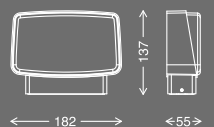

3. 312204TF EAN 4059709003122

Kunststoff-Metall silberfarbig

Plastic-metal silver | Plastique-métal argenté
Incl. 1x LED-Platine | 14W | 1.500lm
4.000K

4. 312205TF EAN 4059709003061

Kunststoff-Metall schwarz

Plastic-metal black | Plastique-métal noir
Incl. 1x LED-Platine | 14W | 1.500lm
4.000K

ECKIGE DESIGNLEUCHTEN

Rectangle design lamps / Luminaires design rectangle

1

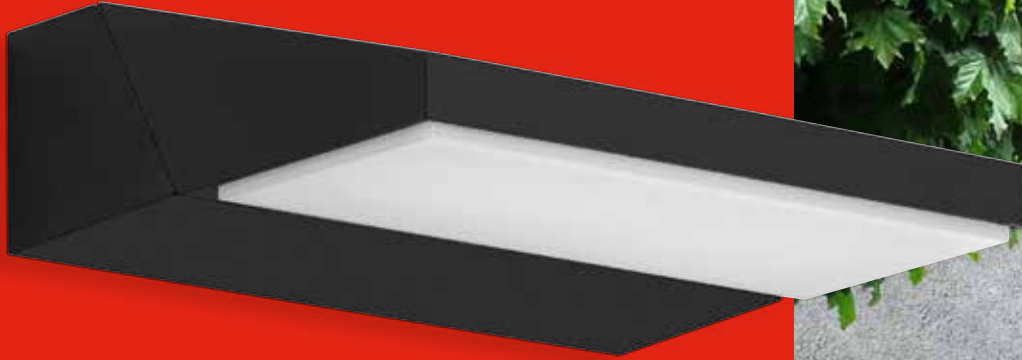

LIGHTS
BERGEN

2

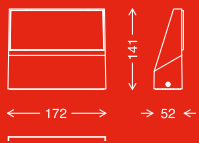
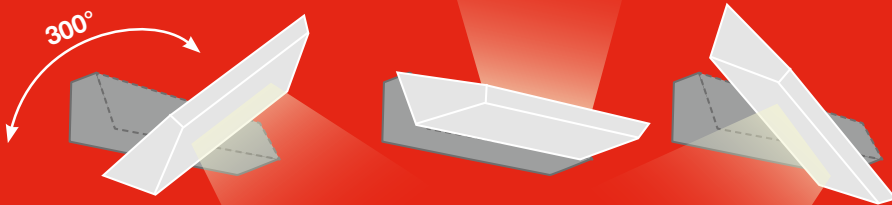

1-2 HIGH-
LIGHTS

- Dauerhaftes Licht
- Drehbarer Lichtstrahl
- Continuous light
- Rotatable light beam
- Lumière continue
- Projection lumineuse rotative

1. 312605TF EAN 4059709003108

Kunststoff-Metall schwarz

Plastic-metal black | Plastique-métal noir
Incl. 1x LED-Platine | 10W | 1.100lm
4.000K

2. 312606TF EAN 4059709003160

Kunststoff-Metall weiß

Plastic-metal white | Plastique-métal blanc
Incl. 1x LED-Platine | 10W | 1.100lm
4.000K

HQ
LED
20.000h

IP44



3

LIGHTS
MONACO



4

3-4 HIGHLIGHTS

- Klare Glasabdeckung
- Clear glass cover
- Plaque de recouvrement en verre clair

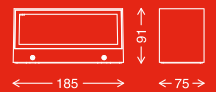

3. 314405TF EAN 4059709003535

Metall-Glas schwarz

Metal-glass black | Métal-verre noir
Incl. 2x LED-Platine | 6W | 600lm
4.000K

4. 314406TF EAN 4059709003542

Metall-Glas weiß

Metal-glass white | Métal-verre blanc
Incl. 2x LED-Platine | 6W | 600lm
4.000K



LIGHTS
TOLEDO

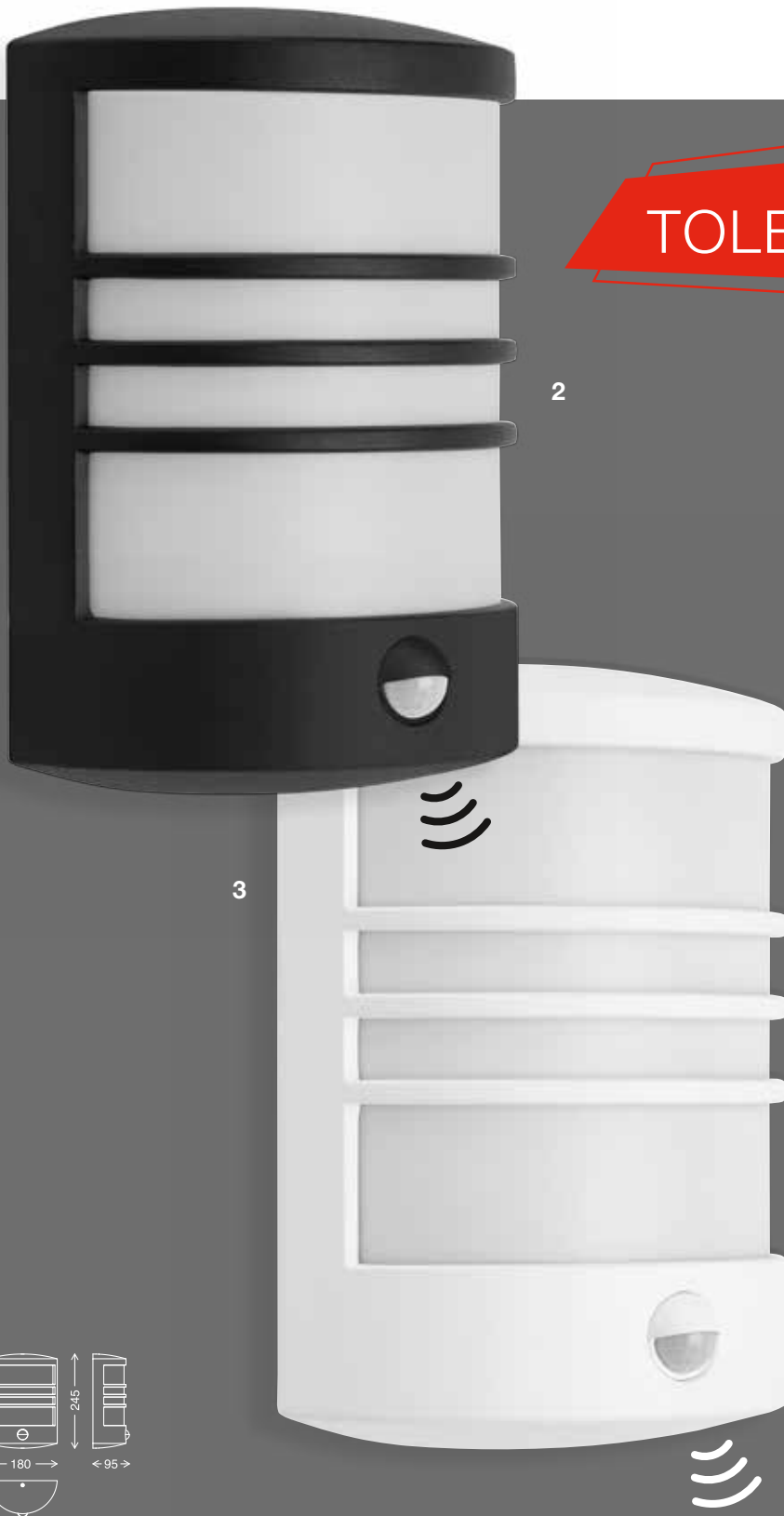

2

3

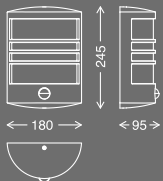

1-2 HIGH-LIGHTS

- Inkl. Bewegungsmelder
- Erfassungsbereich 10m
- Erfassungswinkel 105°
- Zeiteinstellung 8sek.-8min.
- Dämmerungssensor 10-2.000lux

- Incl. motion detector
- Detection range 10m
- Detection angle 105°
- Time setting 8sec.-8min.
- Twilight sensor 10-2.000lux

- Détecteur de mouvement incl.
- Champ de détection 10m
- Angle de détection 105°
- Réglage du temps 8sec.-8min.
- Détecteur crépusculaire 10-2.000lux

1. 315505TF EAN 4059709003771
Kunststoff-Metall schwarz
 Plastic-metal black | Plastique-métal noir
 Incl. 1x LED-Platine | 12W | 1.200lm
 4.000K

2. 315506TF EAN 4059709003788
Kunststoff-Metall weiß
 Plastic-metal white | Plastique-métal blanc
 Incl. 1x LED-Platine | 12W | 1.200lm
 4.000K

3. 315605TF EAN 4059709003795
Kunststoff schwarz
 Plastic black | Plastique noir
 Incl. 1x LED-Platine | 12W | 1.200lm
 4.000K

LIGHTS PALMA

HQ
LED
20.000h

IP44



3



4

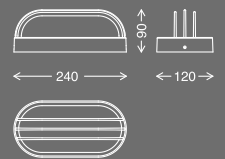

5 HIGH-LIGHTS

- Inkl. Bewegungsmelder
- Erfassungsbereich 8-12m
- Erfassungswinkel 110°
- Zeiteinstellung 10sek.-5min.
- Dämmerungssensor >10lux

- Incl. motion detector
- Detection range 8-12m
- Detection angle 110°
- Time setting 10sec.-5min.
- Twilight sensor >10lux

- Détecteur de mouvement incl.
- Champ de détection 8-12m
- Angle de détection 110°
- Réglage du temps 10sec.-5min.
- Détecteur crépusculaire >10lux

LIGHTS BERN

5

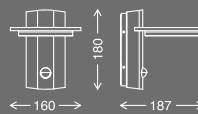

4. 315606TF EAN 4059709003801

Kunststoff weiß

Plastic white | Plastique blanc

Incl. 1x LED-Platine | 12W | 1.200lm
4.000K

5. 312505TF EAN 4059709003092

Kunststoff-Metall schwarz

Plastic-metal black | Plastique-métal noir

Incl. 1x LED-Platine | 10W | 1.200lm
4.000K

PURES DESIGN

Pur Design / Design pur



LIGHTS
CLUDU

1-5 HIGH-LIGHTS

- Zeitlose Optik
- Timeless look
- Optique intemporelle

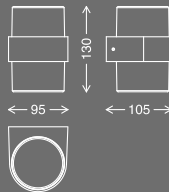

1. 320404TF EAN 4059709005027

Kunststoff-Metall silberfarbig

Plastic-metal silver | Plastique-métal argenté
Incl. 2x LED-Platine | 8W | 800lm
4.000K

2. 320405TF EAN 4059709005010

Kunststoff-Metall schwarz

Plastic-metal black | Plastique-métal noir
Incl. 2x LED-Platine | 8W | 800lm
4.000K

3



LIGHTS
AMPOLO

4



5

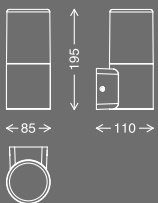

3. 320504TF EAN 4059709005058
Kunststoff-Metall silberfarbig
 Plastic-metal silver | Plastique-métal argenté
 1x E27 max. 12W
 exkl. Leuchtmittel
 excl. bulb | ampoule excl.

4. 320506TF EAN 4059709005041
Kunststoff-Metall weiß
 Plastic-metal white | Plastique-métal blanc
 1x E27 max. 12W
 exkl. Leuchtmittel
 excl. bulb | ampoule excl.

5. 320505TF EAN 4059709005034
Kunststoff-Metall schwarz
 Plastic-metal black | Plastique-métal noir
 1x E27 max. 12W
 exkl. Leuchtmittel
 excl. bulb | ampoule excl.

LED AUSSENWANDLEUCHTEN

PURES DESIGN

Pur Design / Design pur





LIGHTS
SKIPTO

1-2 HIGH-LIGHTS

- Zeitlose Optik
- Timeless look
- Optique intemporelle

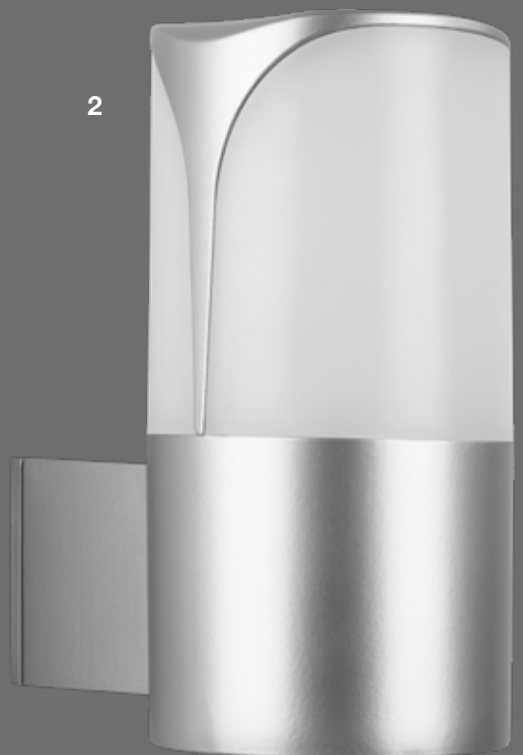
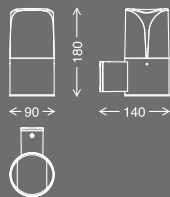

1. 320305TF EAN 4059709004990

Kunststoff-Metall schwarz

Plastic-metal black | Plastique-métal noir
1x E27 max. 12W
exkl. Leuchtmittel
excl. bulb | ampoule excl.

2. 320304TF EAN 4059709005003

Kunststoff-Metall silberfarbig

Plastic-metal silver | Plastique-métal argenté
1x E27 max. 12W
exkl. Leuchtmittel
excl. bulb | ampoule excl.

PURES DESIGN

Pur Design / Design pur



1-3 HIGHLIGHTS

- Up- & Downlight
- Moderne Optik

- Up- & Downlight
- Modern look

- Éclairage faisceaux haut et bas
- Esthétique moderne

1. 312805TF EAN 4059709003184
Metall schwarz
 Metal black | Métal noir
 Incl. 2x LED-Platine | 6W | 600lm
 4.000K

2. 312704TF EAN 4059709003177
Metall-Glas silberfarbig
 Metal-glass silver | Métal-verre argenté
 Incl. 2x LED-Platine | 5,5W | 530lm
 4.000K

3. 312705TF EAN 4059709003115
Metall-Glas schwarz
 Metal-glass black | Métal-verre noir
 Incl. 2x LED-Platine | 5,5W | 530lm
 4.000K



4

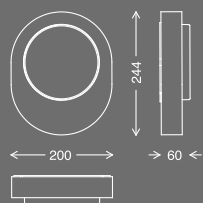

LIGHTS
PRAG



6

LIGHTS
LYON

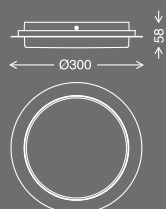

5

2B



4-6 HIGH-LIGHTS

- Mit Hausnummerset individualisierbar
- With house number set customizable
- Avec numéro de maison défini personnalisable

4. 312005TF EAN 4059709003030

Kunststoff-Metall schwarz

Plastic-metal black | Plastique-métal noir
Incl. 1x LED-Platine | 8W | 800lm
4.000K

5. 314502TF EAN 4059709003559

Edelstahl-Kunststoff

Stainless steel-plastic |
Acier inoxydable-plastique
Incl. LED-Platine | 15W | 1.500lm
4.000K

6. 314505TF EAN 4059709003566

Kunststoff-Metall schwarz

Metal-plastic black | Métal-plastique noir
Incl. LED-Platine | 15W | 1.500lm
4.000K

SCHÖNE LICHTEFFEKTE

Nice light effects / Bel effet lumineux



1



LIGHTS
MURCIA

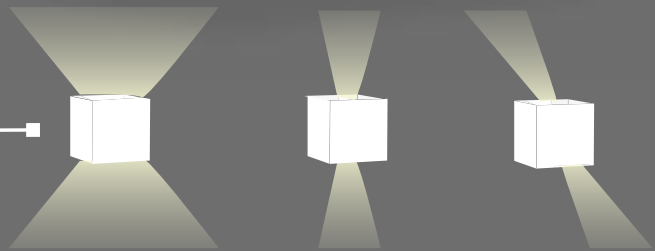

Inkl. Verstellklappen

Incl. adjustable flaps | Clapets de réglage incl.

2



3

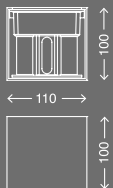
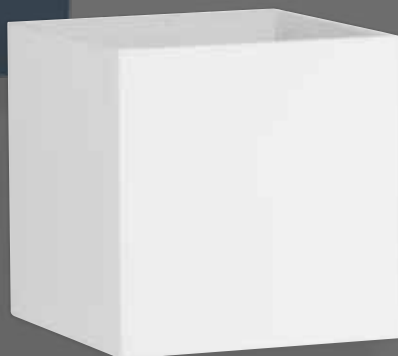

1-3 HIGHLIGHTS

- Ausstrahlwinkel
beidseitig verstellbar
- Beam angle
double-sided adjustable
- Angle du faisceau
réglable des deux côtés

1. 303404TF EAN 4059709000947

Metall silberfarbig

Metal silver | Métal argenté

Incl. 2x LED-Platine | 3W | 300lm

4.000K

2. 303405TF EAN 4059709001944

Metall anthrazit

Metal anthracite | Métal anthracite

Incl. 2x LED-Platine | 3W | 300lm

4.000K

3. 303406TF EAN 4059709000930

Metall weiß

Metal white | Métal blanc

Incl. 2x LED-Platine | 3W | 300lm

4.000K



LIGHTS SORIA



4



4 HIGH- LIGHTS

- GU10 - Leuchtmittel austauschbar
- Für einheitliche Beleuchtung
- Exchangeable GU10 bulb
- For uniform lighting
- GU10 ampoule interchangeable
- Pour un éclairage uniforme

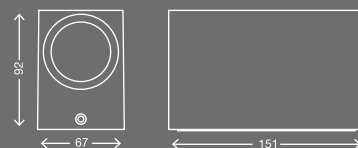

4. 307005TF EAN 4059709002040

Metall anthrazit

Metal anthracite | anthracite

Incl. 2x LED-GU10 | 5W | 400lm

4.000K

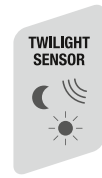

LIGHTS
CARPI

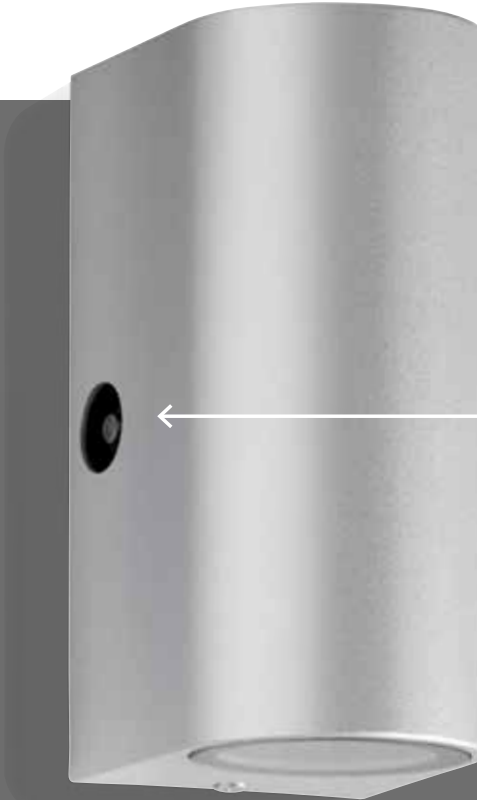

1



Dämmerungssensor
Twilight sensor
Capteur crépusculaire

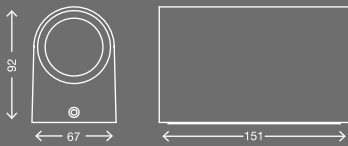

1-2 HIGH-LIGHTS

- Inkl. Dämmerungssensor; aut. AN bei Dämmerung (<10lux); aut. AUS bei Morgenhelligkeit (>40lux)
- Incl. twilight sensor; automatic light on at dusk (<10lux); automatic light off at dawn (>40lux)
- Incl. capteur crépusculaire; la lumière s'allume automatiquement au crépuscule (<10lux); la lumière s'éteint au lever du jour (>40lux)

1. 307104TF EAN 4059709002064
Metall silberfarbig
Metal silver | Métal argenté
Incl. 2x LED-GU10 | 5W | 400lm
4.000K

2. 307106TF EAN 4059709002057
Metall weiß
Metal white | Métal blanc
Incl. 2x LED-GU10 | 5W | 400lm
4.000K



3-4 HIGH-LIGHTS

- GU10 - Leuchtmittel austauschbar
- Exchangeable GU10 bulb
- GU10 ampoule interchangeable



3. 308004TF EAN 4059709002002

Metall silberfarbig

Metal silver | Métal argenté
Incl. 2x LED-GU10 | 5W | 400lm
4.000K

4. 308005TF EAN 4059709002019

Metall anthrazit

Metal anthracite | Métal anthracite
Incl. 2x LED-GU10 | 5W | 400lm
4.000K



Dreh- und schwenkbares LED-Flächenlicht ist die perfekte Lösung für Ihren Außenbereich. Die extrem starke Leuchtkraft garantiert auch bei Dunkelheit einen sicheren Tritt.

Rotating and swivelling LED surface light is the perfect solution for your outdoor area. The extremely strong luminosity guarantees a safe step even in the dark.

Les luminaires LED en saillie rotatifs et pivotants est la solution parfaite pour votre espace extérieur. La forte luminosité garantit un pas sûr même dans l'obscurité.

GUT DURCHDACHTE LICHTIDEEN FÜR MEHR SICHERHEIT.

Well thought-out lighting ideas for greater security.

Des idées légères bien pensées pour plus de sécurité.

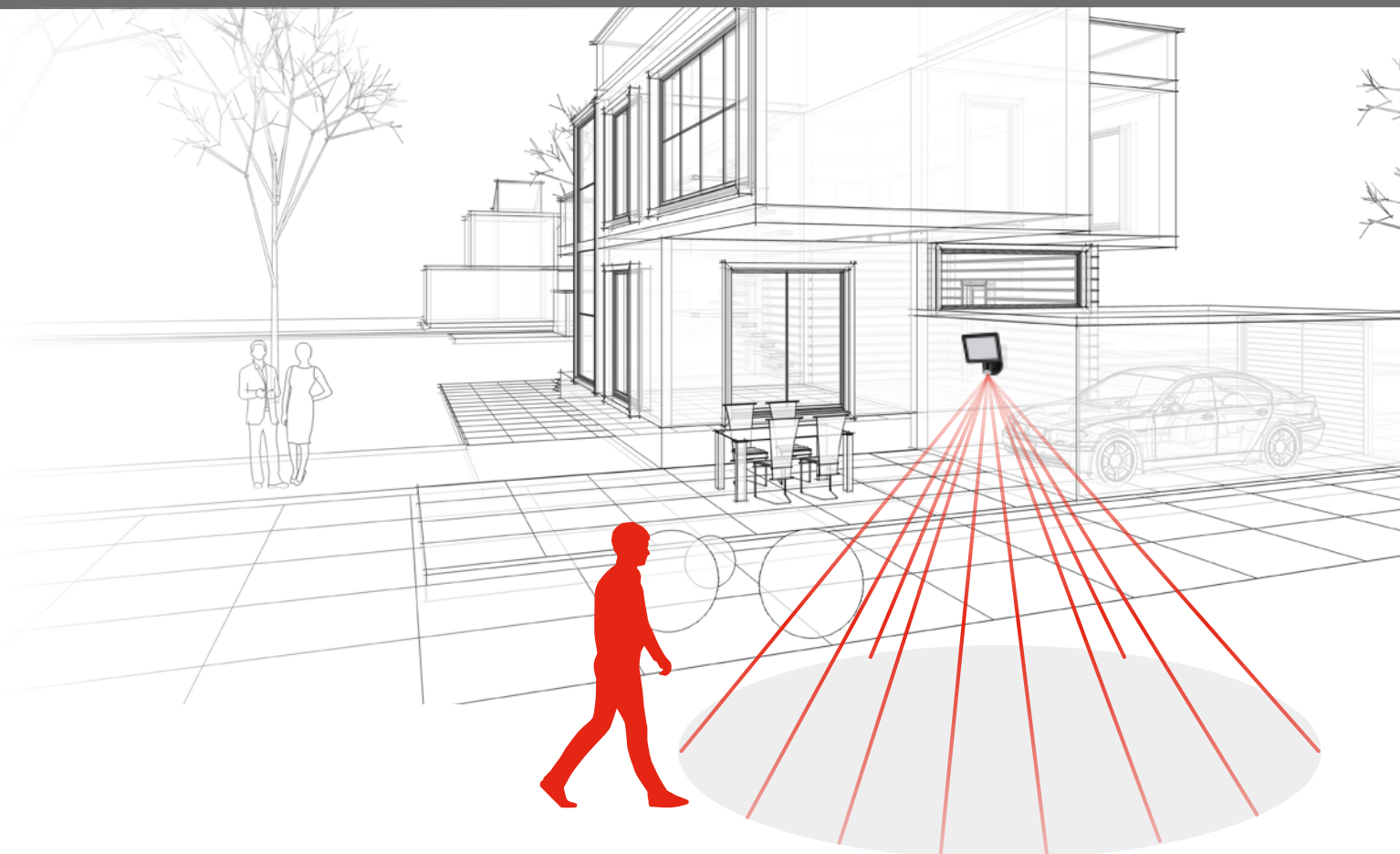

POINT OF SALE

Unser Beitrag für
eine grünere Zukunft:
Karton statt Blister!



TELEFUNKEN

INTELLIGENTE
BELEUCHTUNGSI
FÜR KOMFORT U
SICHERHEIT

RENOMMIERTE MAR
QUALITÄT RUND UM

- Modernste LED- & IR-T
- Lichtdesign der Zukunft
- Hochwertige, exklusive
- In Schwarz, Weiß & Silb
- Persönliche Hausnumm

DEEN
ND

TELEFUNKEN



TELEFUNKEN



TELEFUNKEN

Durchdachte Lichtlösungen für Ihre Sicherheit



- Klein- und punktförmige Leuchtmuster
- Keine Lichtblende
- Hohe Leuchtdichte über einen weiten Glanzwinkel
- Allwettertaugliches, ansprechendes Design



KEN-
S HAUS

Technik

t
Materialien
über erhältlich
herngestaltung



TECHNISCHE AUSSENLEUCHTEN

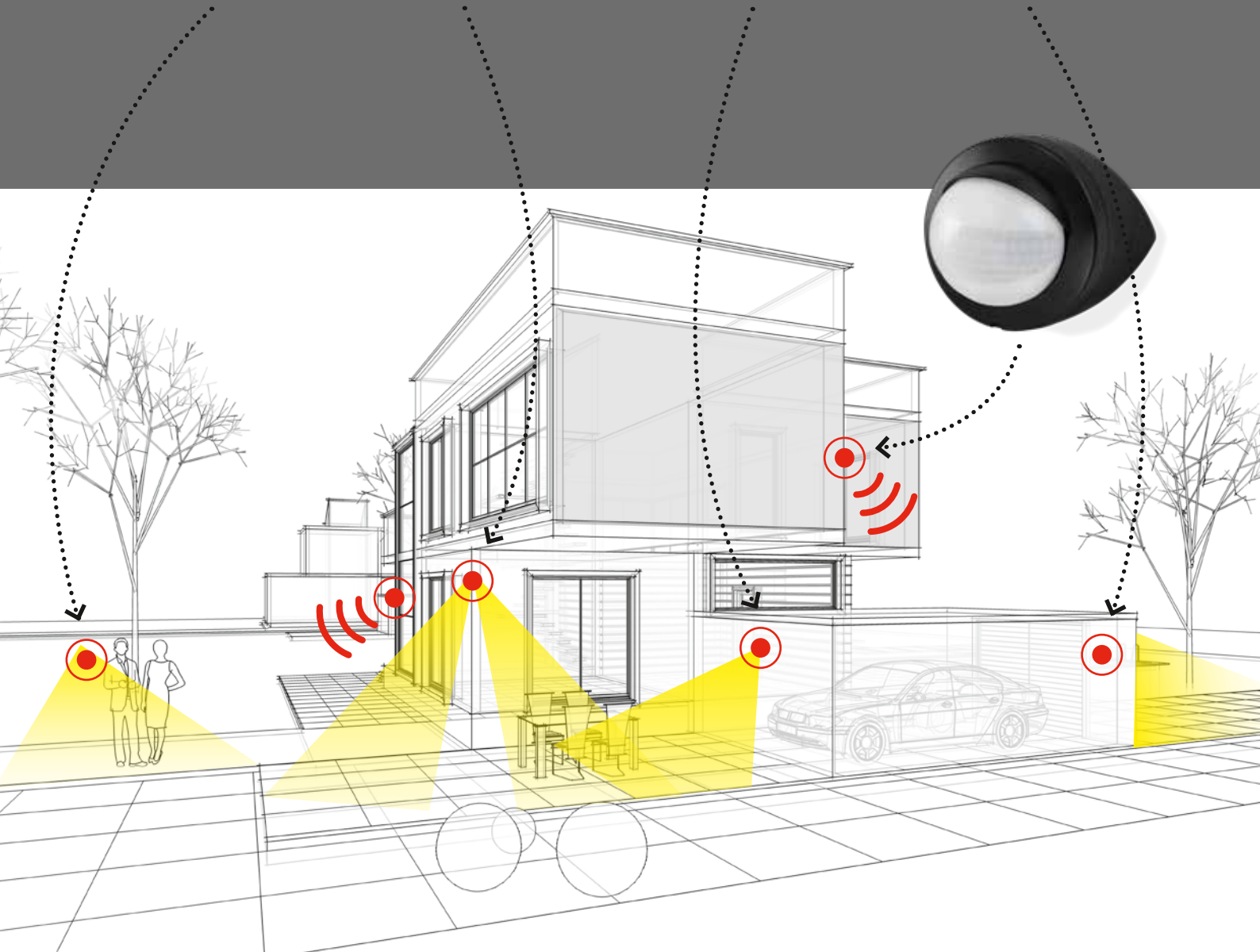

BELEUCHTUNGSDIEEN RUND UMS HAUS.

Lighting ideas around the house.

Des idées d'éclairage autour de la maison.

Manche Bereiche rund ums Haus sind besonders uneinsehbar. Für diese Bereiche empfehlen wir Außenleuchten, die mit extrem hellen LEDs ausgestattet sind.

Für eine gezielte Ausleuchtung eignen sich hier LED-Außenleuchten mit dreh- und schwenkbaren Leuchtkörpern. Auch Solarleuchten mit getrennt positionierbaren Solar-Panelen bieten interessante Möglichkeiten und schonen die Ressourcen. Natürlich steht bei unserem technischen Außenleuchtesortiment die Funktionalität im Vordergrund. Hier wurde hochwertige und durchdachte Technik in zeitlosen Gehäusen verbaut. Unauffällige Sicherheit rund ums Haus, Helligkeit für Flächen die sonst im Dunkeln bleiben. Ein Sortiment für alle, die auf Funktionalität und Sicherheit setzen.

Some areas around the house are particularly secluded. For these areas we recommend outdoor luminaires equipped with extremely bright LEDs.

LED outdoor lights with rotating and swivelling light bodies are suitable for targeted illumination. Solar lights with separately positionable solar panels also offer a wide range of possibilities and save resources. Naturally, functionality is the main focus of our technical outdoor lighting range. Here, high-quality and sophisticated technology were combined in timeless housings. Unobtrusive security around the house, brightness for areas that would otherwise remain in the dark. A range for all those who focus on functionality and safety.

Certaines zones autour de la maison sont particulièrement isolées. Pour ces zones, nous recommandons des luminaires extérieurs LED extrêmement puissants.

Les éclairages extérieurs LED rotatifs et pivotants conviennent ici pour un éclairage ciblé. Les luminaires solaires avec des panneaux solaires positionnable séparément offrent des possibilités intéressantes et permettent d'économiser des ressources. Naturellement, la fonctionnalité est le point central de notre gamme d'éclairage extérieur technique. Ici, une technologie de qualité accompagne un design intemporel. À une sécurité discrète tout autour de la maison s'ajoute un éclairage de zones qui resteraient sinon dans l'obscurité. Une gamme pour tous ceux qui se concentrent sur la fonctionnalité et la sécurité.

FLÄCHENLICHT

Surface light / Projecteurs

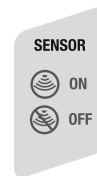

2



1-3 HIGHLIGHTS

1



3

- Inkl. Bewegungsmelder
- Sensor drehbar
- Reflektor schwenkbar
- Erfassungsbereich 3 - 12m
- Erfassungswinkel 150°
- Zeiteinstellung 5sek.-3min.
- Inkl. Dauerlichtfunktion
- Dämmerungssensor $\geq 10\text{lux}$
- Inkl. Verbindungsfunktion bis max. 100W

- Incl. motion detector
- Sensor rotatable
- Pivatable reflector
- Detection range 3 - 12m
- Detection angle 150°
- Time setting 5sec.-3min
- Incl. continuous light function
- Twilight sensor $\geq 10\text{lux}$
- Incl. connection function up to max. 100W

- Détecteur de mouvement incl.
- Capteur rotatif
- Réflecteur pivotant
- Champ de détection 3 - 12m
- Angle de détection 150°
- Réglage du temps 5sec.-3min.
- Avec fonction d'éclairage permanent
- Détecteur crépusculaire $\geq 10\text{lux}$
- Incl. fonction de raccordement jusqu'à max. 100W

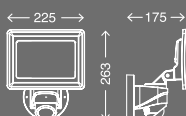

1. 304404TF EAN 4059709001159

Kunststoff silberfarbig

Plastic silver | Plastique argenté
Incl. 1x LED-Platine | 20W | 2.000lm
4.000K

2. 304405TF EAN 4059709001135

Kunststoff schwarz

Plastic black | Plastique noir
Incl. 1x LED-Platine | 20W | 2.000lm
4.000K

3. 304406TF EAN 4059709001142

Kunststoff weiß

Plastic white | Plastique blanc
Incl. 1x LED-Platine | 20W | 2.000lm
4.000K



LIGHTS WARNA

4-5 HIGH-LIGHTS

- Inkl. Bewegungsmelder
- Licht für große Flächen
- Sensor drehbar
- Reflektor schwenkbar
- Erfassungsbereich 5-12m
- Erfassungswinkel 180°
- Zeiteinstellung 3sek.-7min.
- Dämmerungssensor 10-2.000lux

- Incl. motion detector
- Light for large areas
- Sensor rotatable
- Pivotal reflector
- Detection range 5-12m
- Detection angle 180°
- Time setting 3sec.-7min.
- Twilight sensor 10-2.000lux

- Détecteur de mouvement incl.
- Éclairage de zones importantes
- Capteur rotatif
- Réflecteur pivotant
- Champ de détection 5-12m
- Angle de détection 180°
- Réglage du temps 3sec.-7min.
- Détecteur crépusculaire 10-2.000lux

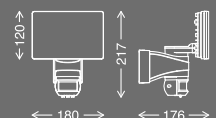

4. 315705TF EAN 4059709003832

Aluminium-Kunststoff schwarz

Aluminium plastic black | Aluminium-plastique noir
Incl. 1x LED-Platine | 20W | 2.300lm
4.000K

5. 315706TF EAN 4059709003825

Aluminium-Kunststoff weiß

Aluminium plastic white | Aluminium-plastique blanc
Incl. 1x LED-Platine | 20W | 2.300lm
4.000K

FLÄCHENLICHT

Surface light / Projecteurs

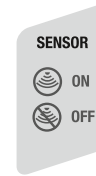

LIGHTS CRISTO



1 - 3 HIGHLIGHTS

- Inkl. Bewegungsmelder
- Sensor drehbar
- Reflektor schwenkbar
- Erfassungsbereich 3 - 12m
- Erfassungswinkel 150°
- Zeiteinstellung 5sek.-3min.
- Inkl. Dauerlichtfunktion
- Dämmerungssensor >10lux
- Inkl. Verbindungsfunktion bis max. 100W

- Incl. motion detector
- Sensor rotatable
- Pivotal reflector
- Detection range 3 - 12m
- Detection angle 150°
- Time setting 5sec.-3min
- Incl. continuous light function
- Twilight sensor >10lux
- Incl. connection function up to max. 100W

- Détecteur de mouvement incl.
- Capteur rotatif
- Réflecteur pivotant
- Champ de détection 3 - 12m
- Angle de détection 150°
- Réglage du temps 5sec.-3min.
- Avec fonction d'éclairage permanent
- Détecteur crépusculaire >10lux
- Incl. fonction de raccordement jusqu'à max. 100W

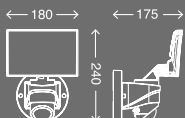

1. 304304TF EAN 4059709001128
Kunststoff silberfarbig
 Plastic silver | Plastique argenté
 Incl. 1x LED-Platine | 16W | 1.600lm
 4.000K

2. 304305TF EAN 4059709001111
Kunststoff schwarz
 Plastic black | Plastique noir
 Incl. 1x LED-Platine | 16W | 1.600lm
 4.000K

3. 304306TF EAN 4059709001104
Kunststoff weiß
 Plastic white | Plastique blanc
 Incl. 1x LED-Platine | 16W | 1.600lm
 4.000K



Miteinander koppelbar
Coupled with each other
Couplé l'un à l'autre



4



5



6

4-6 HIGH-LIGHTS

- Licht für große Flächen
- Reflektor schwenkbar
- Inkl. Verbindungsfunktion
- Light for large areas
- Reflector rotatable
- Incl. connection fonction
- Éclairage de zones importantes
- Pivotal reflector
- Incl. fonction de raccordement

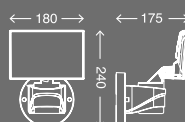

4. 304504TF EAN 4059709001180

Kunststoff silberfarbig

Plastic silver | Plastique argenté

Incl. 1x LED-Platine | 16W | 1.600lm
4.000K

5. 304505TF EAN 4059709001173

Kunststoff schwarz

Plastic black | Plastique noir

Incl. 1x LED-Platine | 16W | 1.600lm
4.000K

6. 304506TF EAN 4059709001166

Kunststoff weiß

Plastic white | Plastique blanc

Incl. 1x LED-Platine | 16W | 1.600lm
4.000K

FLÄCHENLICHT

Surface light / Projecteurs



1

LIGHTS
BILBAO

1-2 HIGH-LIGHTS

- Inkl. Bewegungsmelder
- Sensor drehbar
- Reflektor schwenkbar
- Erfassungsbereich 3 - 12m
- Erfassungswinkel 150°
- Zeiteinstellung 5sek.-3min.
- Inkl. Dauerlichtfunktion
- Dämmerungssensor >10lux
- Inkl. Verbindungsfunktion bis max. 100W



2

- Incl. motion detector
- Sensor rotatable
- Pivatable reflector
- Detection range 3 - 12m
- Detection angle 150°
- Time setting 5sec.-3min
- Incl. continuous light function
- Twilight sensor >10lux
- Incl. connection function up to max. 100W

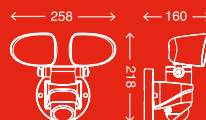

- Détecteur de mouvement incl.
- Capteur rotatif
- Réflecteur pivotant
- Champ de détection 3 - 12m
- Angle de détection 150°
- Réglage du temps 5sec.-3min
- Avec fonction d'éclairage permanent
- Détecteur crépusculaire >10lux
- Incl. fonction de raccordement jusqu'à max. 100W

1. 304605TF EAN 4059709001203

Kunststoff schwarz

Plastic black | Plastique noir

Incl. 2x LED-Platine | 2x10W | 2x1.000lm

4.000K

2. 304606TF EAN 4059709001197

Kunststoff weiß

Plastic white | Plastique blanc

Incl. 2x LED-Platine | 2x10W | 2x1.000lm

4.000K



3-4 HIGH-LIGHTS

- Inkl. Bewegungsmelder
- Sensor drehbar
- Reflektor schwenkbar
- Erfassungsbereich max. 12m
- Erfassungswinkel 110°
- Zeiteinstellung 10sek.-1min.
- Inkl. Dauerlichtfunktion
- Dämmerungssensor 5 - 50.000lux

- Incl. motion detector
- Sensor rotatable
- Pivotal reflector
- Detection range max. 12m
- Detection angle 110°
- Time setting 10sec.-1min.
- Incl. continuous light function
- Twilight sensor 5 - 50.000lux

- Détecteur de mouvement incl.
- Capteur rotatif
- Réflecteur pivotant
- Réglage du temps 10sec.-1min.
- Champ de détection max. 12m
- Angle de détection 110°
- Avec fonction d'éclairage permanent
- Détecteur crépusculaire 5 - 50.000lux



4

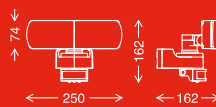

3. 315105TF EAN 4059709003665

Kunststoff-Metall schwarz

Plastic-metal black | Plastique-métal noir
Incl. 2x LED-Platine | 2x15W | 2x1.550lm
4.000K

4. 315106TF EAN 4059709003672

Kunststoff-Metall weiß

Plastic-metal white | Plastique-métal blanc
Incl. 2x LED-Platine | 2x15W | 2x1.550lm
4.000K

VERSTECKTER SENSOR

Hidden sensor / Capteur caché



LIGHTS
DORTMUND

1

2

3

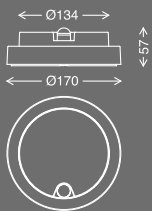

1 - 3 HIGHLIGHTS

- Inkl. Bewegungsmelder
 - Erfassungsbereich max. 8m
 - Erfassungswinkel 100°
 - Zeiteinstellung 75sek.
 - Dämmerungssensor 5 - 25lux
- Incl. motion detector
 - Detection range max. 8m
 - Detection angle 100°
 - Time setting 75sec.
 - Twilight sensor 5 - 25lux
- Détecteur de mouvement incl.
 - Champ de détection 8m max.
 - Angle de détection 100°
 - Réglage du temps 75sec.
 - Détecteur crépusculaire 5 - 25lux

1. 315304TF EAN 4059709003733

Kunststoff silberfarbig

Plastic silver | Plastique argenté
Incl. 1x LED-Platine | 12W | 1.150lm
4.000K

2. 315305TF EAN 4059709003719

Kunststoff schwarz

Plastic black | Plastique noir
Incl. 1x LED-Platine | 12W | 1.150lm
4.000K

3. 315306TF EAN 4059709003726

Kunststoff weiß

Plastic white | Plastique blanc
Incl. 1x LED-Platine | 12W | 1.150lm
4.000K

ZUBEHÖR

Accessories / Accessoires



EQUIPMENT
POSEN

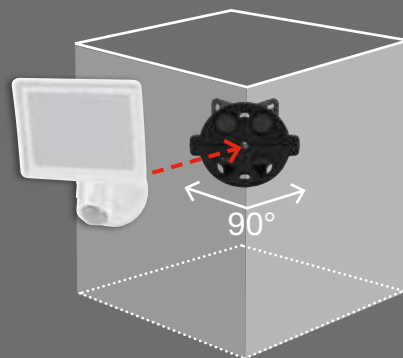

Adapter für Eckmontage

Adapter for corner mounting

Adaptateur pour fixation en coin

4-5 HIGHLIGHTS

- Adapter zur Befestigung von Leuchten an Ecken von Häusern, Garagen etc.
- Adapter for attachment for lamps at corners of houses, garages etc.
- Adaptateur pour fixation pour coins des maisons, des garages, etc.



4

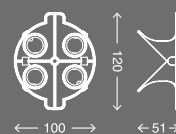

4. 306105TF EAN 4059709001524

Adapter schwarz | Adapter black | Adaptateur noir

Suitable for the following lights:

304306TF, 304305TF, 304304TF, 304405TF, 304406TF, 304404TF,
304506TF, 304504TF, 304505TF, 304606TF, 304605TF

SENSOREN

Sensor / Capteur

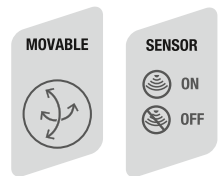

EQUIPMENT MONACO

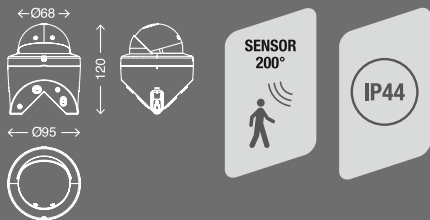

EQUIPMENT SKOPJE

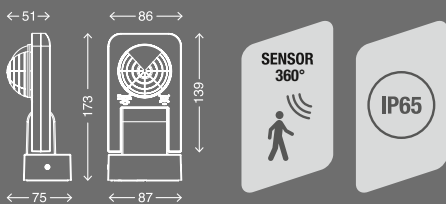

No.	Article-No.	reach	coverage angle	time setting	incl. perm. light	max. Load	EAN
1.	305905TF	max. 12m	200°	3sec - 30min	x	max. 1.000W AGL / 100W LED	4059709001371
2.	305906TF	max. 12m	200°	3sec - 30min	x	max. 1.000W AGL / 100W LED	4059709001364
3.	309205TF	max. 20m	360°	10sec - 30min	x	max. 2.000W AGL / 500W LED	4059709002279
4.	309206TF	max. 20m	360°	10sec - 30min	x	max. 2.000W AGL / 500W LED	4059709002262

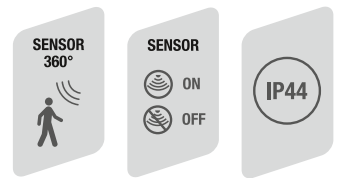

5



EQUIPMENT
JENA

6

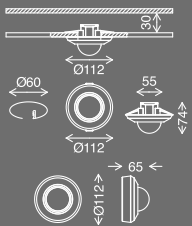

1-6 HIGHLIGHTS

- Bewegungsmelder für Außenleuchten
- Separat von der Leuchte einsetzbar
- Inkl. Zeiteinstellung
- Inkl. Dauerlichtfunktion
- Dämmerungssensor 3 - 2.000lux
- Kunststoff schwarz oder weiß

- Motion detector for outdoor lamps
- Can be used separately from the luminaire
- Incl. time setting
- Incl. continuous light function
- Twilight sensor 3 - 2.000lux
- Plastic black or white

- Détecteur de mouvement pour luminaire extérieur
- Peut être utilisé séparément du luminaire
- Réglage du temps incl.
- Twilight sensor 3 - 2.000lux
- Avec fonction d'éclairage permanent
- Détecteur crépusculaire 3 - 2.000lux
- Plastique noir ou blanc



No.	Article-No.	reach	coverage angle	time setting	incl. perm. light	max. Load	EAN
5.	314705TF	max. 20m	360°	10sec - 30min	x	max. 2.000W AGL / 1.000W LED	4059709003603
6.	314706TF	max. 20m	360°	10sec - 30min	x	max. 2.000W AGL / 1.000W LED	4059709003597

SENSOREN

Sensor / Capteur

EQUIPMENT
CORK

1



2



3

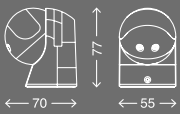

1-6 HIGHLIGHTS

- Bewegungsmelder
- Inkl. Zeiteinstellung 10sek.-7min.
- Dämmerungssensor 10-2.000lux
- Kunststoff silberfarbig, schwarz o. weiß

- Motion detector
- Incl. time setting 10sec.-7min.
- Twilight sensor 10-2.000lux
- Plastic silver, black or white

- Détecteur de mouvement
- Réglage du temps incl. 10sec.-7min.
- Détecteur crépusculaire 10-2.000lux
- Plastique argenté, noir ou blanc

No.	Article-No.	reach	coverage angle	time setting	incl. perm. light	max. Load	EAN
1.	306404TF	max. 12m	180°	10sec - 7min	-	max. 2.000W AGL / 1.000W LED	4059709001685
2.	306405TF	max. 12m	180°	10sec - 7min	-	max. 2.000W AGL / 1.000W LED	4059709001609
3.	306406TF	max. 12m	180°	10sec - 7min	-	max. 2.000W AGL / 1.000W LED	4059709001593

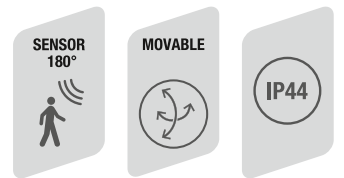

4



EQUIPMENT FUNCHAL

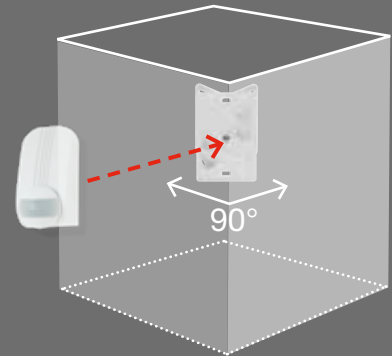

Inkl. Adapter für Eckmontage

Incl. Adapter for corner mounting

incl. adaptateur pour fixation en coin

5



6

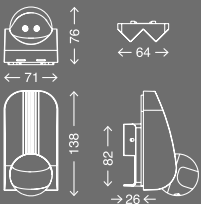

No.	Article-No.	reach	coverage angle	time setting	incl. perm. light	max. Load	EAN
4.	306504TF	0-max.12m	180°	10sec - 7min	-	max. 2.000W AGL / 1.000W LED	4059709001852
5.	306505TF	0-max.12m	180°	10sec - 7min	-	max. 2.000W AGL / 1.000W LED	4059709001869
6.	306506TF	0-max.12m	180°	10sec - 7min	-	max. 2.000W AGL / 1.000W LED	4059709001876

SOLARLEUCHTEN

Solar outdoor lamp / Luminaire extérieur solaire

LIGHTS
KIRUNA

1



2



3

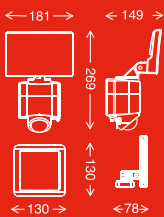

HQ
LED
20.000h

SENSOR
150°



SOLAR



MOVABLE



IP44

1-3 HIGHLIGHTS

- Sensor drehbar
- Reflektor schwenkbar
- Erfassungsbereich 3 - 12m
- Erfassungswinkel 150°
- Zeiteinstellung 5sek.-3min.
- Dämmerungssensor ≤35lux
- Inkl. Solar 6V Panel, Kabellänge 5m
- Funktionszeit 2h
- Inkl. 1x Batterie 3,7V; 2.000mAh

- Sensor rotatable
- Pivotal reflector
- Detection range 3 - 12m
- Detection angle 150°
- Time setting 5sec.-3min.
- Twilight sensor ≤35lux
- Incl. 6V LED-board, cable length 5m
- Function time 2h
- Incl. 1x battery 3,7V; 2.000mAh

- Capteur rotatif
- Réflecteur pivotant
- Champ de détection 3 - 12m
- Angle de détection 150°
- Réglage du temps 5sec.-3min.
- Détecteur crépusculaire ≤35lux
- Incl. 6V panneau solaire, longueur de câble 5m
- Durée de fonctionnement 2h
- Incl. 1x pile 3,7V; 2.000mAh

1. 304704TF EAN 4059709001234

Kunststoff silberfarbig

Plastic silver | Plastique argenté
Incl. 1x LED-Platine | 6W | 400lm
4.000K

2. 304705TF EAN 4059709001227

Kunststoff schwarz

Plastic black | Plastique noir
Incl. 1x LED-Platine | 6W | 400lm
4.000K

3. 304706TF EAN 4059709001210

Kunststoff weiß

Plastic white | Plastique blanc
Incl. 1x LED-Platine | 6W | 400lm
4.000K

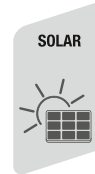
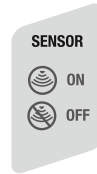

LIGHTS METZ

4-6 HIGH-LIGHTS

- Reflektor und Solarpanel schwenkbar
- Erfassungsbereich 6 - 8m
- Erfassungswinkel 100°
- Dämmerungssensor <150lux
- Inkl. Solar 5,5V Panel
- Inkl. Schalter OFF-ON-PIR; ON (Dauerlicht)
- Funktionszeit 8h
- Inkl. 1x Batterie 3,7V; 2.000mAh

- Reflector and solar panel pivotable
- Detection range 6 - 8m
- Detection angle 100°
- Twilight sensor <150lux
- Incl. 5,5V LED-board
- Incl. conmutador OFF-ON-PIR; ON (continuous light)
- Function time 8h
- Incl. 1x battery 3,7V; 2.000mAh

- Réflecteur et panneau solaire pivotant
- Champ de détection 6-8m
- Angle de détection 100°
- Détecteur crépusculaire <150lux
- Incl. 5,5V panneau solaire
- Incl. interrupteur OFF-ON-PIR; ON (éclairage continu)
- Durée de fonctionnement 8h
- Incl. 1x pile 3,7V; 2.000mAh

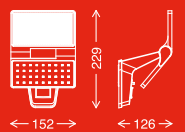

4. 315204TF EAN 4059709003689
Kunststoff silberfarbig
 Plastic silver | Plastique argenté
 Incl. 1x LED-Platine | 3W | 420lm
 4.000K

5. 315205TF EAN 4059709003696
Kunststoff schwarz
 Plastic black | Plastique noir
 Incl. 1x LED-Platine | 3W | 420lm
 4.000K

6. 315206TF EAN 4059709003702
Kunststoff weiß
 Plastic white | Plastique blanc
 Incl. 1x LED-Platine | 3W | 420lm
 4.000K

SOLARLEUCHTEN

Solar outdoor lamp / Luminaire extérieur solaire

EQUIPMENT
OULU

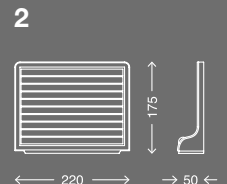
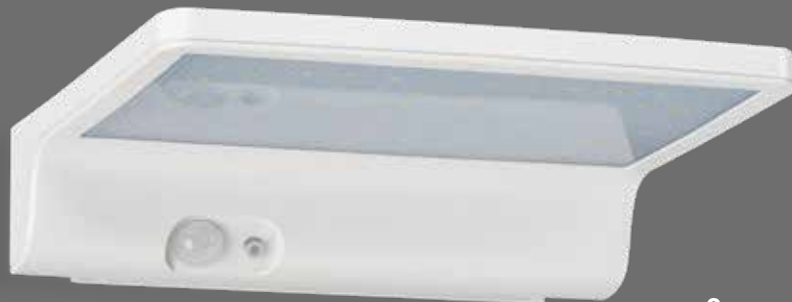
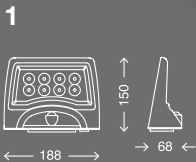

1 HIGH-LIGHTS

- Inkl. Solarpanel 5,4V
- Inkl. 1x Batterie 3,7V; 1.300 mAh
- Inkl. Bewegungsmelder
- Erfassungsbereich 5 - 8m
- Erfassungswinkel 90°
- Zeiteinstellung 30sek.
- Inkl. Dämmerungssensor <100lux

- Incl. solar panel 5,4V
- Incl. 1x battery 3,7V; 1.300 mAh
- Incl. motion detector
- Detection range 5 - 8m
- Detection angle 90°
- Time setting 30sec.
- Twilight sensor <100lux

- Panneau solaire 5,4V incl.
- Incl. 1x pile 3,7V; 1.300 mAh
- Détecteur de mouvement incl.
- Champ de détection 5 - 8m
- Angle de détection 90°
- Réglage du temps 30sec.
- Détecteur crépusculaire <100lux

1. 304806TF EAN 4059709001241

Kunststoff weiß

Plastic white | Plastique blanc
Incl. 1x LED-Platine | 300lm
4.000K

2. 304906TF EAN 4059709001258

Kunststoff weiß

Plastic white | Plastique blanc
Incl. 1x LED-Platine | 500lm
4.000K

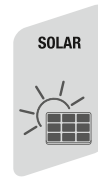

2 HIGHLIGHTS

- Inkl. Solarpanel 9,6V
- Inkl. 1x Batterie 7,4V; 2.000 mAh
- Inkl. Bewegungsmelder
- Erfassungsbereich 5 - 8m
- Erfassungswinkel 90°
- Zeiteinstellung 30sek.
- Inkl. Dämmerungssensor <100lux

- Incl. solar panel 5,4V
- Incl. 1x battery 3,7V; 1.300 mAh
- Incl. motion detector
- Detection range 5 - 8m
- Detection angle 90°
- Time setting 30sec.
- Twilight sensor <100lux

- Panneau solaire 5,4V incl.
- Incl. 1x pile 3,7V; 1.300 mAh
- Détecteur de mouvement incl.
- Champ de détection 5 - 8m
- Angle de détection 90°
- Réglage du temps 30sec.
- Détecteur crépusculaire <100lux

POINT OF SALE

Durch eine klare und intuitiv zu verstehende POS-Konzeption, welche die vielseitigen Einsatzmöglichkeiten unserer Leuchten, sowie die einfachen Montagemöglichkeiten selbsterklärend vermittelt, wird der Kunde in seiner Kaufentscheidung optimal unterstützt.

Wir bieten mit der Marke TELEFUNKEN einen einfachen Zugang zu modernen LED-Lichtlösungen, die durch ihre intelligenten Funktionen das Zuhause heller, komfortabler und sicherer machen. TELEFUNKEN – Intelligente Lichtlösungen für ein modernes Zuhause.

Our clear and easy-to-understand POS concept supports customers in making their purchase decisions by explaining the versatile ways in which our lights can be used, as well as their simple mounting options.

Through the TELEFUNKEN brand, we offer an easy way into the world of modern LED lighting solutions. Their smart functions make homes brighter, safer and more comfortable. TELEFUNKEN – Smart lighting solutions for the modern home.

Grâce à la conception claire et intuitive de notre point de vente, qui reflète les options d'utilisation multiples de nos lampes et leur simplicité de montage, le client sera accompagné de manière optimale dans sa décision d'achat.

Avec la marque TELEFUNKEN, nous vous proposons d'accéder directement à des solutions d'éclairage LED modernes, qui rendent l'habitat plus lumineux, plus agréable et plus sûr grâce à leurs fonctions intelligentes. TELEFUNKEN – Des solutions d'éclairage intelligentes pour un intérieur moderne.





Herstellergarantie der HVMM Licht GmbH & Co. KG, Im Kissen 2, 59929 Brilon, Deutschland

Wir, die HVMM Licht GmbH & Co. KG, gewähren allen Endkunden eine unentgeltliche Herstellergarantie gemäß den nachstehenden Bedingungen:

Wir leisten Garantie durch kostenlose Behebung der Mängel (nach unserer Wahl: Reparatur, Austausch ggf. durch ein Nachfolgemodell oder Rückerstattung des Kaufpreises), die innerhalb der Garantiezeit auf einem Material- oder Herstellungsfehler beruhen. Unsere Herstellergarantie gilt nicht für die auswechselbaren Leuchtmittel und bei nicht bestimmungs- oder unsachgemäßem Gebrauch.

Unsere Herstellergarantie lässt Ihre gesetzlichen Rechte, die Ihnen als Verbraucher gegenüber dem Verkäufer nach geltendem Recht einschließlich besonderer Schutzbestimmungen für Verbraucher zustehen können, unberührt. Unsere hier beschriebenen Leistungen gelten zusätzlich zu den gesetzlichen Rechten und beschränken oder ersetzen diese nicht.

Die Garantiezeit beträgt 2 bzw. 5 Jahre. Maßgeblich ist der Zeitraum, der auf der jeweiligen Verpackung des Produkts vermerkt ist. Die Garantiezeit beginnt mit dem Kaufdatum. Die Garantie gilt für sämtliche HVMM Licht Produkte, die in der EU gekauft und verwendet werden.

Setzen Sie sich bitte im Garantiefall (mündlich oder in Textform) mit dem Händler oder Vertragspartner, bei dem Sie die Leuchte gekauft haben, in Verbindung und machen Sie Ihren Garantieanspruch unter Vorlage des Kaufbelegs geltend.

Diese Bedingungen unserer Herstellergarantie finden Sie auch unter www.hvmm-licht.com/herstellergarantie

Manufacturer's Warranty, HVMM Licht GmbH & Co. KG, Im Kissen 2, 59929 Brilon, Deutschland

We, HVMM Licht GmbH & Co. KG, grant all end customers a Manufacturer's Warranty that is free of charge, according to the following conditions:

The warranty shall be fulfilled through the cost-free rectification of defects (according to our choice: repair, replacement, if necessary by a newer model, or repayment of sales price) based on material or manufacturing errors, within the warranty period. Our Manufacturer's Warranty shall not apply for replaceable light bulbs, or for damage caused due to improper use or use other than the intended use.

Our Manufacturer's Warranty does not affect the statutory rights that can be asserted by the consumer against the seller according to applicable law, including particular safeguarding provisions for consumers. The services provided by us that are described here apply in addition to statutory rights and do not restrict or replace these.

The warranty period is either 2 or 5 years. The time period that is stated on the packaging of the relevant product is authoritative. The warranty period begins on the date of purchase. The warranty applies for all HVMM Licht products that are sold and used in the EU.

In the case of a warranty claim, please get in touch (verbally or in writing) with the trader or contractual party from whom you purchased the light, and assert your warranty claim with a copy of your proof of purchase.

You can also download these Manufacturer's Warranty conditions at www.hvmm-licht.com/herstellergarantie

Garantie de fabricant de la société HVMM Licht GmbH & Co. KG, Im Kissen 2, 59929 Brilon, Allemagne

Nous, la société HVMM Licht GmbH & Co. KG, accordons à tous les clients finaux une garantie de fabricant gratuite conformément aux conditions suivantes:

Notre prestation de garantie comprend la correction gratuite des défauts (selon notre choix : réparation, remplacement le cas échéant par un modèle plus récent ou remboursement du prix d'achat) reposant sur un défaut de matériau ou de fabrication dans le délai de garantie. Notre garantie de fabricant n'est pas valable pour les ampoules interchangeables ainsi que dans le cas d'une utilisation non conforme ou abusive.

Notre garantie de fabricant ne change en rien les droits légaux auxquels vous pouvez prétendre en tant que consommateur vis à vis du revendeur, ceci selon la législation en vigueur et en incluant les dispositions de protection particulières destinées aux consommateurs. Nos prestations décrites ici sont valables en plus des droits légaux. Elles n'ont pas vocation à les limiter ou les remplacer.

Le délai de garantie est de 2 voire 5 ans. La période à prendre en compte est celle indiquée sur l'emballage respectif du produit. Le délai de garantie est valable à partir de la date d'achat. La garantie s'applique à tous les luminaires HVMM achetés et utilisés en UE.

En cas de recours à la garantie (oralement ou par écrit), veuillez contacter le revendeur ou le partenaire contractuel auprès duquel vous avez acheté le luminaire et faites valoir votre droit de garantie en présentant le reçu de caisse.

Ces conditions de notre garantie de fabricant peuvent être également téléchargées en allant sur www.hvmm-licht.com/herstellergarantie

Mit dem Erscheinen dieses Kataloges, verlieren der vorhergehende Katalog und alle anderen Kataloge und Preislisten ihre Gültigkeit. Alle Angaben in diesem Katalog sind unverbindlich. Wir möchten, dass Sie alle Produkte auf dem neuesten Stand der Technik erhalten. Deshalb erlauben wir uns, immer dann etwas zu verändern, wenn es für die Leuchten von Vorteil ist. Für alle Lieferungen gelten unsere aktuellen Verkaufs- und Lieferbedingungen.

Upon publication of this catalog, the previous catalog and all other catalogs and price lists cease to apply. All information provided in this catalog is non-binding and subject to change. We want you to receive all products at the latest state of the art, so we take the liberty of making changes wherever these changes are beneficial to the lamps. Our current terms and conditions of sale and delivery apply to all deliveries.

Avec la publication de ce catalogue, le catalogue précédent et tous les autres catalogues et listes de prix perdent leur validité. Toutes les indications figurant dans ce catalogue sont fournies sans engagement. Nous souhaitons vous proposer tous les produits au niveau le plus actuel de la technique. C'est pourquoi, nous nous permettons toujours de procéder à des modifications si celles-ci présentent un avantage pour les luminaires. Nos conditions générales de ventes et de livraison actuelles s'appliquent à toutes les livraisons.

SYMBOLE

Signs and Symbols / Légende



Hochleistungs-LED
High performance LED
Haute performance led

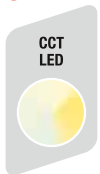

Weißtonmanagement CCT
White tone management
Contrôle des tonalités blanches



Farbtonmanagement RGB
Colour change management
Contrôle des couleurs



RGB-Magic-Lichteffekt
RGB magic light effect
Effect lumineux RGB magique



Innenlicht RGB-Magic
Inside light RGB magic
Lumière intérieure RGB magique



Außenlicht RGB
Exterior light RGB
Éclairage externe RGB



Backlighteffekt
Backlight effect
Effet de rétroéclairage



Infrarot-Sensor
Infrared sensor
infrarouge infrarouge



Microwellen-Sensor
Microwave sensor
Capteur crépusculaire et de mouvement



IR-Bewegungsmelder
IR-sensor
IR-capteur

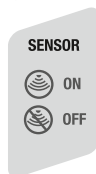

Override-funktion (Dauerlicht schaltbar)
Override function (continuous light switchable)
Fonction Override (commande d'éclairage permanent)



Timer
Timer
Minuteur



Memory-Funktion
Memory function
Fonction mémoire

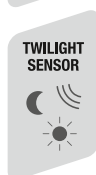

Dämmerungssensor
Twilight sensor
Capteur crépusculaire



Sternendekor
Star decor
Décor ciel étoilé



Dimmbar via Fernbedienung
Dimmable via remote control
Dimmable par télécommande

DIMMABLE
IN STEPS



Stufendimmbar

Step dimmer

Dimmable par niveau de luminosité

IP44

IP-Schutzart

IP-rating

IP = Indice de protection

SOLAR



Solarpanel inklusive

Solar panel

Panneau solaire

MOVABLE



Schwenkbar

Pivotable

Orientable

STUFEN-
SCHALTER



Stufenschalter

Step switch

Interrupteur à paliers

ON-/OFF-
SWITCH



Wippschalter

Rocker switch

Interrupteur à bascule



ARTIKELVERZEICHNIS

Product directory / Index produits

ARTIKEL-NR. ART-NO. / NO ART.	SEITE PAGE	ARTIKEL-NR. ART-NO. / NO ART.	SEITE PAGE	ARTIKEL-NR. ART-NO. / NO ART.	SEITE PAGE	ARTIKEL-NR. ART-NO. / NO ART.	SEITE PAGE
200106TF	43	203004TF	33	205506TF	57	306504TF	141
200206TF	43	203104TF	34	205606TF	57	306505TF	141
200306TF	42	203204TF	34	303404TF	120	306506TF	141
200406TF	42	203306TF	62	303405TF	120	307005TF	121
200506TF	64	203406TF	62	303406TF	120	307104TF	122
200606TF	64	203506TF	48	304304TF	132	307106TF	122
200704TF	50	203609TF	49	304305TF	132	308004TF	123
200706TF	50	203704TF	47	304306TF	132	308005TF	123
201106TF	40	203804TF	47	304404TF	130	308606TF	76
201206TF	40	203904TF	47	304405TF	130	308706TF	76
201306TF	40	204006TF	45	304406TF	130	309004TF	77
201404TF	35	204106TF	45	304504TF	133	309205TF	138
201504TF	35	204204TF	37	304505TF	133	309206TF	138
201604TF	35	204304TF	37	304506TF	133	311305TF	107
201706TF	67	204406TF	44	304605TF	134	311306TF	106
201806TF	67	204506TF	44	304606TF	134	311405TF	107
201906TF	67	204606TF	44	304704TF	142	311406TF	106
202006TF	52	204706TF	63	304705TF	142	311505TF	107
202106TF	52	204806TF	63	304706TF	142	311506TF	106
202206TF	65	204906TF	41	304806TF	144	311604TF	108
202306TF	65	205009TF	49	304906TF	144	311605TF	108
202406TF	65	205104TF	36	305905TF	138	312005TF	119
202506TF	56	205106TF	36	305906TF	138	312204TF	109
202606TF	56	205205TF	69	306105TF	137	312205TF	109
202706TF	32	205206TF	69	306404TF	140	312505TF	112
202806TF	32	205306TF	59	306405TF	140	312605TF	110
202904TF	33	205406TF	59	306406TF	140	312606TF	110

ARTIKEL-NR. ART-NO. / NO ART.	SEITE PAGE	ARTIKEL-NR. ART-NO. / NO ART.	SEITE PAGE	ARTIKEL-NR. ART-NO. / NO ART.	SEITE PAGE	ARTIKEL-NR. ART-NO. / NO ART.	SEITE PAGE
312704TF	118	314705TF	139	318806TF	21	320904TF	94
312705TF	118	314706TF	139	318906TF	20	320905TF	94
312805TF	118	314800TF	101	319006TF	22	321004TF	92
313004TF	96	314800TF	103	319106TF	22	321005TF	92
313005TF	96	314800TF	105	319206TF	23	321104TF	93
313104TF	97	315105TF	135	319306TF	23	321105TF	93
313105TF	97	315106TF	135	319405TF	17	600104TF	39
313204TF	98	315204TF	143	319406TF	18	600106TF	39
313205TF	98	315205TF	143	319505TF	17	600306TF	66
313304TF	99	315206TF	143	319506TF	18	600406TF	66
313305TF	99	315304TF	136	319605TF	16	600506TF	66
313405TF	100	315305TF	136	319606TF	19	600606TF	51
313406TF	100	315306TF	136	319704TF	11	600706TF	51
313505TF	102	315505TF	112	319804TF	11	601206TF	53
313506TF	102	315506TF	112	319904TF	12	601306TF	53
313604TF	104	315605TF	113	320004TF	10	601506TF	78
313605TF	104	315606TF	113	320104TF	12	601604TF	78
313705TF	101	315705TF	131	320204TF	95	601706TF	80
313706TF	101	315706TF	131	320205TF	95	601806TF	80
313805TF	103	315805TF	100	320206TF	95	601906TF	81
313806TF	103	315905TF	102	320304TF	117	602006TF	82
313904TF	105	318305TF	83	320305TF	117	602806TF	14
313905TF	105	318405TF	79	320404TF	114		
314405TF	111	318408TF	79	320405TF	114		
314406TF	111	318508TF	84	320504TF			
314502TF	119	318608TF	85	320505TF	115		
314505TF	119	318706TF	21	320506TF	115		

NOTIZEN

Notes

A series of 15 red square bullet points on the left side of the page, each followed by a set of horizontal lines for writing notes.



AULIX lighting

návrhy osvětlení a prodej svítidel
inteligentní systémy, vypínače

SVĚTELNÉ STUDIO

Náměstí Na Sádkách 705
252 41 Dolní Břežany (Praha západ)

Telefon: +420 246 083 152

Mobil.: +420 702 061 783

E-mail: studio@aulix.cz

Web: www.aulix.cz

E-shop: <http://obchod.aulix.cz>

Sledujte nás také na sociálních sítích:





LIGHT2022