

BROKIS® CATALOGUE

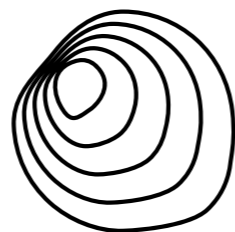

AULIX

WE LIVE FOR LIGHTING

SVĚTELNÉ STUDIO

Náměstí Na Sádkách 705
252 41 Dolní Břežany (Praha západ)

Telefon: +420 246 083 152
Mobil.: +420 702 061 783
E-mail: studio@aulix.cz
Web: www.aulix.cz

Sledujte nás také na sociálních sítích:



A TRADITIONALLY CRAFTED
CONTEMPORARY VISION OF LIGHT

BROKIS®

PRESERVING THE BOHEMIAN GLASSBLOWING TRADITION



BROKIS – a synthesis of exquisite design, superior quality, and the skill of master artisans continuing the centuries-old Bohemian glassmaking tradition. BROKIS lighting collections have achieved international acclaim by combining handblown glass with other refined materials, such as handcrafted wood and metal, in bold compositions that push the boundaries not only of contemporary lighting design but of the technologies applied in production. The family-run premium brand works with select designers from around the world and operates its own historical glassworks southeast of Prague.

BROKIS is the brainchild of successful Czech entrepreneur Jan Rabell. In 2006, he founded the brand as a platform to revitalize and elevate Bohemian glassmaking to new heights and preserve generations of knowledge and craftsmanship. Nearly ten years prior, in 1997, he acquired the ailing Janštejn Glassworks, which was established at the start of the 19th century approximately 140 kilometres southeast of Prague.

Demand for traditional products had declined significantly, many of the glassmakers were growing old and leaving, and time-honoured technologies and techniques were at risk of being lost. Mr. Rabell's vision was to restore the factory to its former prestige and ensure that the ages-old Bohemian glassmaking tradition endured into the 21st century.

With BROKIS, Jan Rabell created a lighting brand offering entirely different products than those previously produced at Janštejn Glassworks. Several new Italian-style furnaces were built, and production techniques were refined. Some, such as grinding and glass painting, were discontinued, and others were revived, like glassblowing using optic moulds and traditional hotshop techniques. Original and

nearly forgotten formulas for manufacturing coloured glass were reinstated and are now characteristic of the BROKIS brand. Therefore, it brings us great joy that in 2023 Czech handmade glass was inscribed in UNESCO's Representative List of the Intangible Cultural Heritage of Humanity.

BROKIS has firmly established itself as a leading innovator in glass lighting. For example, the complex technology applied in manufacturing the Night Birds collection, which consists of imposing yet elegant curved glass silhouettes of birds in various phases of flight, required two years of experimentation to perfect.

BROKIS is constantly developing new technologies for its lights in order to offer consistent industry-leading quality and innovation throughout its global product portfolio, such as with a special original connector, the sustainable material called BROKISGLASS, and TRIMLESS, a sleek new system for hanging pendent lights from lowered drywall ceilings. BROKIS has also recently developed a series of configurators for some of its most popular collections. These powerful online tools let customers create their very own bespoke lighting compositions in a user-friendly, intuitive interface.

BROKIS also maintains a strong online presence through a series of innovative initiatives, such as BROKIS VIRTUAL PROJECTS and the unique MyBrokis application. In January of 2022, BROKIS launched a website within Janštejn Glass Group (JGG). Today, BROKIS and Janštejn Glassworks employ more than 100 people and enjoy a unique symbiosis that has allowed BROKIS to establish sales operations in 120 countries and regularly showcase its renowned lighting collections at the world's top design shows.



JAN RABELL

“NOTHING’S IMPOSSIBLE;
NEVER SAY IT CAN’T
BE DONE.”

Entrepreneur Jan Rabell is one of the most dynamic figures in the Czech Republic’s glassmaking industry. Born in Prague in 1965 to a Puerto Rican father and Czech mother, he grew up in his father’s homeland, later returning to Prague to pursue a master’s degree in economics. He went on to hold various managing director posts in the field of finance and banking. In 1997, he purchased the ailing Janštejn Glassworks and set about restoring its prestige and competitiveness primarily by introducing unconventional glassblowing techniques and production technologies. In 2006, he founded the family-run premium glass lighting brand BROKIS, quickly developing it into one of the most important players in the market and exporting its products around the world. Mr Rabell’s charisma, energy, and innovative vision continue to propel BROKIS and Janštejn Glassworks steadily forward.

LUCIE KOLDOVA

“I SEE A LIGHT AS A SCULPTURE,
AN OBJECT RADIATING ENERGY.
I SHAPE THE ENERGY OF LIGHT
THROUGH THE RELATIONSHIP
BETWEEN THE SOURCE
AND THE GLASS”

BROKIS art director Lucie Koldova is an acclaimed Czech product and furniture designer. Her collaboration with the lighting brand began in 2010 with the timeless Muffins and Balloons collections, which she designed while living and working in Paris. The voluminous glass lights embody her charismatic, elegant style and quickly established BROKIS as an innovative producer of handblown glass lighting. She is the creative force behind the brand and is instrumental in shaping its product portfolio and image. Her creations, objects of desire, include glass sculptures, glass lighting, poetic gallery pieces, and limited series works. Breathtaking colours, unusual proportions, and vibrant formal contrasts move her work seemingly beyond the realm of the possible, a trademark at once apparent in lighting collections such as Macaron, Puro, Ivy, and Spectra. In addition to developing ever-more novel and exciting motifs, Lucie Koldova has introduced important technological and formal solutions that have enabled BROKIS to push the limits of handblown glass production.



PEOPLE



BROKIS has sustainability in its DNA. Natural resources are integral to glassmaking, and BROKIS uses them in accordance with the principles of circular economy. A leader in glass upcycling, BROKIS began developing BROKISGLASS in 2010, achieving 100% reuse of waste glass in a new ecofriendly material. The translucency of BROKISGLASS makes it ideal

for BROKIS lights, and some have won international awards for sustainability. New applications arise from constant innovation. In 2025, BROKISGLASS completed the Life Cycle Assessment (LCA) process and is undergoing EPD certification. See the BROKIS Sustainability Report for details.

In 2023, handmade glass was inscribed in UNESCO's Representative List of the Intangible Cultural Heritage of Humanity. From the very inception of the BROKIS brand, its defining mark has been superior quality in glass artistry and manufacturing. For several centuries, Bohemian glassmaking has been synonymous

with unsurpassed quality and beauty. Today, it is an inseparable part of the cultural legacy of the Czech nation, and we are thrilled that it has been recognized on a global level by UNESCO as a significant manifestation of humanity's living heritage.

SUSTAINABILITY



UNESCO





During the covid pandemic, BROKIS introduced a unique concept of online spaces designed to accentuate the singularity of the brand's lighting collections. Showcasing the lights in realistic interior and exterior settings, these exclusive virtual projects evoke a wide range of emotions. BROKIS conceived the idea at a time when conventional means of presentation were greatly restricted, and the company

was one of the first to pioneer the use of virtual spaces. BROKIS has devoted considerable attention to the various advantages of the virtual platform, one of which is the ease of access to necessary architecture files, technical documentation, and BROKIS innovations. The virtual projects were created by the studios Salaris and Suprema in close collaboration with BROKIS.

In mid-2023, BROKIS organized a photoshoot in Italy and France in collaboration with Italian stylist Simona Sbordone and photographer Max Zambelli. Over 120 lights were photographed in four exclusive locations, using collections from across the BROKIS portfolio. The output of the project is a printed

magazine featuring the majority of the photographs, which was presented to the public in 2024 at Salone del Mobile in Milan and is available to selected business partners and clients. The project was created as a brand statement and marks the beginning of a new chapter of presentation.

VIRTUAL PROJECTS



BROKIS STORYLINE



BROKIS DESIGN BY

LUCIE KOLDOVA

DAN YEFFET

BORIS KLIMEK

CHIARAMONTE MARIN

FUMIE SHIBATA

LENKA DAMOVÁ

VRTIŠKA & ŽÁK

LCM MARIN DESIGN STUDIO

FEDERICO PERI

FILIPPO MAMBRETTI

SIMONA SBORDONE

NOVELTIES

The fleeting moment when molten glass becomes a solid yet infinitely delicate object – such is the inspiration for Under Pressure, a bold new collection of lights that captures this transformation and the exciting tension it creates. That singular, magical instance when hot molten glass succumbs to pressure and begins to assume its final form, an embodiment of strength and fragility in one. The dynamic glass shapes appear still alive, evoking an image of organic deformation from external forces, an invisible pressure bending them to its will. This striking visual effect

is further accentuated with technical elements, such as a centre-line threaded rod that penetrates the delicate glass globe and brings a touch of geometric regularity and industrial elegance. Under Pressure delivers an impressive contrast, an alluring juxtaposition of the organic malleability of glass and uncompromising precision of metal. The lights are manufactured in assorted sizes and typologies, backed with a broad spectrum of glass colour and surface finish options, for a look that always catches the eye and elevates the aesthetics of any interior.

DESIGN

BORIS KLIMEK, LENKA DAMOVÁ



UNDER PRESSURE







UNDER PRESSURE

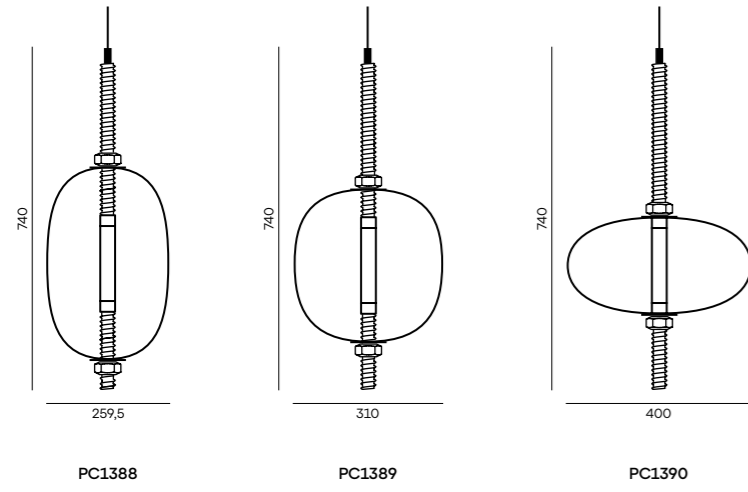

Canopy

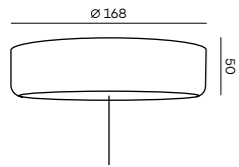

Predefined composition – example

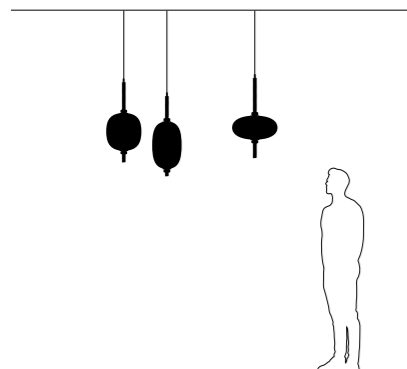
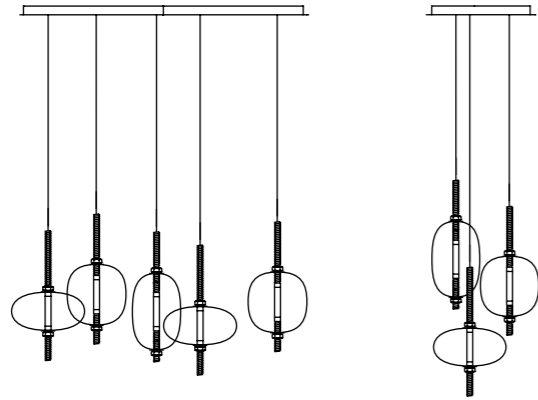

UNDER PRESSURE

GLASS COLOUR

Possible in glossy surface.
Possible Without ornaments or with Crackle.

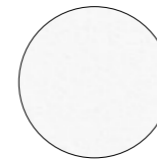

transparent glass

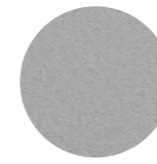

smoke grey - transparent glass



smoke brown - transparent glass

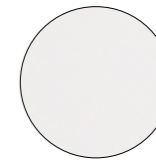

opaline - transparent glass

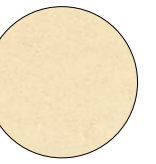

amber - transparent glass

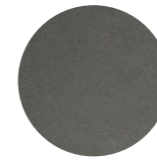

pearl grey - opaline glass



pearl brown - opaline glass



pearl amber - opaline glass

BODY / CANOPY FINISH

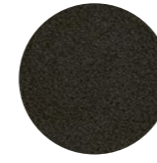

brushed black lacquer



brushed champagne lacquer



brushed bronze lacquer

CABLE COLOUR

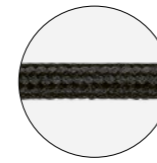

textile cable - black

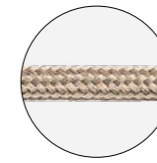

textile cable - light grey

Introducing Comet, an all-new collection of pendant lights combining modern technologies with the timeless beauty of handblown glass. Comet brings a touch of cosmic elegance to the interior in both home and commercial settings. The collection comprises lights inspired by the tail of a comet in the night sky, its effect reminiscent of stardust. The lights are crafted in two shapes – Comet Round and Comet Square – each available in three different sizes. This allows for a wide range of creative compositions, from elegant solitaires to large-scale lighting installations in hotels, staircases, and entrance halls. Each Comet is handblown from laminated glass, with

DESIGN

grains of silica sand added between the layers to render a unique celestial effect that gently diffuses the light throughout the surrounding space. Comet pendants are equipped with modern technologies, such as an efficient LED source and diffuser for both direct and indirect lighting, and fluid touch dimming that puts the desired ambience at the user's fingertips. From minimalist arrangements of a few individual lights to breathtaking curtains of night-sky enchantment, the flexibility of the Comet collection opens exciting new lighting possibilities for commercial and public venues, such as hotels, lobbies, and grand staircases.

SIMONA SBORDONE



COMET





PH14809



PH15746



COMET ROUND

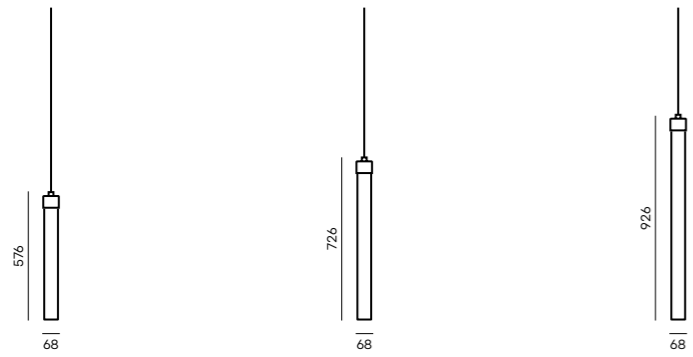

PC1375

PC1376

PC1377

COMET SQUARE

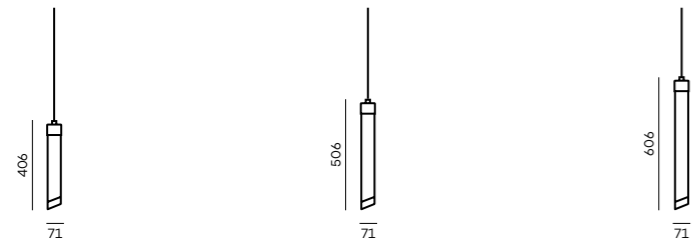

PC1378

PC1379

PC1380

Canopy

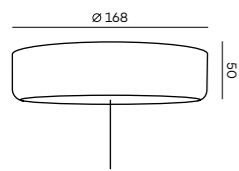

Predefined composition – example

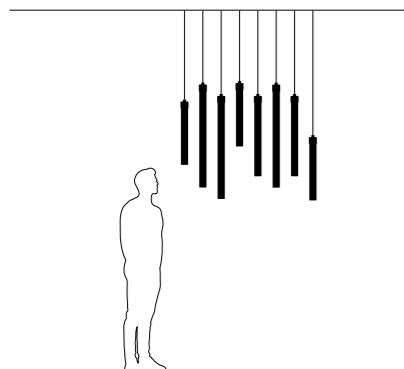
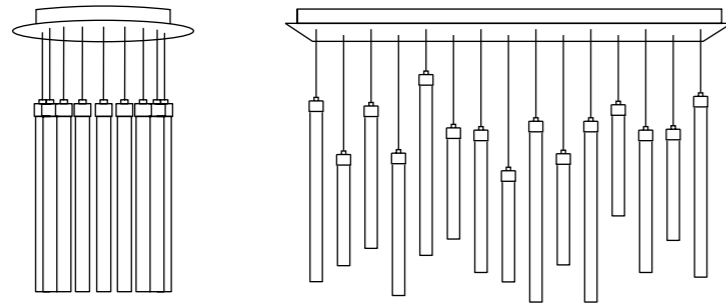

GLASS COLOUR

In glossy surface.
With glass sand decor.

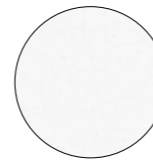

transparent glass

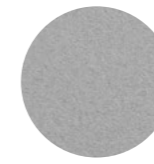

smoke grey –
transparent glass

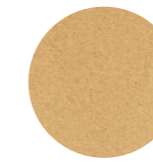

smoke brown –
transparent glass



red – transparent glass

BODY / CANOPY FINISH



brushed champagne
lacquer



brushed bronze lacquer

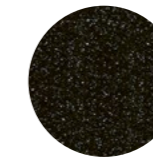

graphite lacquer with
structure

TRIMLESS



trimless – cable version –
white structure

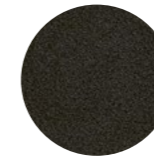

trimless – cable version –
black structure

CABLE COLOUR

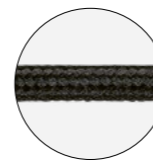

textile cable – black

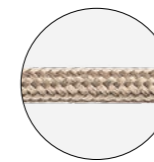

textile cable – light grey



NIGHT BIRDS & MINI



Inspired by the abandon and freedom of bird flight, the innovative Night Birds suspension lights impart poetic enchantment and unparalleled dynamism to any interior. Night Birds differ from the other collections in the unique technology applied in production, which involves melting glass into a mould and then bending it. The process makes it possible to instil delicate nuances in the shape of the wings and achieve a colouration of the glass that is different and wholly unique each time. The restraint and directness of the Night Birds family are underscored by a minimalist LED light source. Night Birds comprises three unique lights, each with a different wing position. They come

in either white, dark (nearly black), or BROKISGLASS, and there is also an outdoor variant. Night Birds are most impressive in large flocks. The indoor and outdoor lights share the same engineering, which allows a greater selection of light sources and simplifies installation and balancing. The Night Birds family has been expanded with a new interior light called Night Birds MINI. This smaller sibling makes the ideal complement to the full-sized lights and is perfect for smaller spaces where larger flocks would appear cramped. Suspended from elegant coaxial cables, MINIs are perfect for illuminating intimate dining areas and conference tables.

DESIGN

BORIS KLIMEK



PH12328



PH12333



PH15645



PH2356

NIGHT BIRDS

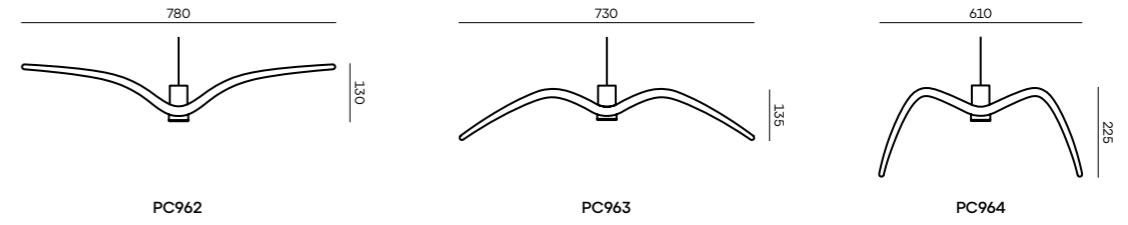

Canopy

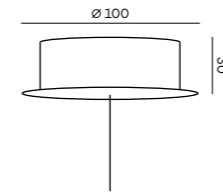

NIGHT BIRDS MINI

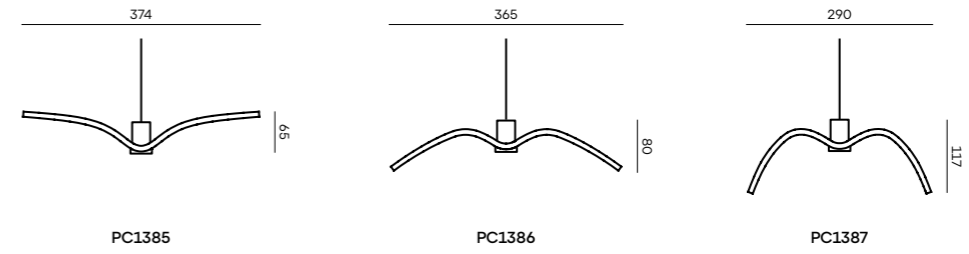

Canopy

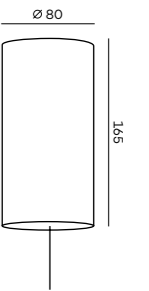

Predefined composition - example

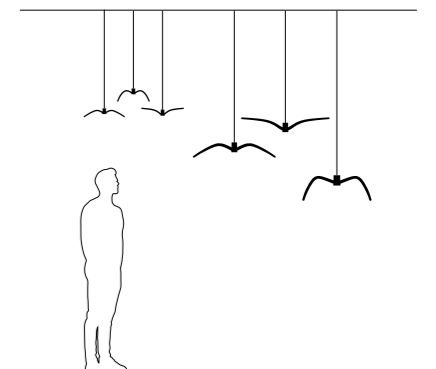
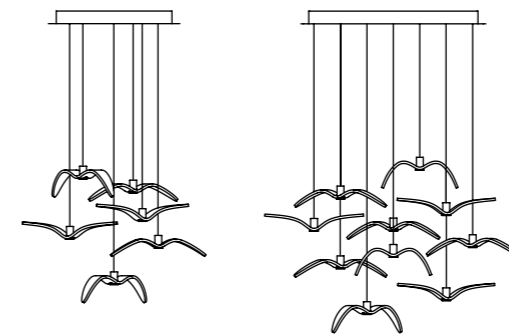

NIGHT BIRDS

NIGHT BIRDS EXTERIOR

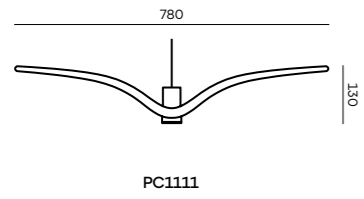

PC1111

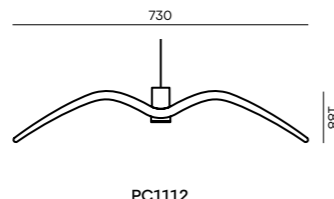

PC1112

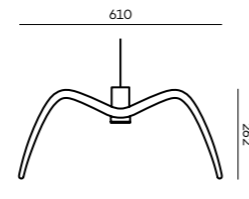

PC1113

Canopy

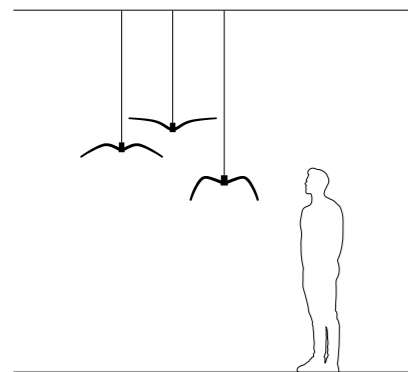
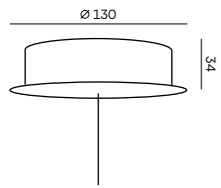

NIGHT BIRDS

GLASS COLOUR

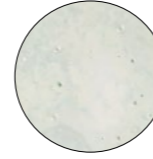

opal - opaque -
massif

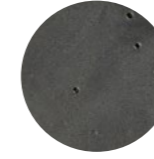

smoke grey - massif



smoke grey
BROKISGLASS matte



triplex opal
BROKISGLASS matte

BODY FINISH

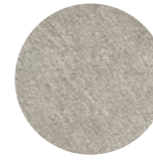

silver anodized

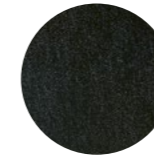

black anodized

CANOPY FINISH

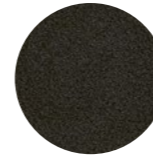

metal - black matte
powder coating

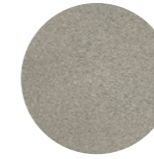

sandblasted aluminium
transparent powder coating

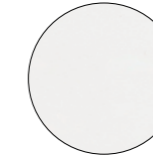

metal - white matte
powder coating

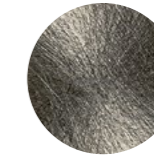

brushed stainless steel

TRIMLESS



trimless - cable version -
white structure

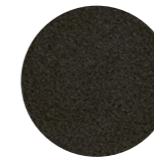

trimless - cable version -
black structure

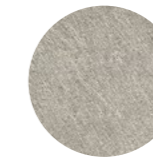

trimless - coaxial cable
version - silver anodized

CABLE COLOUR

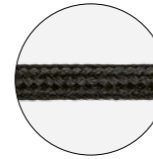

textile cable -
black

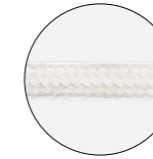

textile cable - white

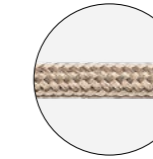

textile cable - light
grey

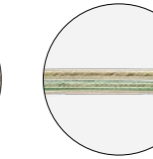

transparent
cable

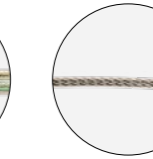

coaxial cable -
silver

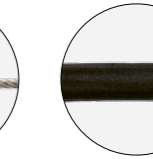

silicone cable -
black

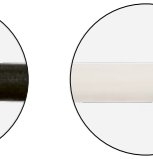

silicone cable -
white

The materials library serves only to provide a general overview of the variants offered within a given collection. For further specification or verification of possible restrictions on individual combinations of colours and/or materials for the product you have selected, please use other sales instruments, such as the Product Sheet, Price List, MyBrokis, etc.

DOME



A nod to classical Roman architecture, Dome is a family of elegant pendant and table lights inspired by the great domes of Venice and evoking the eternity and expansiveness of the celestial vault. The elegant shade, comprising multiple layers of molten glass, each carefully inspected by the master glassmaker prior to blowing, comes in either smooth or wavy clear glass. The gentle illumination is cast forth from a modern LED source concealed beneath an opal diffuser. With the levity of their delicate arches,

the pendants are ideal above large dining tables, either in multi-light compositions or as solitaires, while the table variant brings a unique intimacy to smaller spaces. The Dome family is also home to Dome Nomad, a convenient battery-powered light for outdoor use, whose portability makes it ideal for terraces and gardens. Dome provides a wholly unique lighting experience in both residential and commercial settings.

DESIGN

LCM MARIN DESIGN STUDIO



PH114762

archiproducts
AWARDS
WINNER



PH13819



PH14698



DOME

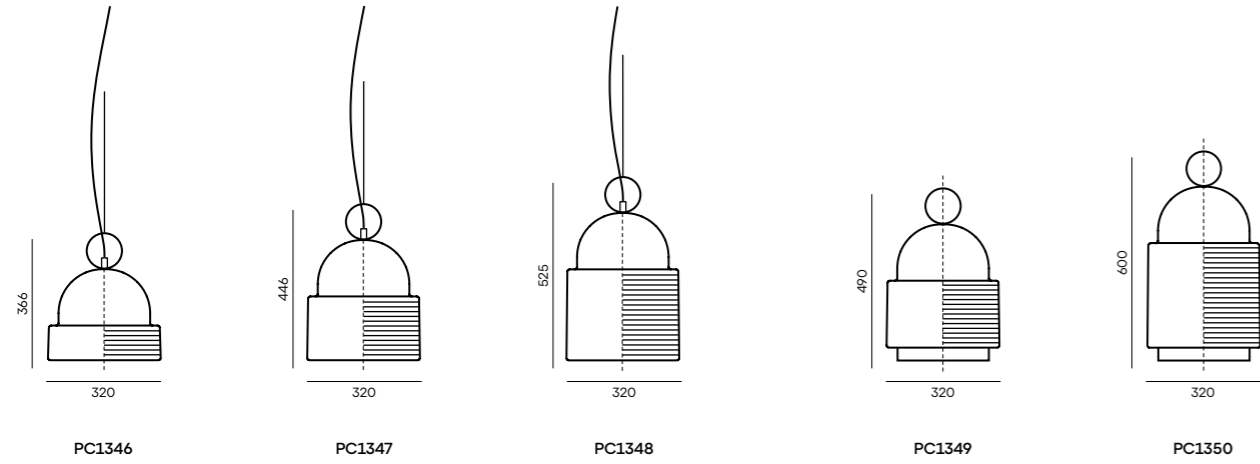

Canopy

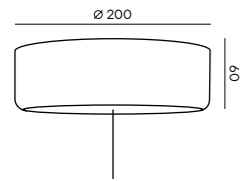

Canopy also for PWM dimming system

DOME NOMAD

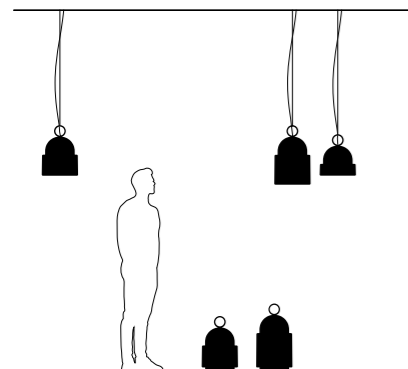
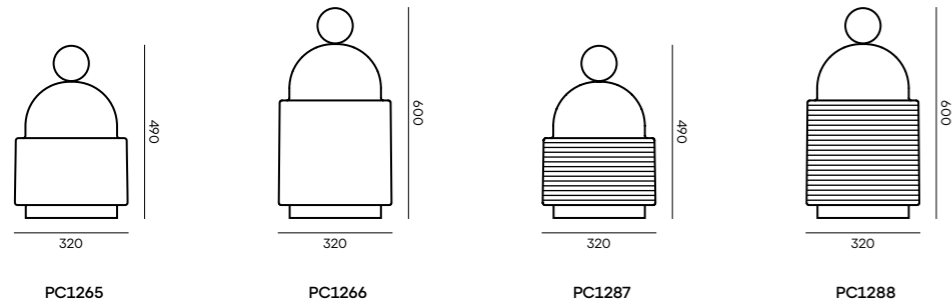

DOME

GLASS COLOUR

In glossy surface.
Possible without ornaments or with lines.

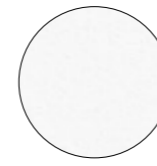

transparent glass

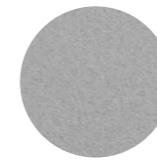

smoke grey – transparent glass

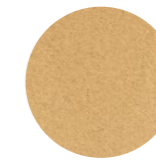

smoke brown – transparent glass

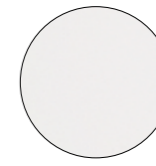

opaline – transparent glass



triplex opal

BODY / CANOPY FINISH



metal – white matte powder coating with structure

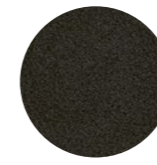

metal – black matte powder coating with structure

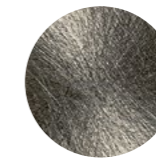

brushed stainless steel



brushed bronze lacquer



brushed champagne lacquer



brushed copper lacquer



brushed rose gold lacquer

CABLE COLOUR

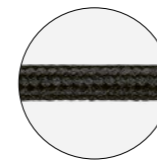

textile cable – black

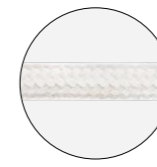

textile cable – white

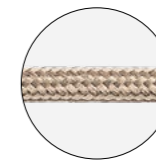

textile cable – light grey

The materials library serves only to provide a general overview of the variants offered within a given collection. For further specification or verification of possible restrictions on individual combinations of colours and/or materials for the product you have selected, please use other sales instruments, such as the Product Sheet, Price List, MyBrokis, etc.

STARCLOUD



Set off on a journey through the heavens with this enchanting masterpiece of stellar beauty, a mesmerizing nebula of gracefully intermingling lights cast against the night sky. This bespoke collection of pendants is based on an abstract astral form, which flows seamlessly into three distinct objects, Atria, Lyra, and Vega, each a work of art in its own right among its celestial companions. These stars project a subtly different optical effect depending on the viewing angle, appearing to variably wax and wane or come to rest in a state of symmetry. Suspended on slender

coaxial cables of varying lengths, the delicate handblown glass shades are available in four variants: opaque opaline, pearl pink opaline, pearl grey opaline, and olive opaline. The collection offers six predefined sets of various sizes, each with its own custom ceiling canopy, but there is no limit to how the lights can be mixed and matched in original compositions. Starcloud thus provides a remarkable degree of variability, inviting users to create their own holly unique interior starscapes. A special online configurator offers even greater possibilities.

DESIGN

LUCIE KOLDOVA







PH14835



PH15643

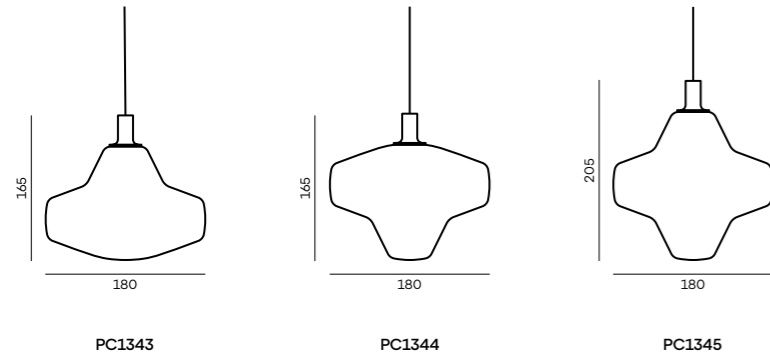

Canopy

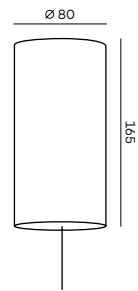

Predefined composition – example

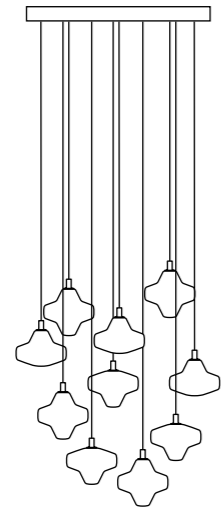

For more predefined or custom compositions visit: configurator.brokis.cz

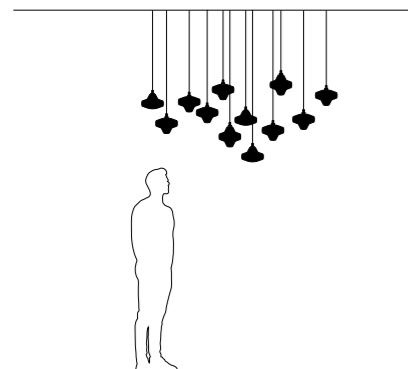

GLASS COLOUR

In glossy surface.
Possible without ornaments or with Bubbles.

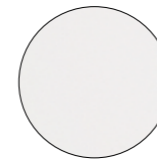

opaline – transparent glass

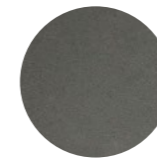

pearl grey – opaline glass



pearl pink – opaline glass



pearl olive – opaline glass

BODY FINISH

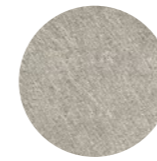

silver anodized

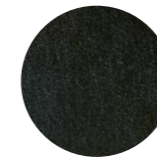

black anodized

CANOPY FINISH



metal – white matte powder coating with structure

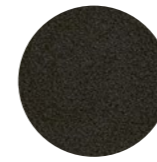

metal – black matte powder coating with structure

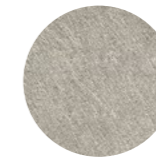

trimless – coaxial cable version – silver anodized



trimless – coaxial cable version – white structure

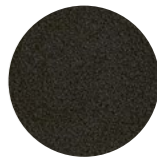

trimless – coaxial cable version – black structure

CABLE COLOUR

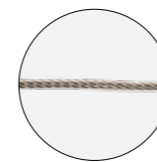

coaxial cable – silver

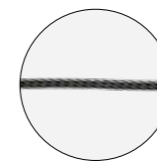

coaxial cable – black

CONVEX



The Convex collection experiments with BROKISGLASS and makes use of its specific properties and processing methods. Designed and manufactured in the form of a convex lens, it pushes the boundaries of function, visual representation, and shaping of this unique and vibrant material. Together with a minimalist, precisely crafted body, it creates an unobtrusive yet unconventional luminaire. The utilitarian design, which highlights the beauty and optical

DESIGN

properties of the glass, is well suited to a broad range of applications in both residential and commercial spaces. The Convex collection comprises a pendant and a wall light, each available in two sizes, whereas the wall variant can also be mounted on the ceiling. Choose from clear triplex opal, or a combination of clear triplex opal and grey triplex opal, where the darker fragments gradually transition to lighter towards the centre of the glass.

BORIS KLIMEK





PH-13820



PH-14673



PH14678



PH14668

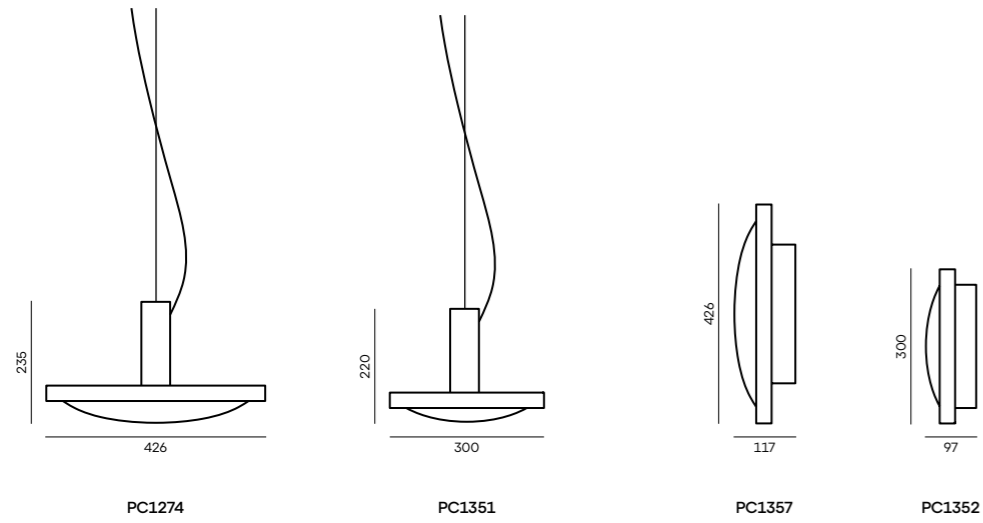

Canopy

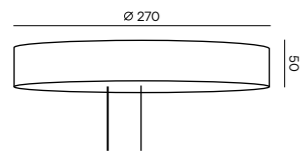

Canopy also for PWM dimming system

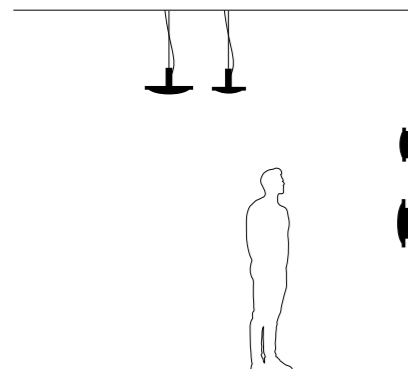

GLASS COLOUR

Possible in glossy finish (front face) and acid-etched finish (front face).



triplex opal BROKISGLASS

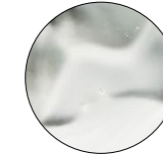

triplex opal + grey triplex opal BROKISGLASS

BODY / CANOPY FINISH

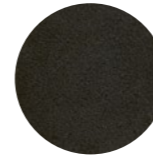

metal – black matte powder coating with structure

CABLE COLOUR

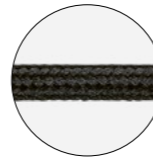

textile cable – black

The outline of the light resembles the classic typology of a table lamp, which has always been a companion to humans during evening sessions. The archetypal silhouette in a purity-of-form concept has an opening with a double-sided light source in an aluminium fixture. The flat source casts its light gently in two directions, upwards and downwards into the glass base, creating intimate atmospheric effects. The two sizes are available in

DESIGN

transparent, smoke brown, smoke grey, or opaline glass. The intensity of the experience can be modulated thanks to an integrated dimmer. The shape of the mantle, which serves as the shade and base in one, evokes a sense of levity and loftiness. A specialized method of glassblowing is needed to create the mantle as a single piece. The overall appearance of the light emphasizes the idea that beauty lies in simplicity.

LUCIE KOLDOVA



SPECTRA





PH14949



PH14844



PH115661



PH114847

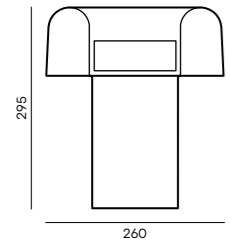

PC1372

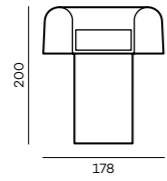

PC1371

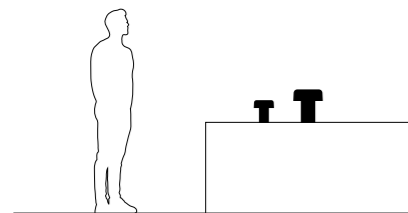

GLASS COLOUR

In glossy surface.

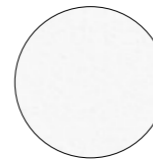

transparent glass

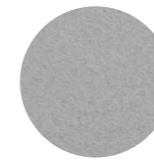

smoke grey – transparent glass



smoke brown – transparent glass

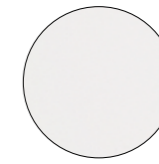

opaline – transparent glass



olive green – transparent glass

BODY FINISH

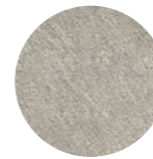

silver anodized

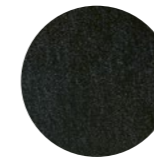

black anodized

CABLE COLOUR

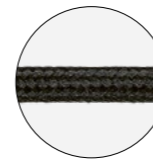

textile cable – black

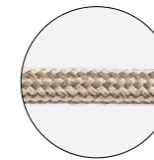

textile cable – light grey

THE BROKIS PORTFOLIO

MUFFINS



The timeless Muffins collection represents an extraordinary lighting experience. Since its market debut, it has taken on an iconic status and become a symbol of the BROKIS brand. The sublimity of the design lies in the masterful combination of delicately contoured glass and solid wood. The lights, featuring a billowing glass shade set in a handcrafted wood base together

with a naked filament bulb, breathe new life into any space and elicit a festive ambience. The collection offers multiple shape and size variants as well as a broad palette of glass colours and woods. To celebrate ten years since the introduction of Muffins, a special anniversary edition was created in 2020 featuring marble and different colours of glass.

DESIGN

LUCIE KOLDOVA, DAN YEFFET





PH956







PH15763

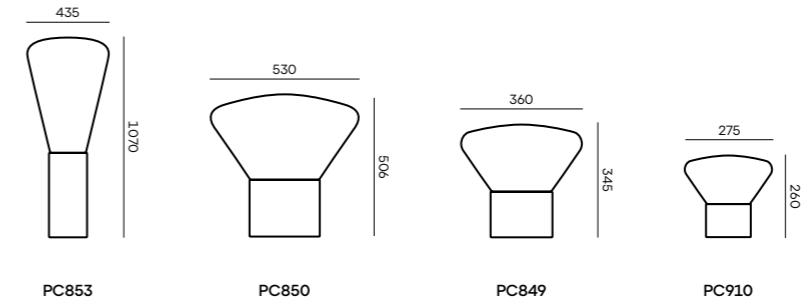
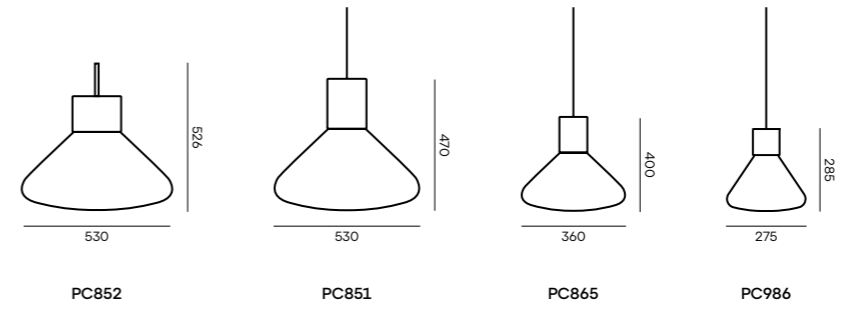

Canopy

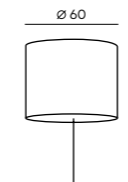

MUFFINS CANDLEHOLDER

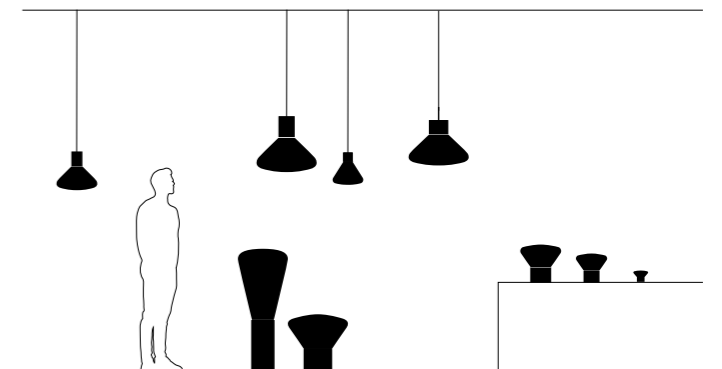
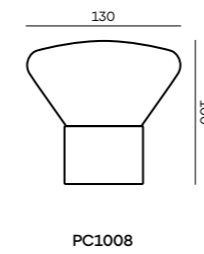

MUFFINS

GLASS COLOUR

Possible in glossy surface.

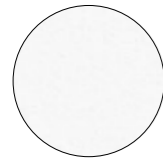

transparent glass



smoke grey - transparent glass



smoke brown - transparent glass

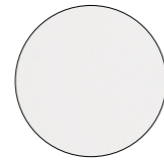

opaline - transparent glass

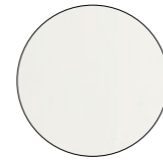

triplex opal



amber - transparent glass

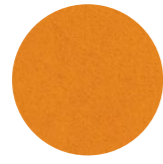

cognac - transparent glass

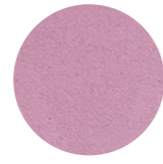

violet - transparent glass



aubergine - transparent glass



olive green - transparent glass



sunset pink - transparent glass

BASE



european oak - untreated



european oak - clear nano coat



european oak - natural lacquer (wax)



european oak - stained black



european oak - stained white



american walnut - natural waxed



satinated grigio talami marble



satinated rosso francia marble

MUFFINS

CANOPY



european oak - untreated



european oak - clear nano coat



european oak - natural lacquer (wax)



european oak - stained black



european oak - stained white



american walnut - natural waxed

CABLE COLOUR

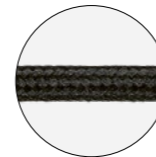

textile cable - black

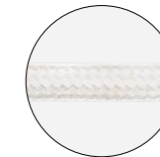

textile cable - white

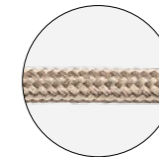

textile cable - light grey

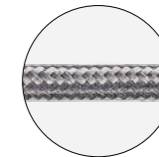

textile cable - dark grey

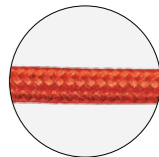

textile cable - red

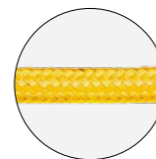

textile cable - yellow

The materials library serves only to provide a general overview of the variants offered within a given collection. For further specification or verification of possible restrictions on individual combinations of colours and/or materials for the product you have selected, please use other sales instruments, such as the Product Sheet, Price List, MyBrokis, etc.

BALLOONS



Balloons, a collection of timeless lights embodying rudimentary forms that evoke images of hot air balloons, captivates with the beauty of large-format handblown glass and an elegant metal reflector hovering within. The design's charm lies in the use of two independent glass sections to achieve the impression of an integral whole. Lavish proportions and an elegant hand-pressed metal reflector are

DESIGN

the collection's defining traits. The size of the largest shade pushes the very boundaries of glassblowing technology and illustrates the exceptional skill and craftsmanship of Bohemian glassmakers. The Balloons collection is one of the pillars of the BROKIS portfolio. The lights come in three sizes. Balloons also make an outstanding sculptural statement during the day when they are switched off.

LUCIE KOLDOVA, DAN YEFFET







PH14293



PH672

BALLOONS

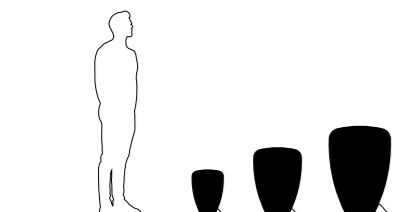
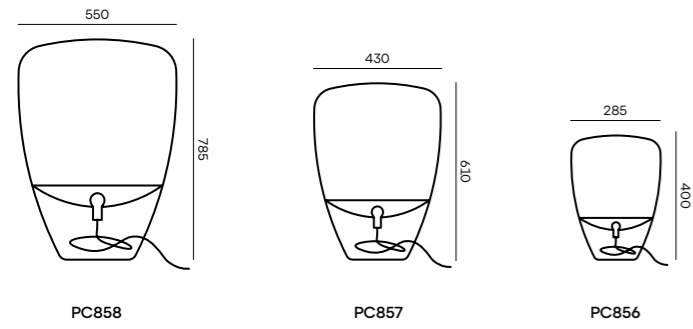

BALLOONS

GLASS COLOUR

In glossy surface.

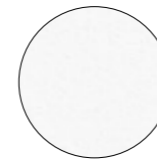

transparent glass

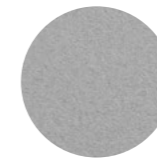

smoke grey –
transparent glass

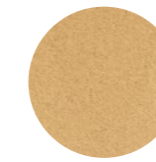

smoke brown –
transparent glass

REFLECTOR

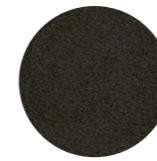

metal – black matte
powder coating

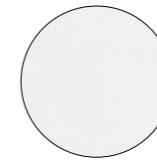

metal – white matte
powder coating

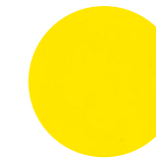

lemon yellow



brass



brushed champagne
lacquer



brushed bronze lacquer

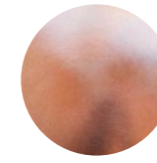

brushed rose gold
lacquer



brushed copper
lacquer

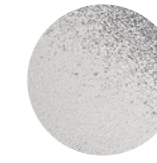

chrome

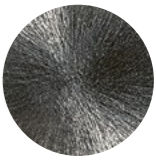

chrome brushed

CABLE COLOUR

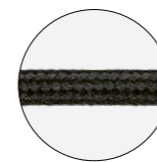

textile cable – black

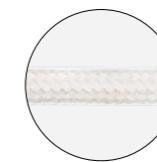

textile cable – white

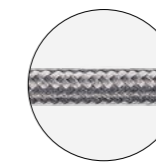

textile cable – dark grey

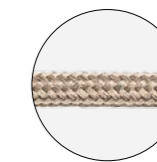

textile cable – light grey

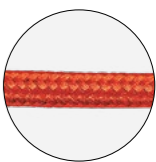

textile cable – red

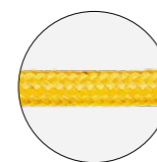

textile cable – yellow

The Shadows family is a take on the famed, timeless lights found in French ateliers, and its typology pays tribute to that legacy. The combination of handblown glass, handcrafted wood, and classic shaping has given rise to a light of ageless elegance. Two collections comprise four different pendants, as striking alone as they are in sets, characterized by a handblown glass shade set upon on a handcrafted wooden fixture. The clean contours and finish are accentuated by the concealed light source. The Shadows family is special not only for its wide spectrum of glass colour options, surface finishes, and types of wood but also because the lights can

DESIGN

be combined in sets according to customer requirements. With near endless combination possibilities, the lights are well suited to a broad range of interior applications. In the Shadows XL collection, the contours remain true to the original Shadows lights but are nearly 50% more robust in their proportions. There is also an outdoor version for installation in exterior settings or interiors with increased humidity levels, such as wellness centres. These feature an IP54 rating and a two-piece weatherproof dural body instead of wood. All Shadows lights are fitted with special integrated connectors developed by BROKIS to facilitate installation and cleaning.

LUCIE KOLDOVA, DAN YEFFET



SHADOWS





SHADOWS

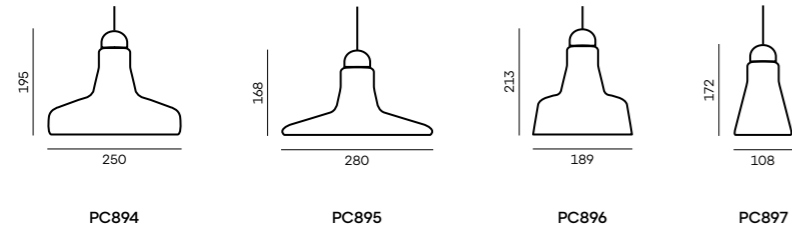

Set and Canopy

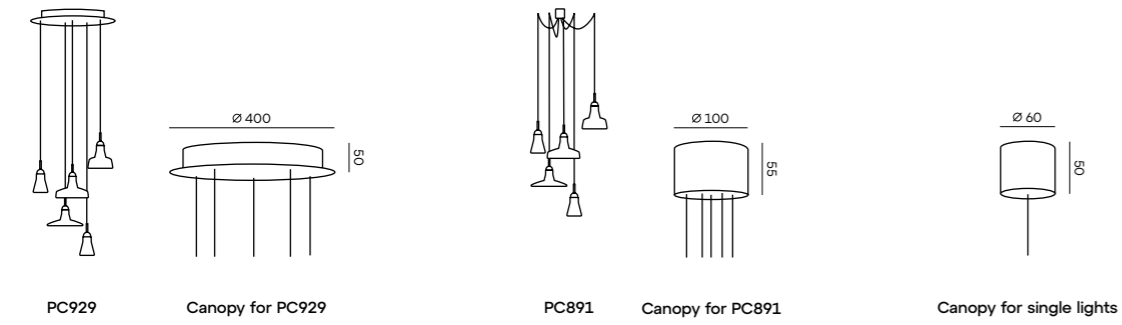
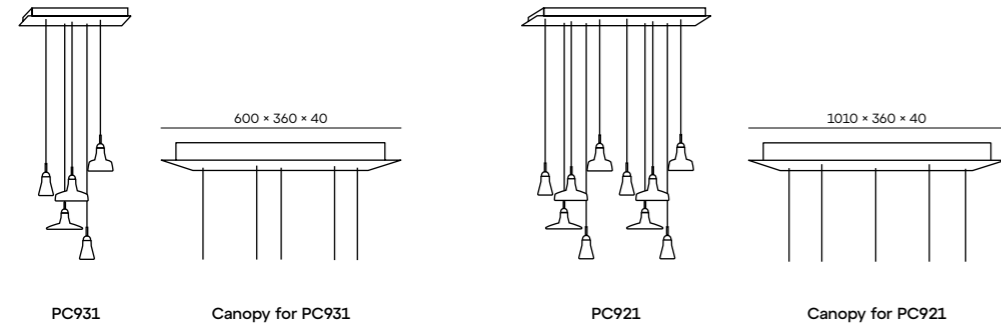

SHADOWS EXTERIOR

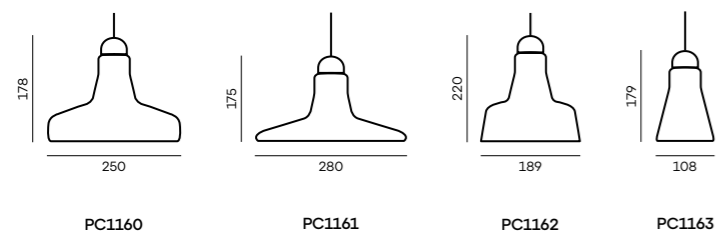

Canopy

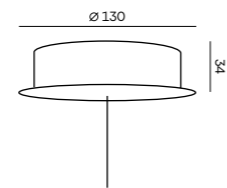

SHADOWS

SHADOWS XL

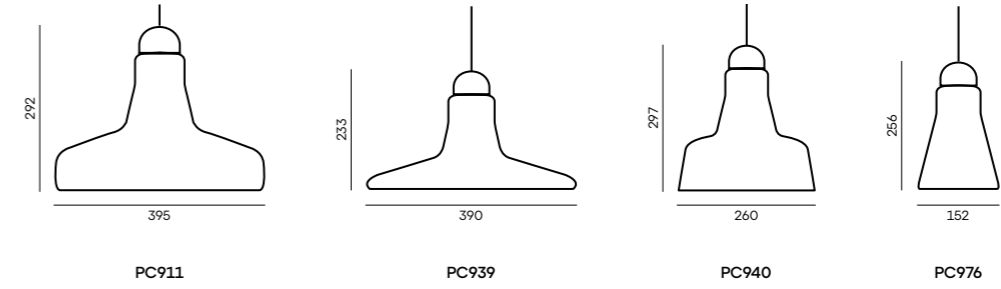

Set and Canopy

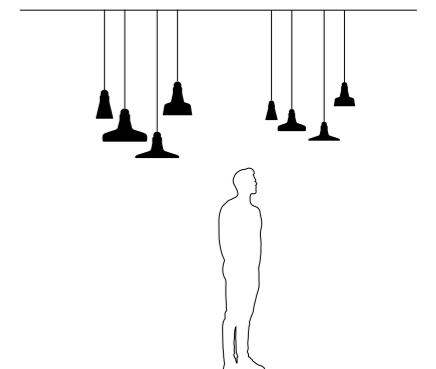
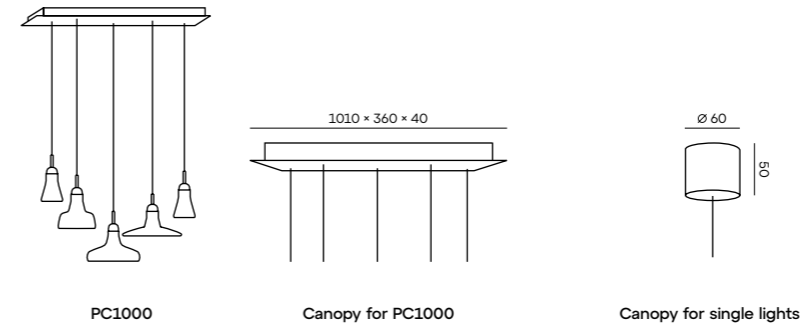

SHADOWS

GLASS COLOUR

Possible in glossy surface and acid-etched outside surface.

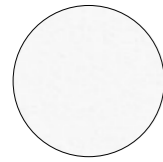

transparent glass



smoke grey - transparent glass



smoke brown - transparent glass

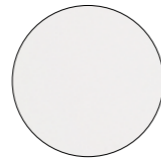

opaline - transparent glass

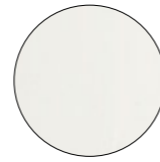

triplex opal



black opaque



pearl grey - opaline glass

LIGHT BODY



european oak - untreated



european oak - clear nano coat



european oak - natural lacquer (wax)



european oak - stained black



european oak - stained white



american walnut - natural waxed

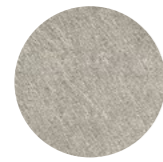

silver anodized



black anodized

SHADOWS

CANOPY



european oak - untreated



european oak - clear nano coat



european oak - natural lacquer (wax)



european oak - stained black



european oak - stained white

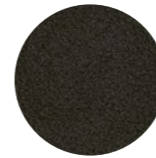

metal - black matte powder coating

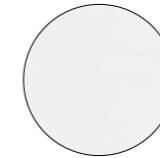

metal - white matte powder coating



american walnut - natural waxed

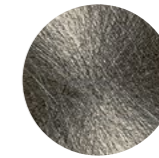

brushed stainless steel

TRIMLESS

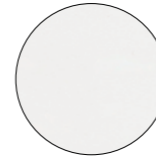

trimless - cable version - white structure

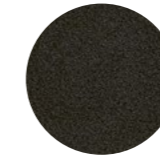

trimless - cable version - black structure

CABLE COLOUR

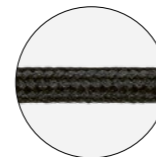

textile cable - black



textile cable - white

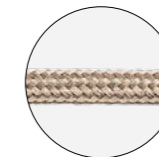

textile cable - light grey

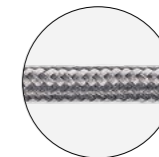

textile cable - dark grey

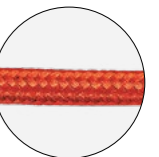

textile cable - red

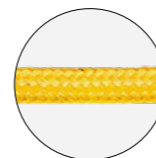

textile cable - yellow



silicone cable - black

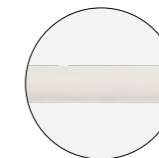

silicone cable - white

The materials library serves only to provide a general overview of the variants offered within a given collection. For further specification or verification of possible restrictions on individual combinations of colours and/or materials for the product you have selected, please use other sales instruments, such as the Product Sheet, Price List, MyBrokis, etc.

MEMORY



The Memory collection awakens the imagination and beckons back to a carefree childhood. The wall and ceiling versions in different sizes, the wide range of colour options, and a selection of finishes give this lighting experience a large degree of versatility. The illusion of inflated balloons is flawless right down to the dangling string, which serves to switch

DESIGN

the light on and off. This is beauty in its simplest and most persuasive form. The Memory collection consists of ceiling and wall versions in three sizes. There are also sets that allow multiple lights to be combined on a single ceiling canopy. New colours and shapes are now available in celebration of the collection's ten-year anniversary.

BORIS KLIMEK

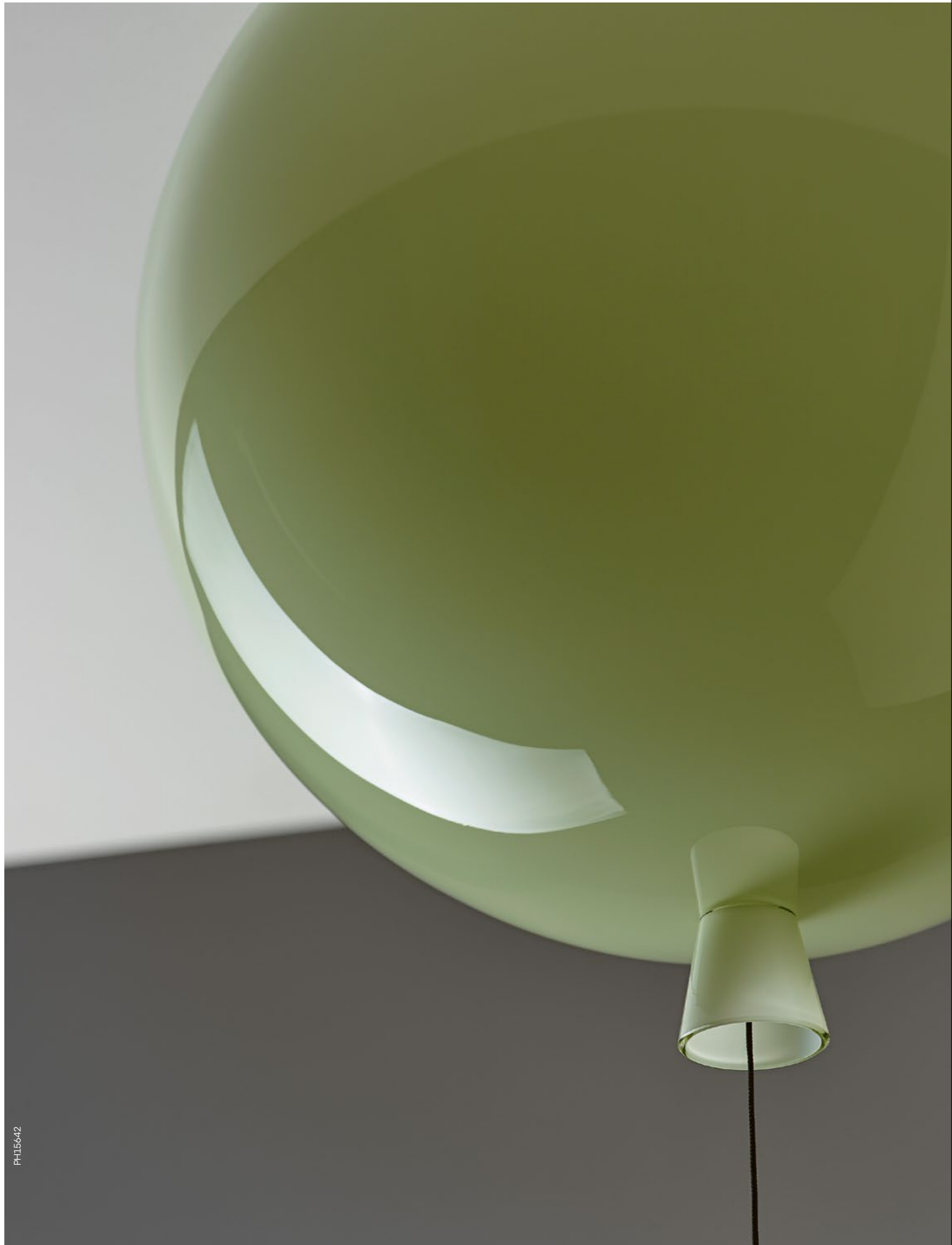

PH115642



PH112479

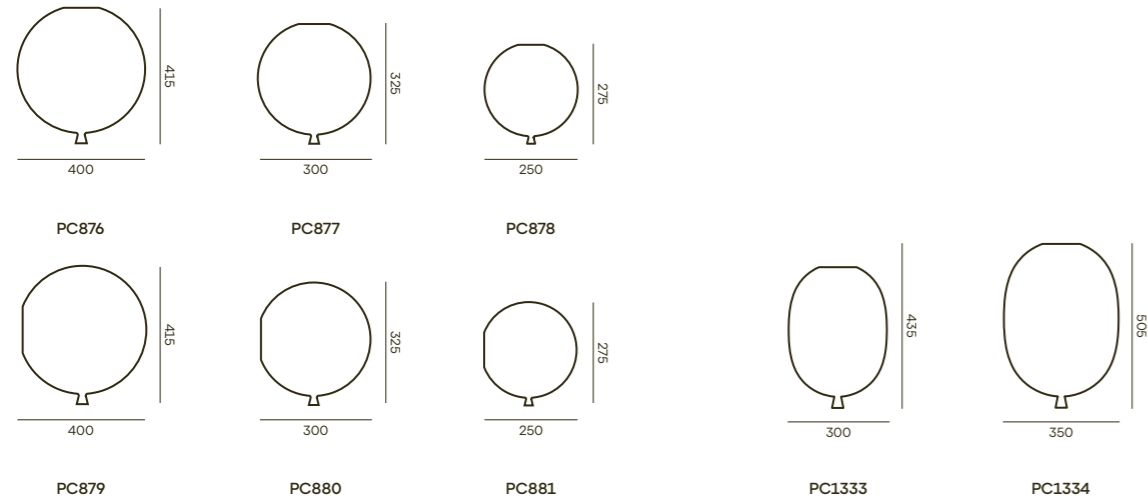

Set and Canopy

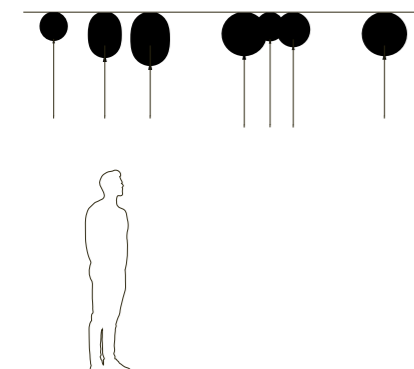
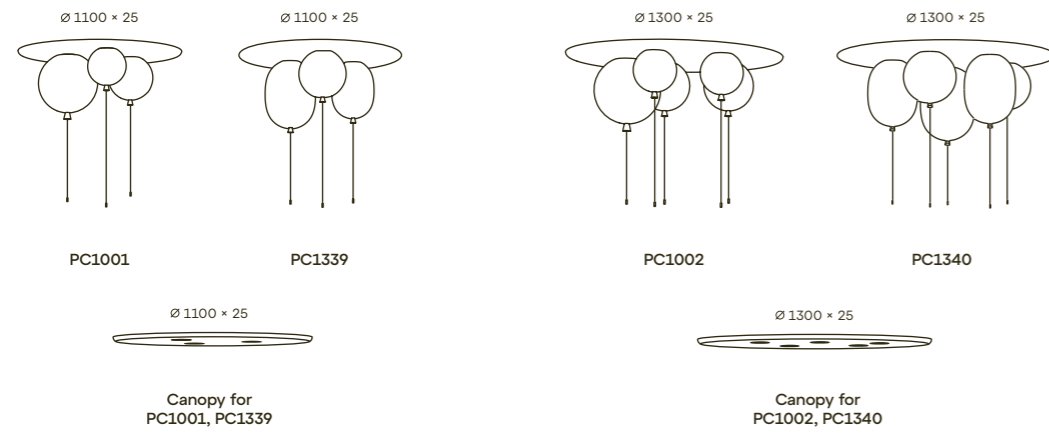

GLASS COLOUR

Possible in glossy surface and acid-etched both side surface.



BODY FINISH



CANOPY FINISH



ENDING PART AND CORD

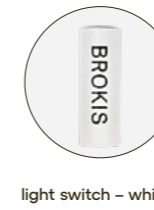
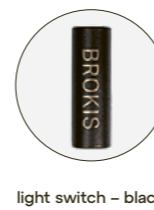

Capsula is a sophisticated and exhilarating light bearing resemblance to a plant cell or seed. The nucleus of the piece is a tubular triplex-glass LED light source, developed by BROKIS, that transects the inner shade and translucent external shell to form a notional axis. The layering and overlapping of these three distinct components give rise to dramatic 3D optical effects. The end caps fasten the components together and serve as anchor points for the creative dual suspension straps, which also conceal the power cable and

allow for variation in the final positioning of the light. The Capsula collection is offered in sets as well as individual lights that can be combined per customer requirements. As of spring 2018, Capsula is fitted with special integrated connectors developed by BROKIS to facilitate installation and cleaning. Beginning in 2025, the collection features a new BROKISGLASS option, bringing a refreshed visual experience that further underlines the overall singularity of the lights.

DESIGN

LUCIE KOLDOVA



CAPSULA







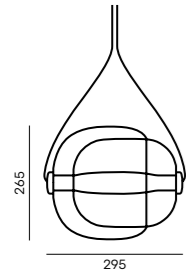

PC937

Set and Canopy

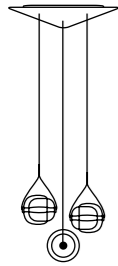

PC943

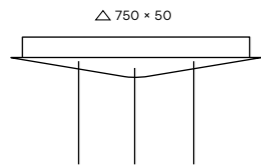

Canopy for PC943
incl. PWM dimming system

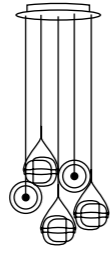

PC966

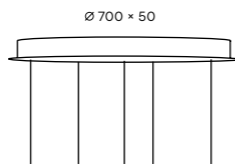

Canopy for PC966
incl. PWM dimming system

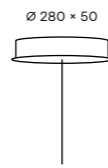

Canopy for single lights
incl. PWM dimming system

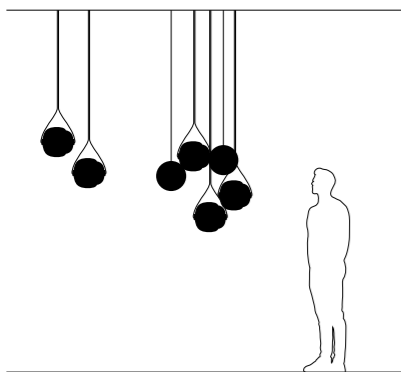

COLOUR OF THE OUTSIDE GLASS AND INSIDE GLASS

Possible in glossy surface and acid-etched both side surface.

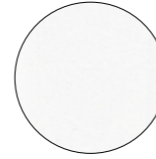

transparent glass

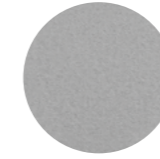

smoke grey - transparent glass

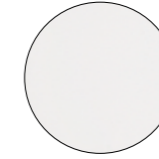

opaline - transparent glass



amber - transparent glass

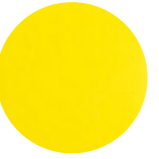

yellow - transparent glass



violet - transparent glass



red - transparent glass

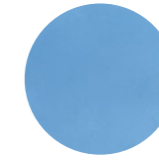

light blue - transparent glass

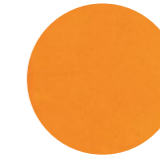

orange - transparent glass



olive green - transparent glass

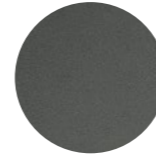

pearl grey - opaline glass



BG decor brown mat

BODY FINISH

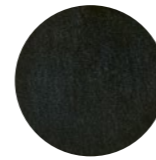

black anodized

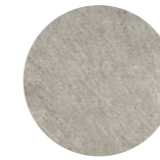

silver anodized

CANOPY



metal - black matte powder coating



metal - white matte powder coating

CABLE COLOUR

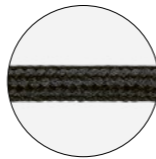

textile cable - black

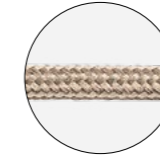

textile cable - light grey

MONA

The Mona family is based on the concept of penetrating forms. The light source boldly traverses the ample volume of smooth handblown glass to reveal the thrilling tension inherent in the design. The collection's essence, however, lies in its unconventional construction and refined combination of materials. It also boasts dimmable tubular LED light sources, developed by BROKIS, each with a different colour temperature. The entire Mona family has been technologically improved with innovative connectors

and the replacement of the wood components with metal ones. These improvements make it easier to change out the light source and clean the lights. The wall variant is dimmable via a newly integrated dimmer in the lower part of the metal fixture, and the table variant now offers touch dimming. Mona offers a wide selection of glass and leather strap colour options. The collection comprises several sizes (S, M, L, XL) and various types of lights (pendant, floor, table, wall).

DESIGN

LUCIE KOLDOVA





PH926



PH9471



PH10898



PH1005

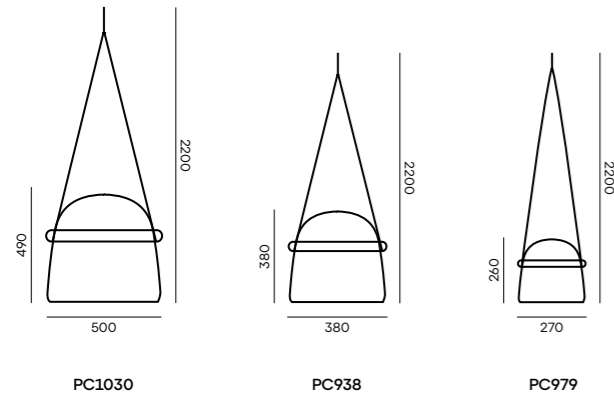
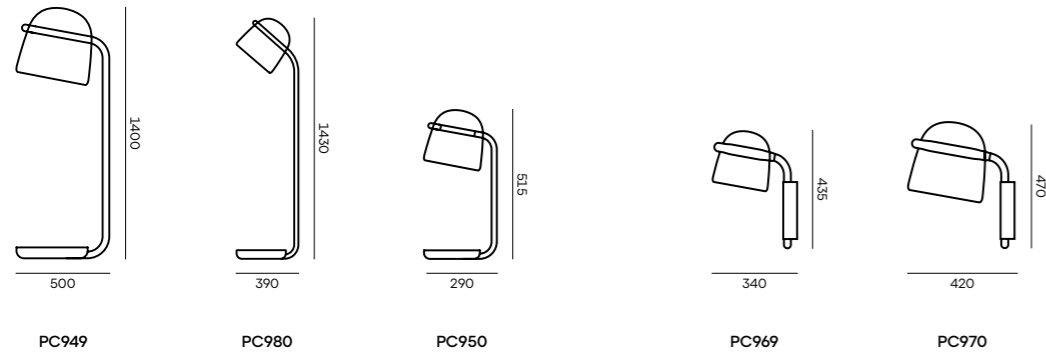

Canopy

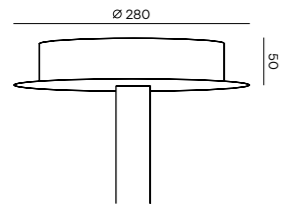

Canopy also for PWM dimming system

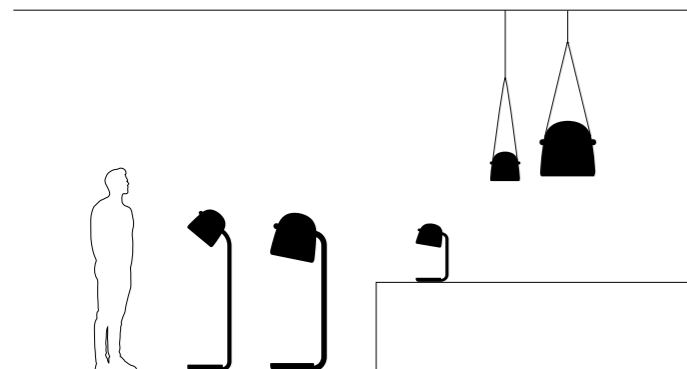

GLASS COLOUR

In glossy surface.



BODY FINISH



STRAPS



CANOPY

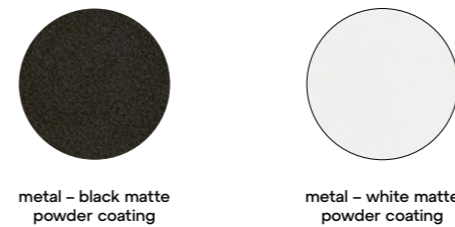

CABLE COLOUR

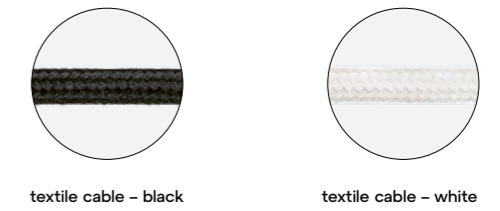

The materials library serves only to provide a general overview of the variants offered within a given collection. For further specification or verification of possible restrictions on individual combinations of colours and/or materials for the product you have selected, please use other sales instruments, such as the Product Sheet, Price List, MyBrokis, etc.

WHISTLE

PH-6358



The Whistle collection is, quite literally, a living reference to the work of glassmakers, as inspiration for the design was taken from the blowpipe, which in Czech is known as a glassmaker's whistle. The lucid body of the piece traces the silhouette of a cone of light, and a distinct spotlight with hand-pressed metal shield constitutes its imaginary heart. The overall shape and the naked cable winding its way up

through the body of the light define the character of its simplistic technical form. The collection comprises a suspension light in two sizes as well as a set of three lights, each available with a broad choice of glass colours and surface finishes. As of March 2018, Whistle is fitted with special integrated connectors developed by BROKIS to facilitate installation and cleaning.

DESIGN

LUCIE KOLDOVA





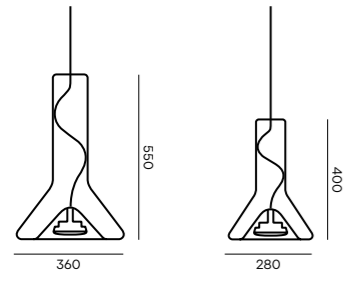

PC953

PC952

Set and Canopy

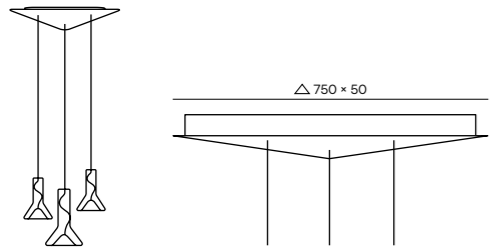

PC961

Canopy for PC961

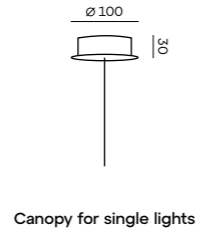

Canopy for single lights

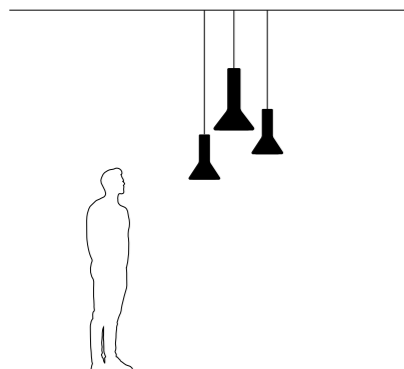

GLASS COLOUR

In glossy surface.

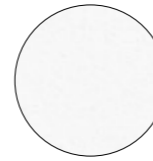

transparent glass

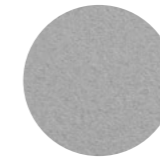

smoke grey – transparent glass



smoke brown – transparent glass

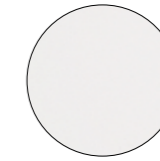

opaline – transparent glass

REFLECTOR / CANOPY

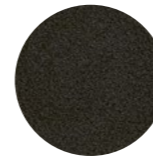

metal – black matte powder coating

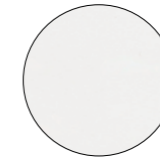

metal – white matte powder coating

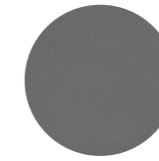

grey

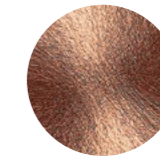

copper



brass

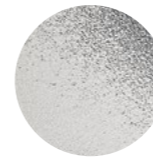

chrome

TRIMLESS

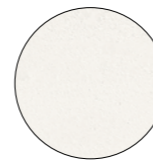

trimless – cable version – white structure



trimless – cable version – black structure

LIGHTLINE



In its every component, the Lightline collection is a celebration of glass as an artistic medium. The concept of a line of light is rooted in the varying characteristics of the material and its forms. The design employs the effect of light uniformly dispersed over a sandblasted surface, which in profile creates the impression of a luminous line.

DESIGN

The LED light source is embedded in the base beneath a metal and triplex opal glass shroud. The upper surface, sandblasted by hand, is treated with a special nano coating to prevent the accumulation of dust and smudges. The collection comprises four table lamps that cast a light of intimate character.

LUCIE KOLDOVA





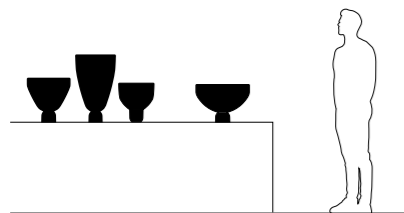
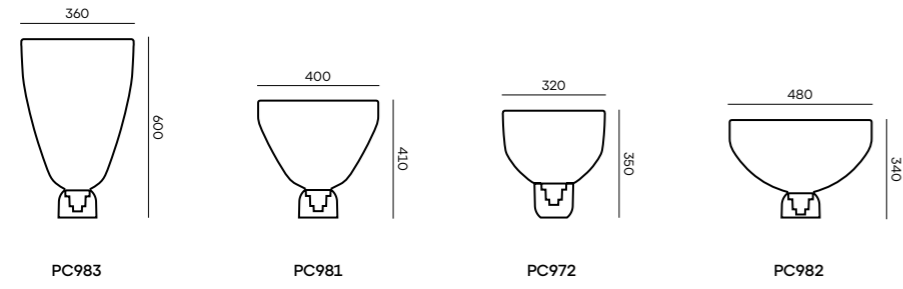

COLOUR OF THE UPPER PART GLASS

In glossy - sandblasted (top part).

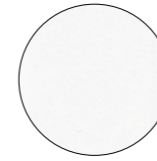

transparent glass

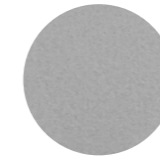

smoke grey - transparent glass

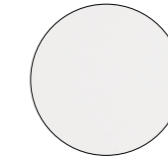

opaline - transparent glass



amber - transparent glass



violet - transparent glass



red - transparent glass

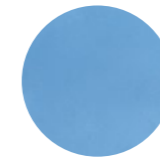

light blue - transparent glass

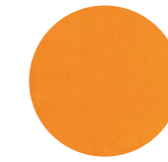

orange - transparent glass



menthol - transparent glass

COLOUR OF THE BOTTOM PART GLASS

Possible in glossy surface and acid-etched both side surface.

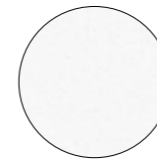

transparent glass

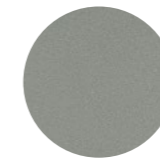

dark smoke grey - transparent glass

CABLE COLOUR

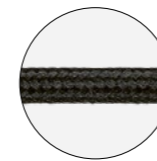

textile cable - black

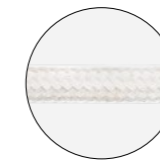

textile cable - white

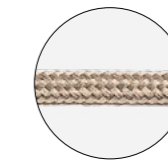

textile cable - light grey

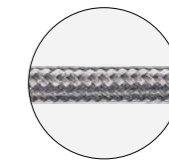

textile cable - dark grey

Knot, a family of stately pendent lights, contrasts two dissimilar materials, two dissimilar notions: gentle curves in clear handblown glass against the austerity of coarse rope. The resulting design is striking and forthright yet dignified at the same time. Full-bodied globes of varying shapes and sizes are penetrated by robust rope ending in the core design element of the collection – the knot – which seemingly pulls the bottom of the glass inward for a bemusing plastic effect. The LED light source is mounted

beneath an elegant hood made of stamped metal and protected from below by a handblown triplex opal diffusor. Another metal component serves to cap the end of the rope. The family comprises lights of four different shapes in two sizes with a variety of colour options. Additionally, there is a romantic table light, now available in a variant for exterior use, and a portable battery-powered light, both of which are manufactured in two different sizes.

DESIGN

CHIARAMONTE MARIN



KNOT



PH14405



PH1625





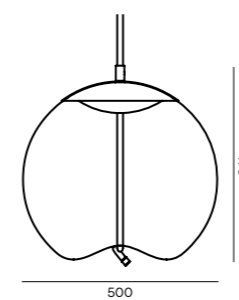

PC1016
Sfera

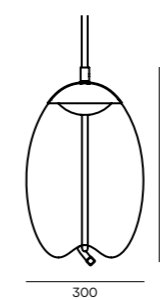

PC1018
Uovo

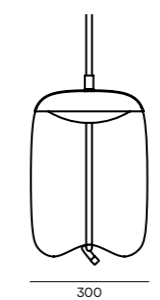

PC1019
Cilindro

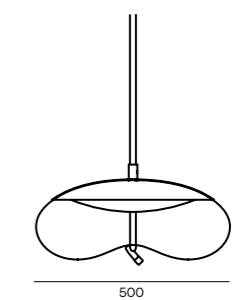

PC1017
Disco

Canopy

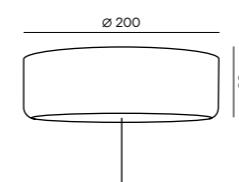

Canopy also for
PWM dimming system

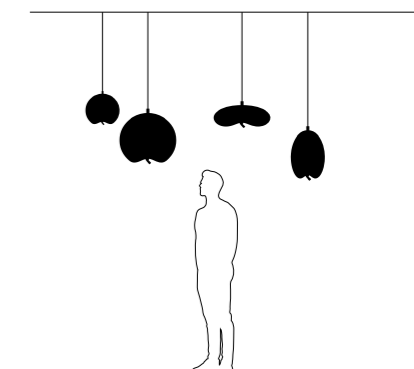

KNOT SMALL

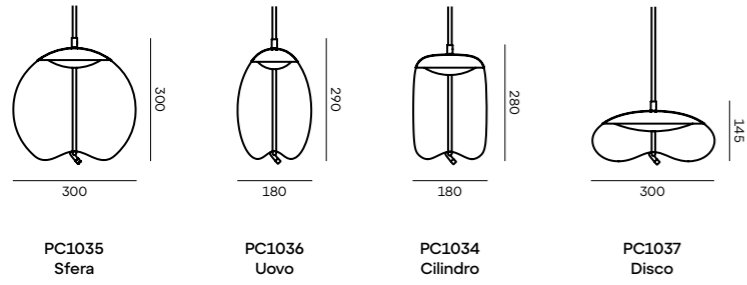

Canopy

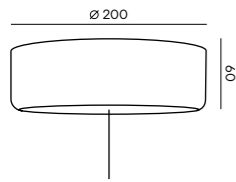

Canopy also for PWM dimming system

KNOT TABLE

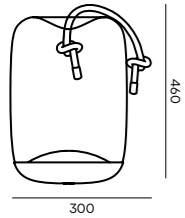

PC1078
Cilindro table

KNOT BATTERY

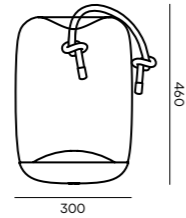

PC1249
Cilindro

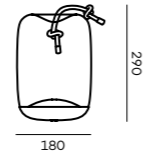

PC1250
Small Cilindro

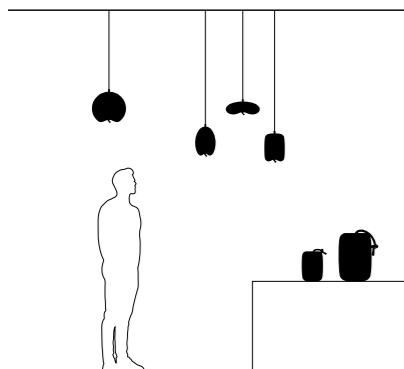

GLASS COLOUR

Possible in glossy surface and matte inner glass finish.

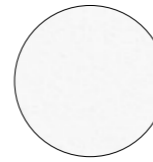

transparent glass

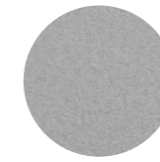

smoke grey –
transparent glass

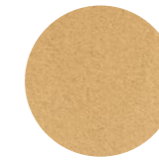

smoke brown –
transparent glass

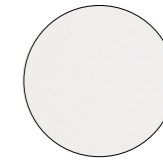

opaline –
transparent glass

REFLECTOR / BODY / CANOPY

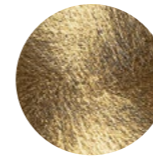

bras

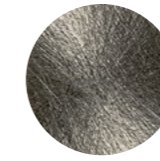

brushed stainless steel

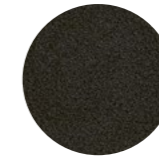

metal – black matte
powder coating with
structure



metal – white matte
powder coating with
structure



brushed bronze
lacquer



brushed champagne
lacquer



brushed copper
lacquer



brushed rose gold
lacquer

TRIMLESS



leather straps – black

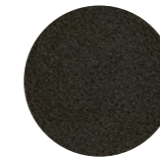

leather straps – natural

CABLE COLOUR

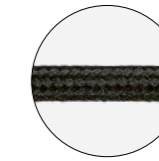

textile cable – black

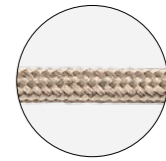

textile cable – light grey

ROPE



rope – natural

The materials library serves only to provide a general overview of the variants offered within a given collection. For further specification or verification of possible restrictions on individual combinations of colours and/or materials for the product you have selected, please use other sales instruments, such as the Product Sheet, Price List, MyBrokis, etc.

PURO



Puro is a boldly minimalistic variation on atmospheric pendent lights. Inspiration for the collection and its name come from the Spanish word for “cigar”, which also means “pure” and is a reference to the composition’s clean lines. The original design in the Puro family creates an intriguing interplay between horizontal and vertical luminous cigar tubes levitating in space above simple bell lights. The diffused glow of the tubes combines with that of the bells to elicit a dynamic ambience, while the alternating gloss and matte finishes provide a degree of provocation. The first variations to appear were a bell light suspended beneath a single vertical tube and dual bell lights suspended beneath a single horizontal tube.

DESIGN

LUCIE KOLDOVA

Multiple tubes can be combined to create amazing installations, such as a screen to divide space and evoke an intimate atmosphere bordering on scenography. BROKIS has an online configurator to simplify the creation of unique lighting compositions. The endless variability of the Puro collection gives rise to new lighting objects for any interior. The Puro family – Solo, Single, Spotlight, Eclectic, Contour, Sparkle, and Floor – are available in various sizes in either matte triplex opal or smoke grey glass. Puro have special integrated connectors developed by BROKIS for improved variability and ease of installation and cleaning.

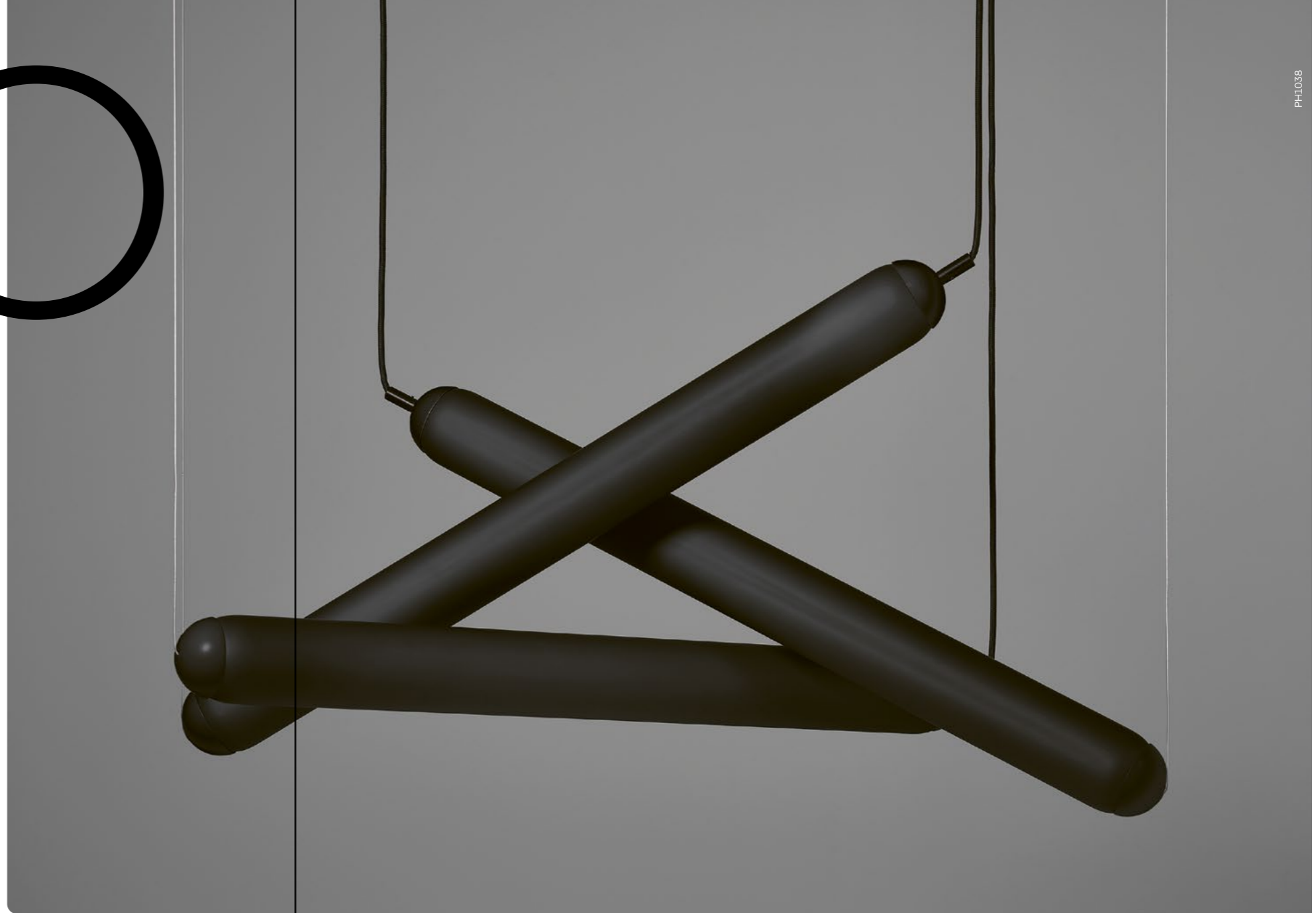



PH1051



PH15748



PH6517



PH6998

PURO SOLO

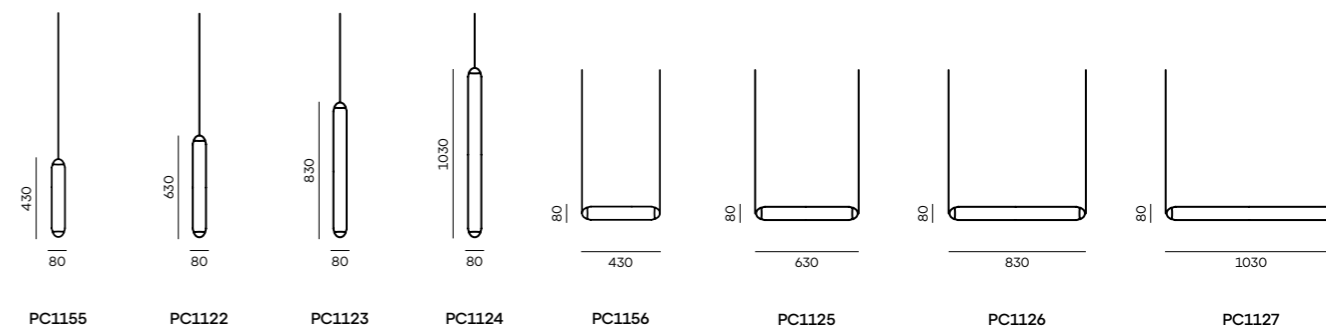

PURO SINGLE

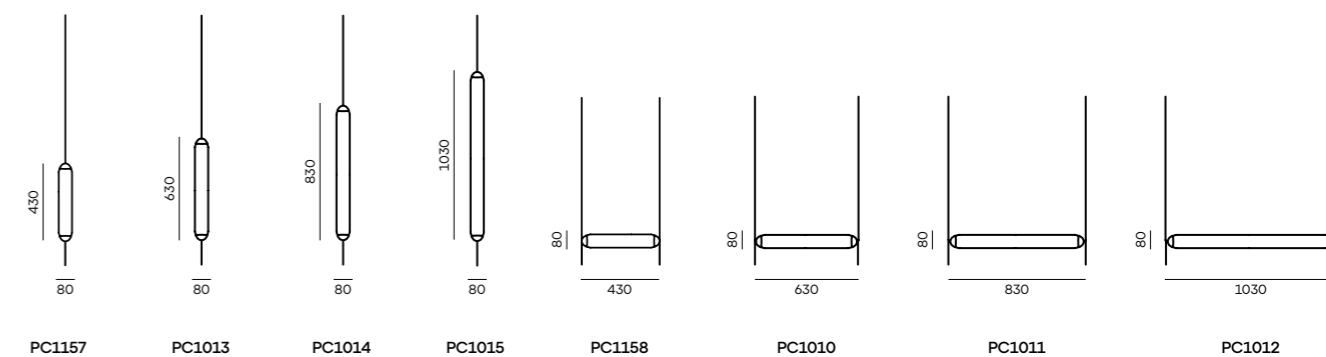

Canopy

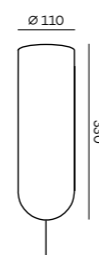

Canopy also for PWM dimming system

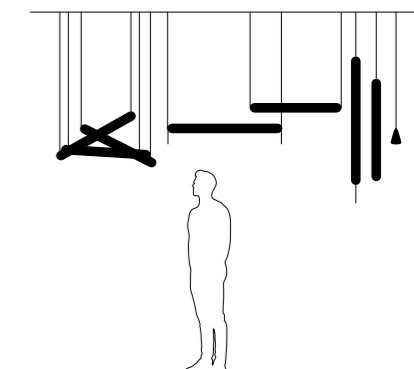

For custom configurator of composition visit: configurator.brokis.cz

PURO SPOTLIGHT



120

PC1121

Canopy

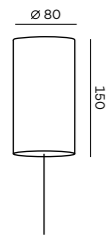

Non-dimmable version

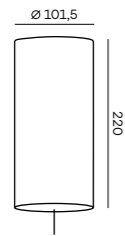

Dimmable version also for PWM dimming system

PURO ECLECTIC

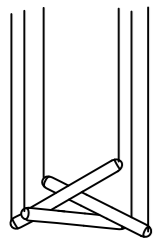

PC1114

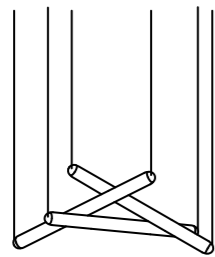

PC1115

Canopy

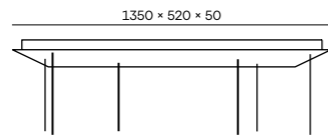
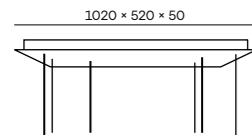

PURO CONTOUR

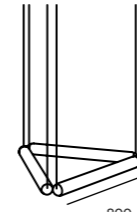

PC1118

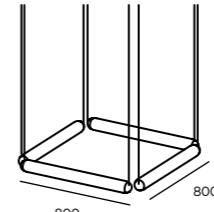

PC1073

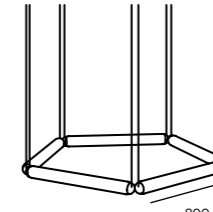

PC1119

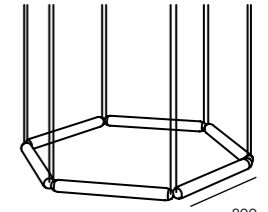

PC1120

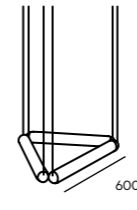

PC1133

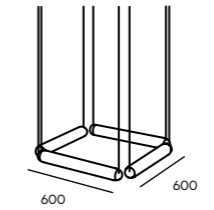

PC1057

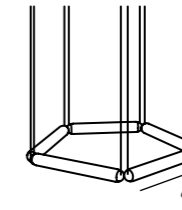

PC1135

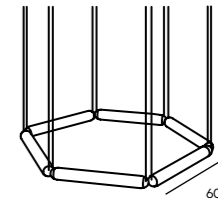

PC1137

Canopy

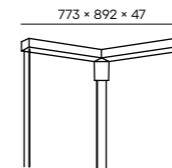

Canopy for PC1118
incl. PWM dimming system

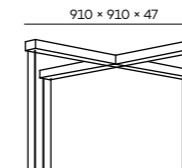

Canopy for PC1073
incl. PWM dimming system

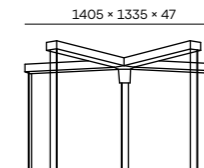

Canopy for PC1119
incl. PWM dimming system

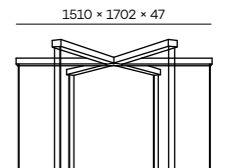

Canopy for PC1120
incl. PWM dimming system

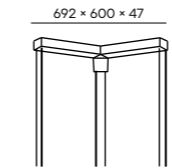

Canopy for PC1133
incl. PWM dimming system

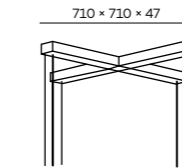

Canopy for PC1057
incl. PWM dimming system

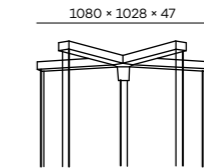

Canopy for PC1135
incl. PWM dimming system

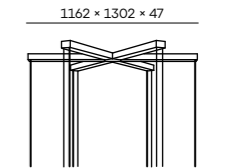

Canopy for PC1137
incl. PWM dimming system

PURO SPARKLE

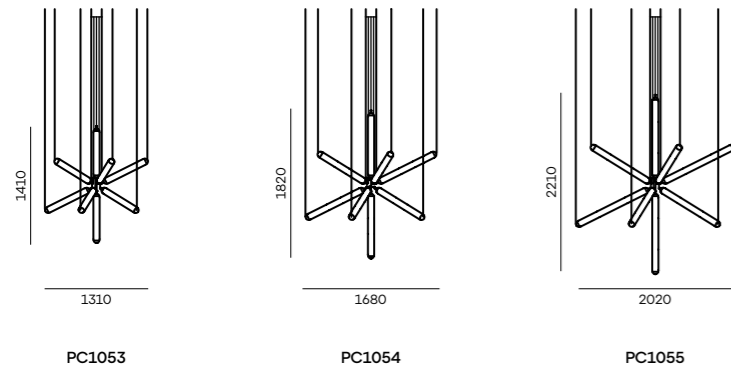

Canopy

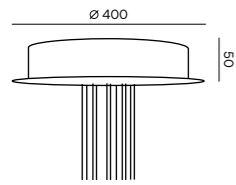

Canopy also for PWM dimming system

PURO FLOOR

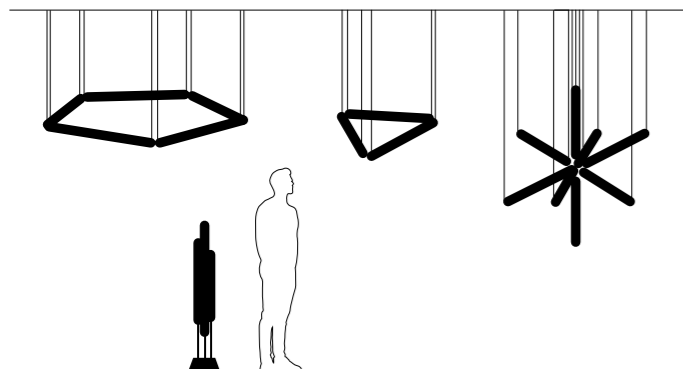
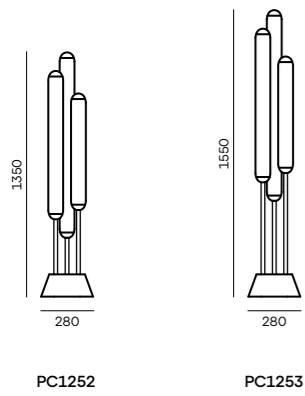

GLASS COLOUR

In acid-etched both side surface.

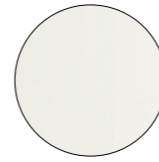

triplex opal



dark grey - opaline

BOTTOM GLASS COLOUR

Possible in glossy surface and acid-etched both side surface

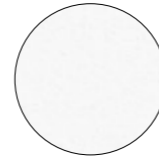

transparent glass

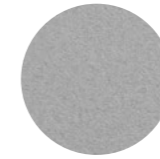

smoke grey - transparent glass

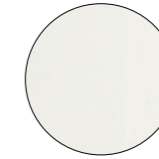

triplex opal

BODY FINISH

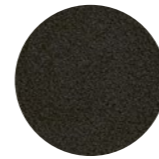

metal - black matte powder coating

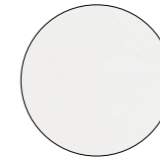

metal - white matte powder coating

CANOPY

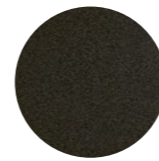

glass - black

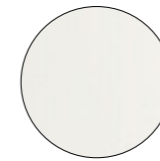

glass - white

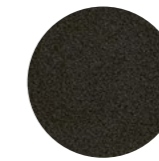

metal - black matte powder coating



metal - white matte powder coating

TRIMLESS



trimless - cable version - white structure

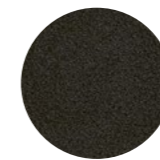

trimless - cable version - black structure

CABLE COLOUR

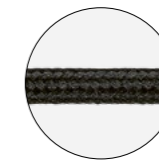

textile cable - black

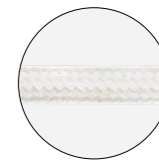

textile cable - white

MACARON



The Macaron table light pays homage to the beauty and complex structures of crystalline stone. Enclosed in opposing domes of delicate handblown glass, the stone becomes a moonscape afloat in its own cosmos. The light source casts its glow upward from the onyx base to energize the meandering chalcedony veins in the centre onyx plate and create a subtle and mesmerizing lighting effect. The concept is based on the principle of illuminating stone, and the name refers to the light's similarity in shape to the famed French meringue confection. Natural imperfections in the glass and the diversity

of structures in the stone make each light a unique original. The purity of the natural materials and the artisanship applied in processing them have given rise to a light of extraordinary ambience. Produced using traditional techniques, Macaron is characteristic of the distinctive and enduring aesthetic of the BROKIS brand. Macaron comes in three sizes – the largest of which also makes an attractive floor light – and in several glass colour options with either white or honey onyx. The collection offers an alternate version featuring a centre plate made of BROKISGLASS in combination with a wooden base.

DESIGN

LUCIE KOLDOVA





PH1872



PH12305



MACARON

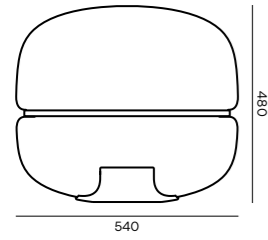

PC1040

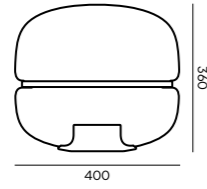

PC1039

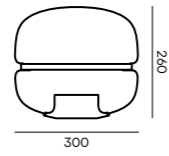

PC1038

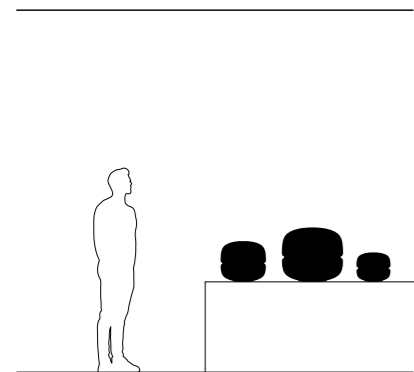

MACARON

GLASS COLOUR

Possible in glossy surface.

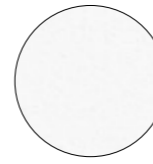

transparent glass

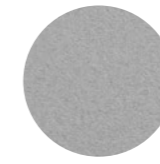

smoke grey -
transparent glass



amber - transparent
glass



light pink -
transparent glass



dark rosé -
transparent glass

SURFACE FINISH OF THE BASE



european oak -
stained white



european oak -
stained black



onyx white



onyx honey

SURFACE FINISH OF THE PLATE

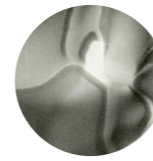

BROKISGLASS -
smoke grey matte



BROKISGLASS -
triplex opal matte



onyx white



onyx honey

CABLE COLOUR

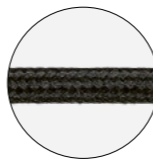

textile cable - black

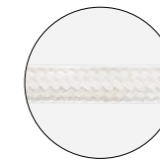

textile cable - white

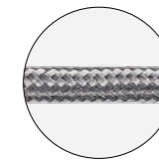

textile cable - dark grey

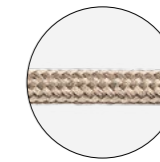

textile cable - light grey

This large-format light with matte core by designer Lucie Koldova embodies a gentle poetry, simplicity, purity, and balanced proportions. A key role is played by the inoculation of luminous bodies and their mutual interaction in space – the light emitted from the smaller glass core flows freely through the atoms of air within the symbolic protective shell of the outer globe, while the sophisticated design of a bubble suspended in a large sphere evokes a sense of levitation. In keeping with the brand's ongoing development of new technologies at the highest levels of quality

DESIGN

and innovation, the Big One collection has received a technological upgrade in the form of a new LED panel that significantly increases the output of the lights. Enhanced metal components simplify handling. The outer glass features a gloss finish in the following colour options: transparent, smoke grey transparent, and smoke brown. The inner glass features a matte finish in the following colour options: triplex opal, smoke grey transparent, red transparent, light pink transparent, and smoke brown. The Big One collection is available in two sizes.

LUCIE KOLDOVA

BIG ONE

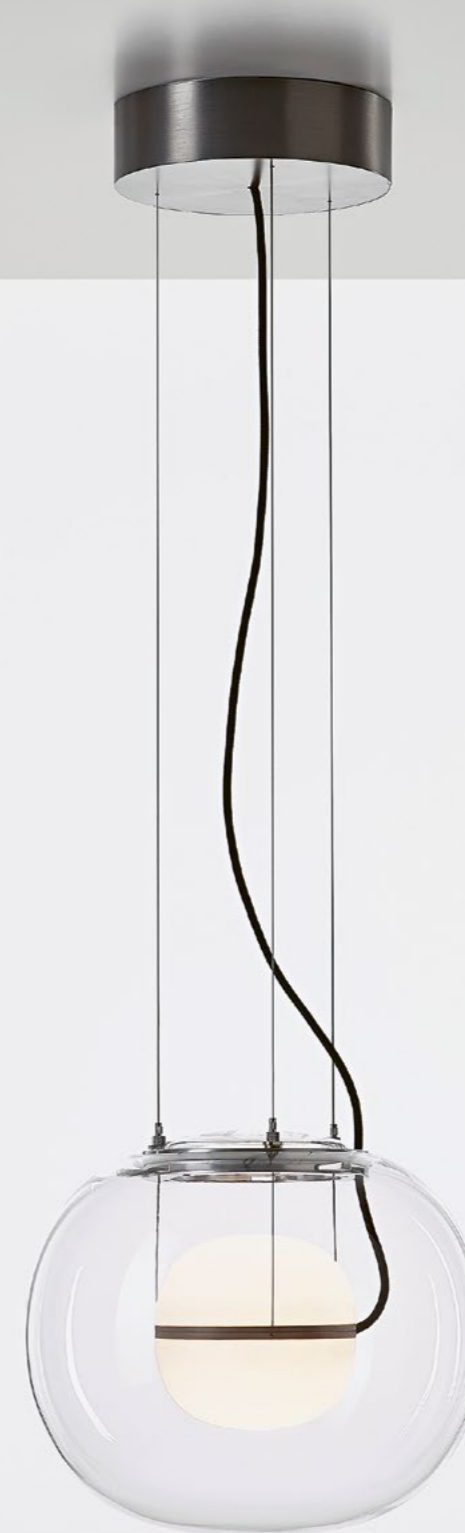





PH12133



PH12339

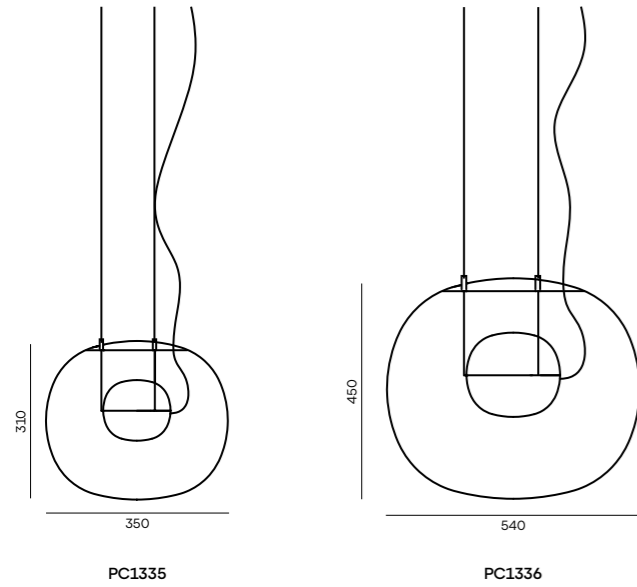

Canopy

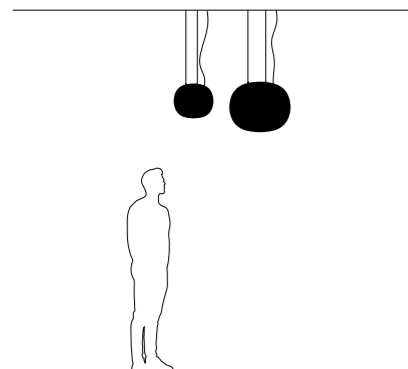
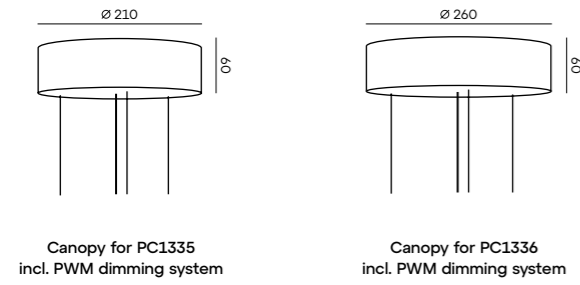

GLASS COLOUR

In glossy surface.

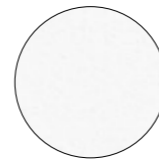

transparent glass

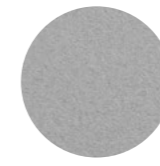

smoke grey – transparent glass



light smoke brown – transparent glass

COLOUR OF THE INNER GLASS

In acid-etched both side surface

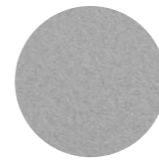

smoke grey – transparent glass



red – transparent glass



light pink – transparent glass

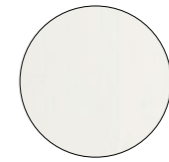

triplex opal

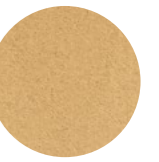

smoke brown – transparent glass

BODY FINISH

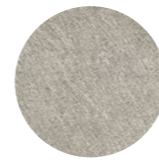

silver anodized

CANOPY

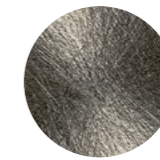

brushed stainless steel

CABLE COLOUR

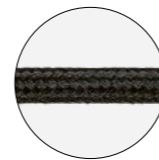

textile cable – black

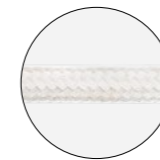

textile cable – white

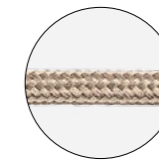

textile cable – light grey

Ivy

Nature and its life-giving beauty and strength are the inspiration behind the unique lighting concept called Ivy. Just as the plant grows and climbs up the wall of a house, so too can Ivy expand into a variety of compositions. The family features a special system of modular components and uses coaxial cables for a highly innovative take on decorative pendant lighting that is easy to install and arrange. The solitary Ivy Single comes in three sizes and is hung separately. The family features metal components in combination with handblown glass. Branches come in six basic sizes, while there are three sizes of shades in handblown matte light rose, triplex opal, or smoke glass. In addition to the pendants, the family

also offers an impressive floor light, distinctive ceiling and wall variants, an intimate table light, and a portable battery-powered light. Elegant and precise in craftsmanship all the way down to the smallest detail, Ivy is a high-tech lighting concept perfect for project and residential applications. In household settings, a single graceful branch can be hung above a dining table, or multiple branches can be used to create a curtain of light. The organic Ivy family takes many forms and rightfully holds its place in the realm of artistic, bespoke lighting solutions. BROKIS has an online configurator to simplify the creation of unique lighting compositions.

DESIGN

LUCIE KOLDOVA



PH:2021





FH753



PH3875



IVY SINGLE

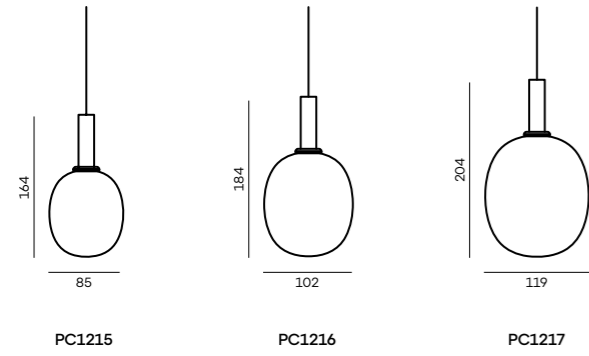

Canopy

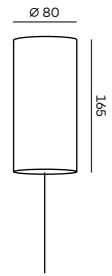

Predefined composition - example

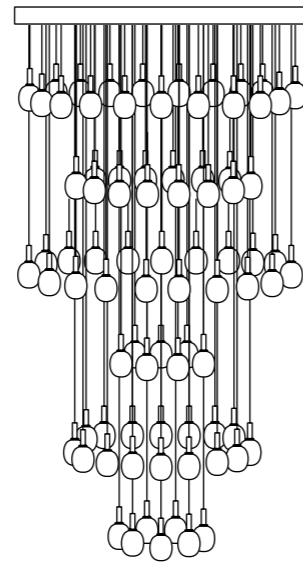

For more predefined or custom compositions visit: configurator.brokis.cz

IVY FLOOR

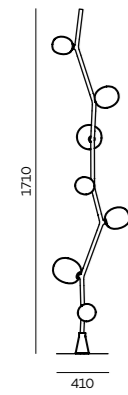

PC1132

IVY TABLE

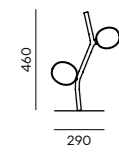

PC1131

IVY HORIZONTAL

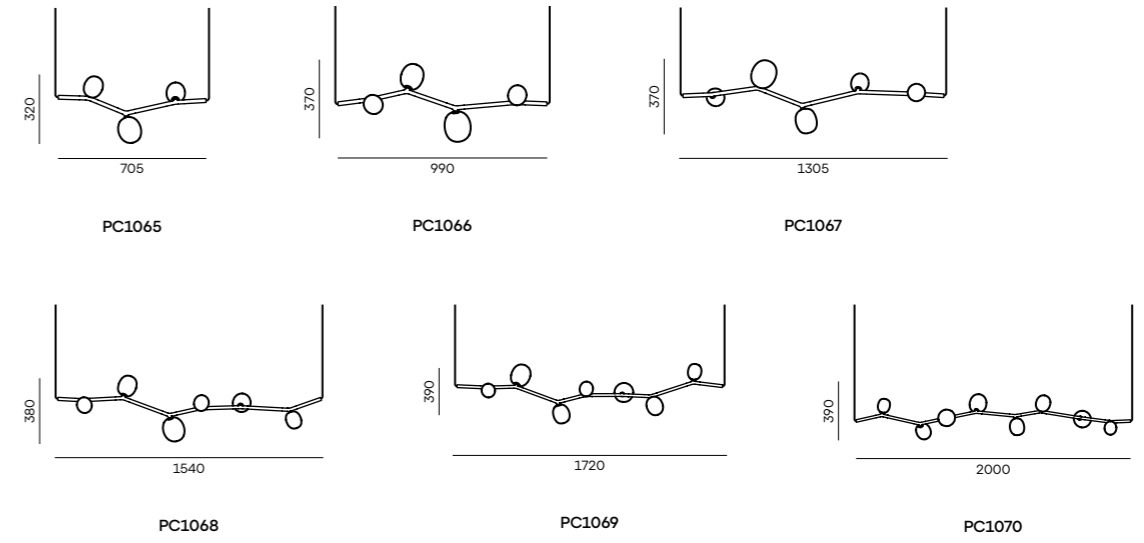

IVY VERTICAL

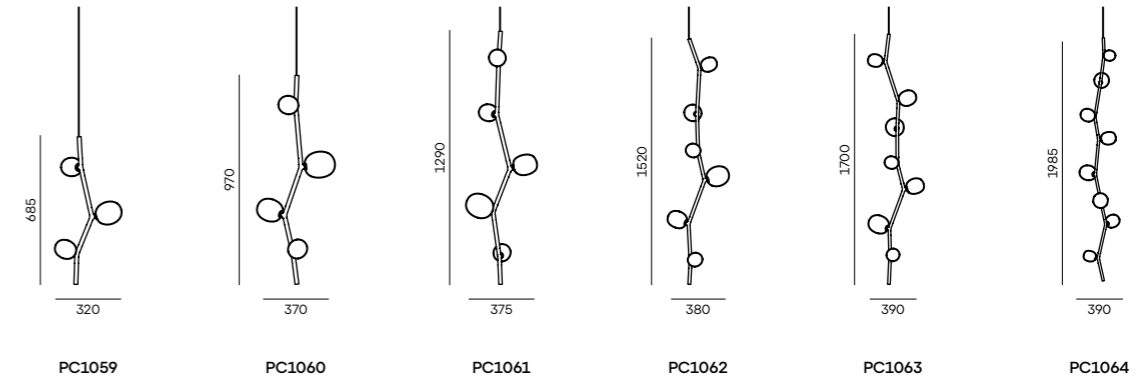

Canopy

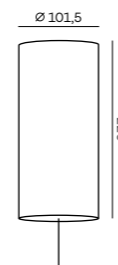

Canopy for dimmable version incl. PWM dimming system

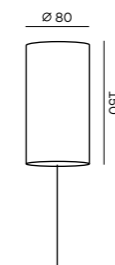

Canopy for non-dimmable version

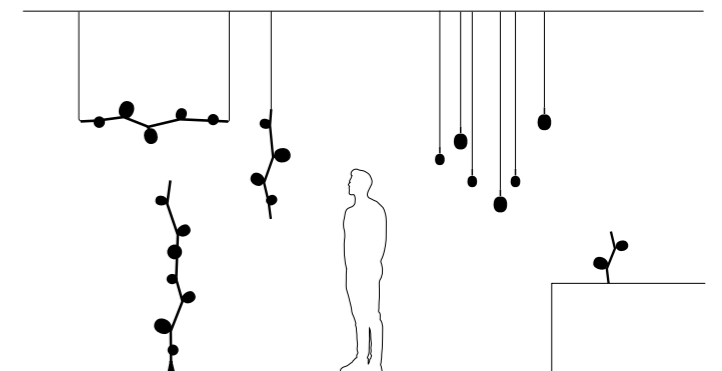

IVY CEILING

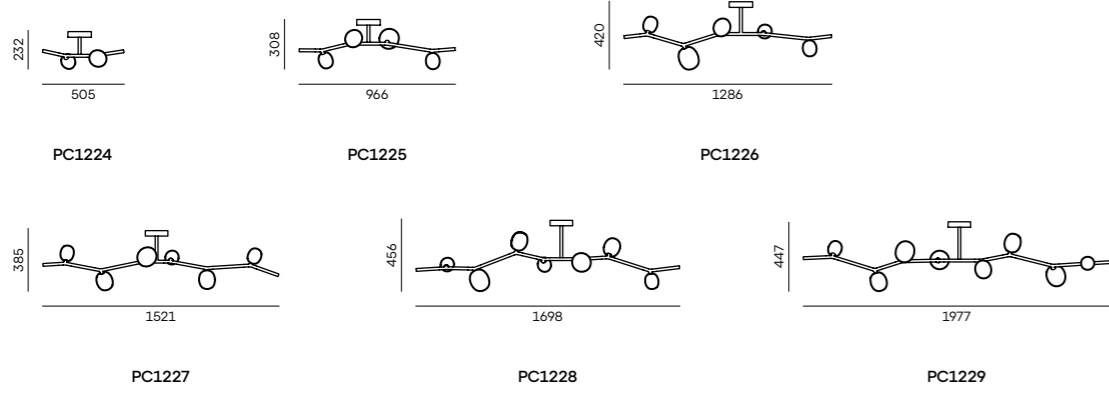

IVY WALL

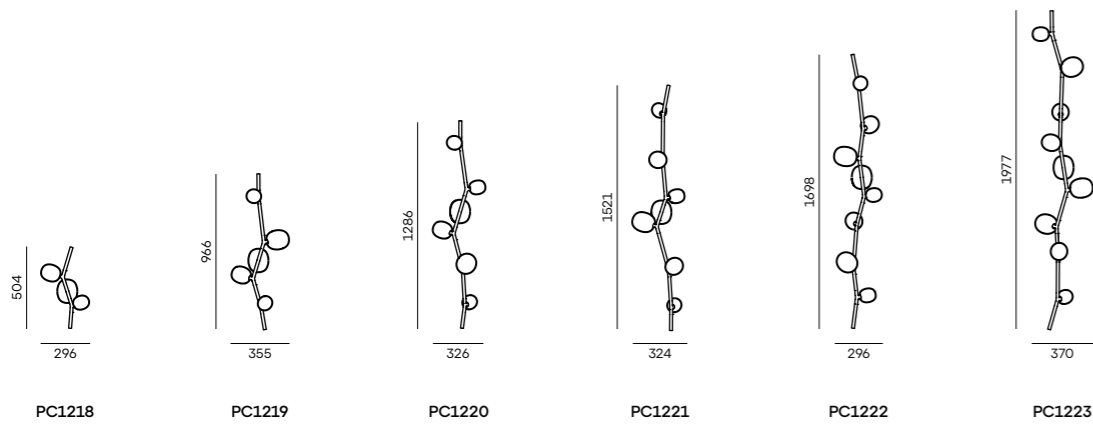

IVY BATTERY

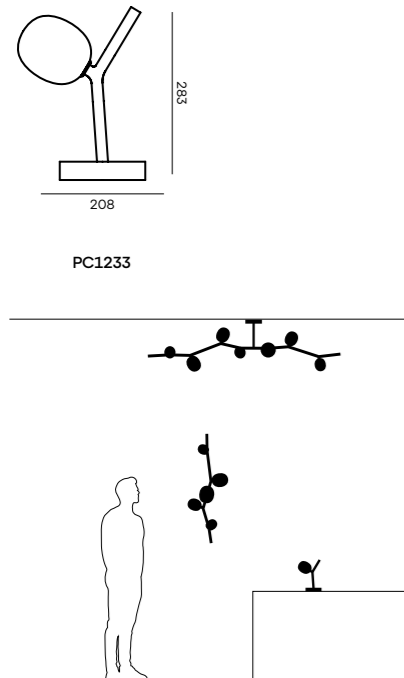

GLASS COLOUR

In acid-etched both side surface.

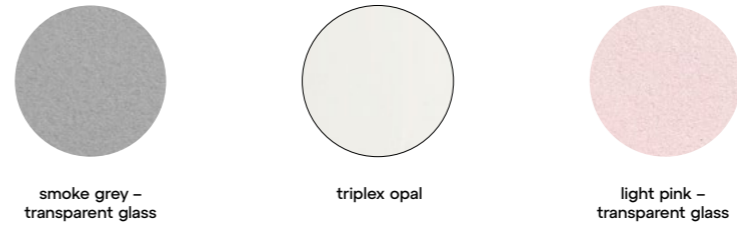

BODY / CANOPY FINISH

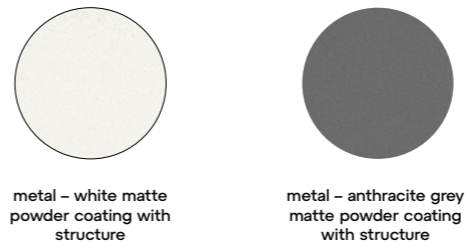

TRIMLESS

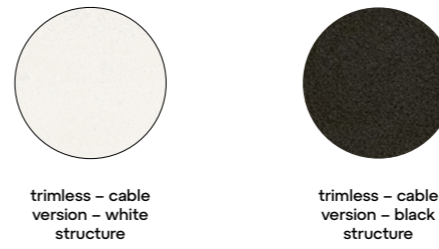

CABLE COLOUR

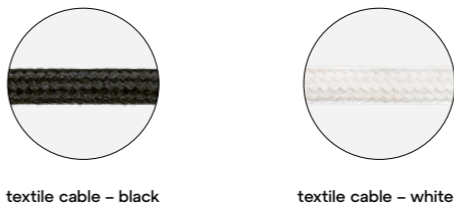

AWWA



In Japanese, the word 'awa' is used to describe a bubble of air trapped within a liquid. The design of this delicate light was inspired by the notion of soft glass that has retained its shape after being inflated. The aim is to give the impression of a luminous ball of air floating gently in space when viewed from below.

DESIGN

Another special characteristic of the design is that the wood and metal parts appear to be made of glass, as if they were stoppers keeping the air from escaping. A recent addition to the collection is a version featuring frosted glass in the top half of the light.

FUMIE SHIBATA





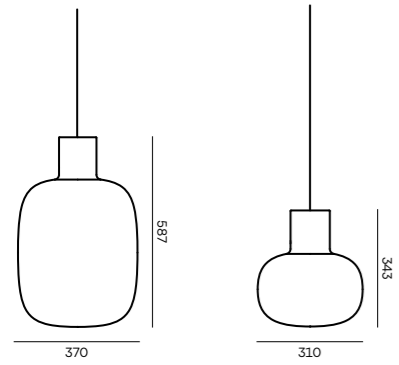

PC1130

PC1129

Canopy

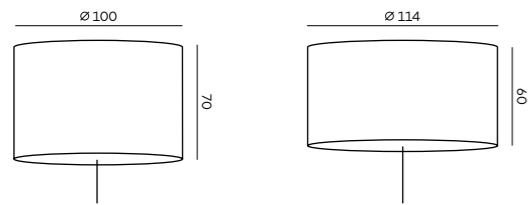

Metal canopy

Wooden canopy

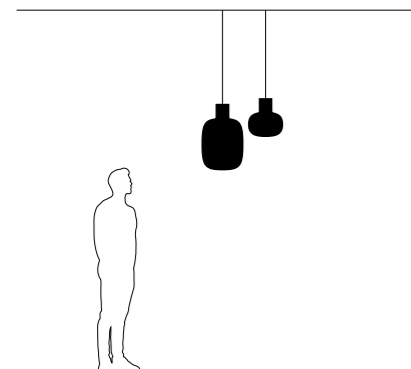

GLASS COLOUR

Possible in glossy surface and glossy - sandblasted (top part).

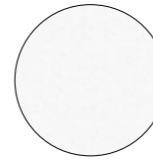

transparent glass

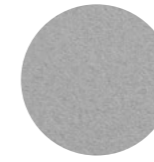

smoke grey - transparent glass

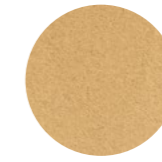

smoke brown - transparent glass

BODY / CANOPY FINISH



copper

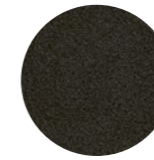

metal - black matte powder coating with structure



european oak - natural lacquer (wax)



american walnut - natural waxed



brushed champagne lacquer

TRIMLESS



trimless - cable version - white structure

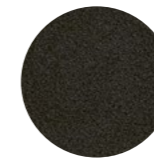

trimless - cable version - black structure

CABLE COLOUR

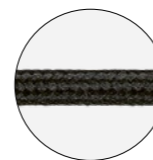

textile cable - black

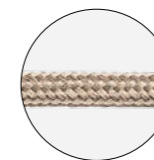

textile cable - light grey

BONBORI



The very first outdoor light in the BROKIS portfolio, Bonbori was created by world-renowned Japanese designer Fumie Shibata, who took inspiration from the traditional paper lamps that line the paths to shrines and temples during the annual paddy harvest festivals in Japan. In Japanese, the word 'bonbori' not only denotes this traditional form of illumination, but it also describes the soft light coming from within a snowy cave. Manufactured with an IP44 rating for outdoor use, the light stands upon a simple stainless-steel base with weather-resistant powder coating. The easily removable LED light source, which can

withstand below-freezing temperatures, casts its gentle glow through a handblown triplex opal diffuser and laser-cut openings in the stainless steel. The likeness to the traditional bonbori lamp is completed with an elegant shade, an extraordinary piece crafted from multiple layers of carefully blown glass. Bonbori now also comes in a dedicated wall variant and a portable interior variant. Whether in the garden, on the terrace, or inside the home, the soothing light of Bonbori pays tribute to a Japanese tradition by creating a unique and festive ambience to be enjoyed as thoroughly in solitude as with family and friends.

DESIGN

FUMIE SHIBATA



PH3794

PH7466





archiproducts

 DESIGN AWARDS

 WINNER 2020



PH2562





PH3864

BONBORI

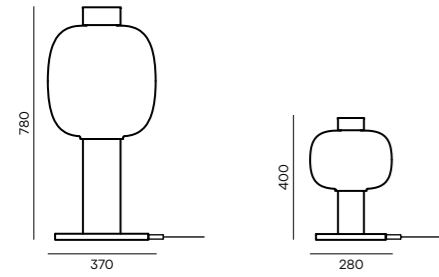

PC1165

PC1164

BONBORI OUTDOOR

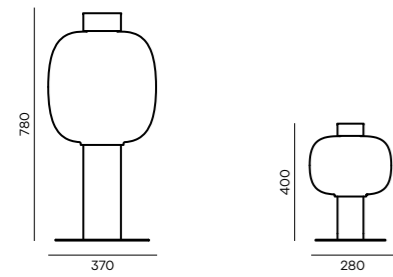

PC1167

PC1166

BONBORI WALL

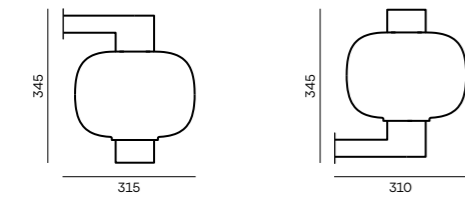

PC1280

PC1251

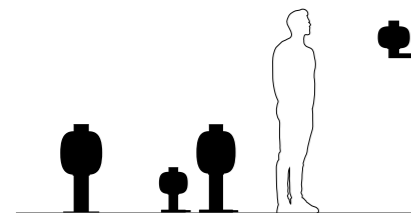

BONBORI

GLASS COLOUR

In glossy surface.

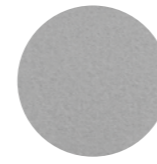

smoke grey - transparent glass

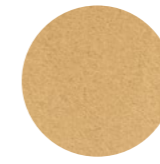

smoke brown - transparent glass

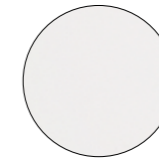

opaline - transparent glass

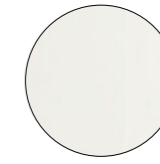

triplex opal



olive green - transparent glass

BODY FINISH

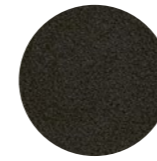

metal - black matte powder coating



copper metallic

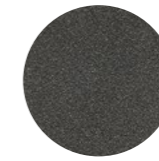

grey metallic

CABLE COLOUR

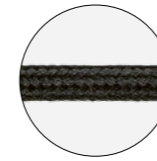

textile cable - black

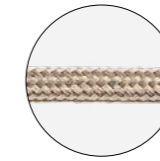

textile cable - light grey

The Sfera family offers three shapes and several sizes of lights designed to meet the needs of demanding projects and the architects and other professionals behind them. The prevailing characteristic of the Sfera project light is a clean cut across the top that serves as a platform for an elegant decagonal fixture. The timeless object casts a gentle luminance through handblown matte opal glass, which is attached to a metal plate with a subtle multangular detail. The sphere is crafted in eight sizes (150 to 600 mm), and a practical BROKIS connector facilitates installation and cleaning. The universal beauty and simplicity of the Sfera family mean it can be used in any space and in any number, from a single light as an elegant accent, to large bespoke compositions

DESIGN

of different shapes and sizes. A later addition to the family is Sfera Portable, a rechargeable outdoor light. Available in two sizes, it features a small sphere of handblown matte or gloss glass set within a concrete base with the same subtle multangular detail used throughout the family. A stainless-steel hoop serves as a handle for moving the light from one place to another. Handblown glass anchored in a raw, almost brutalist concrete base is an excellent match for modern architecture, but it can also be used to great effect when set in contrast with historical buildings. Sfera Portable is a stylish atmospheric lighting object designed for both outdoor and indoor applications.

LUCIE KOLDOVA

SFERA



PH17392







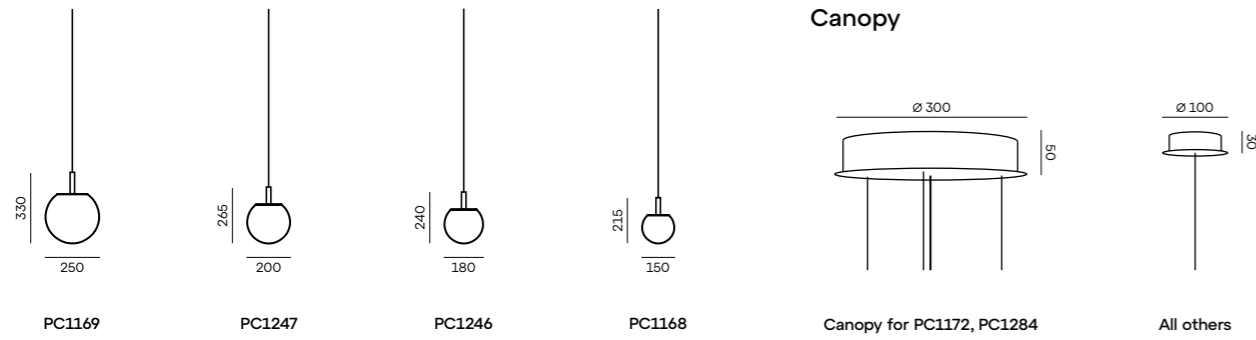
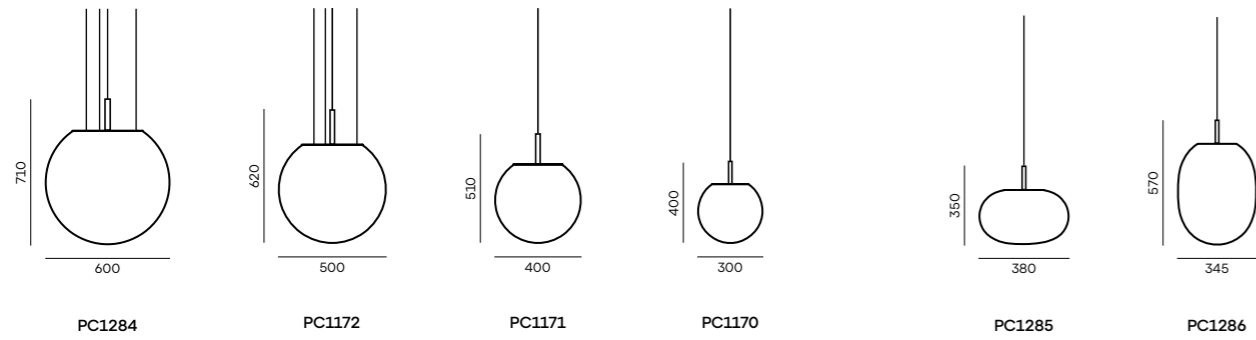

SFERA PORTABLE

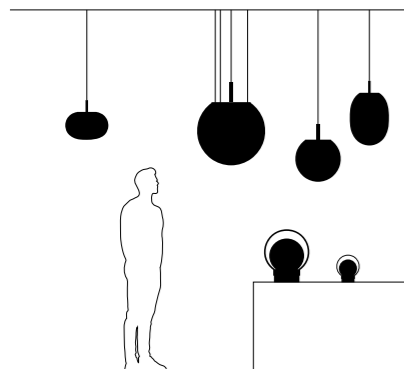
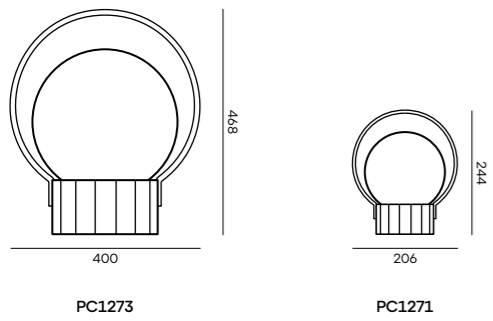

GLASS COLOUR

Possible in glossy surface, acid-etched both side surface and acid-etched outside surface.



BODY / CANOPY FINISH

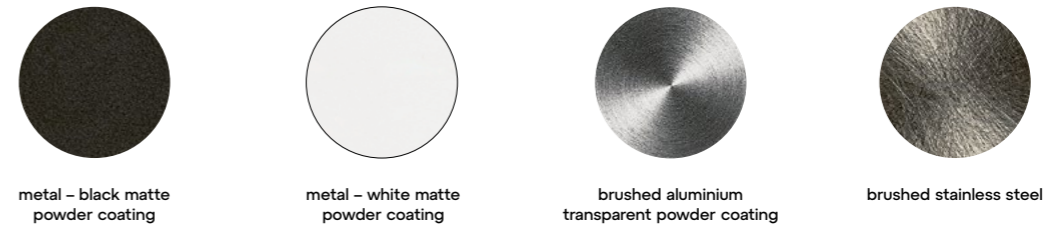

BASE FINISH

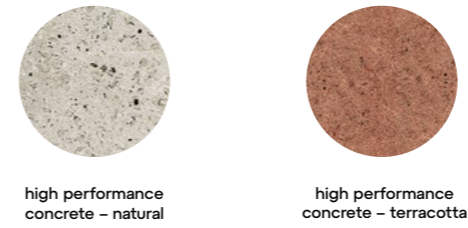

TRIMLESS

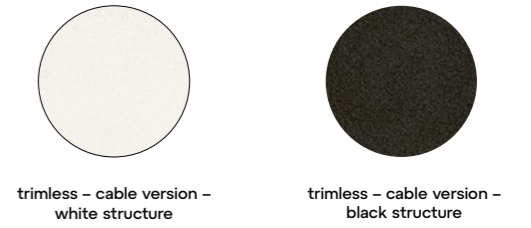

CABLE COLOUR

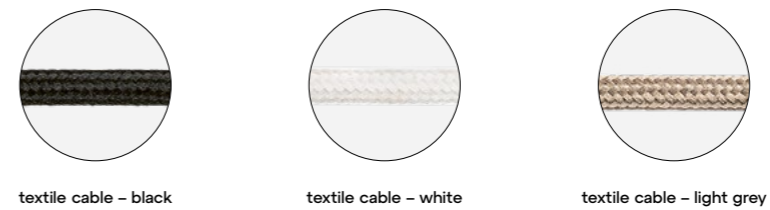

The materials library serves only to provide a general overview of the variants offered within a given collection. For further specification or verification of possible restrictions on individual combinations of colours and/or materials for the product you have selected, please use other sales instruments, such as the Product Sheet, Price List, MyBrokis, etc.

Geometric accentuates the aesthetic expression and structure of BROKISGLASS, which itself is remarkably distinctive. The collection is defined by basic geometric shapes that characterize the overall contours of the lights and instil them with a singular graphic element to achieve a striking contrast with the animate, almost sculptural makeup of the glass. The suspension components comprise glass geometric shapes, their edges rendered in black profiles. The circular and oval lights work well as solitary pieces, and multiples can also be arranged in a sort

of jigsaw puzzle, which in the hands of architects results in an endless variety of lighting combinations. The concept surpasses its primary function as a lighting fixture and opens the door to large-format blocks of light and other uncommon compositions. For even more expressive freedom and a truly bespoke lighting experience, clients can specify a different colour of glass in each of the two sections of a light. Resting against a sturdy cylindrical base, the Geometric Table elicits a subtle aesthetic tension that amplifies the overall visual experience.

DESIGN

BORIS KLIMEK, LENKA DAMOVÁ



GEOMETRIC







PH5646



PH12131

GEOMETRIC

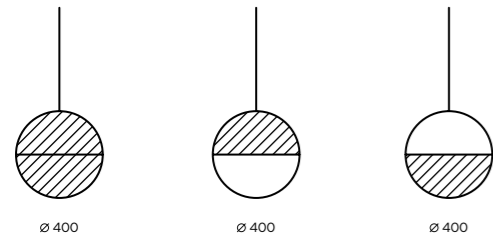

PC1140 PC1141 PC1142

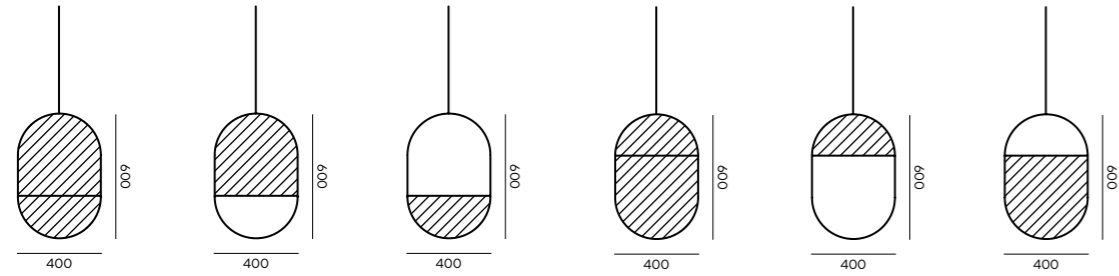

PC1143 PC1144 PC1145 PC1146 PC1147 PC1150

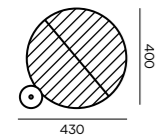

PC1270

Canopy

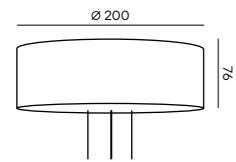

Incl. PWM dimming system

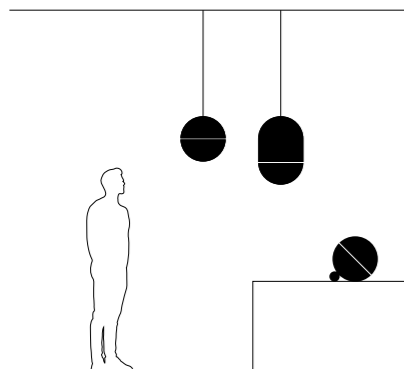

GEOMETRIC

TOP / BOTTOM BROKISGLASS COLOUR

Possible in glossy finish (front face) and acid-etched finish (front face).



triplex opal BROKISGLASS

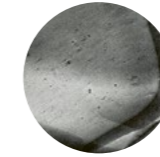

smoke grey BROKISGLASS



smoke brown BROKISGLASS



yellow – triplex opal BROKISGLASS



light pink – triplex opal BROKISGLASS



orange – triplex opal BROKISGLASS



red – triplex opal BROKISGLASS



light blue – triplex opal BROKISGLASS



turquoise – triplex opal BROKISGLASS



dark green – triplex opal BROKISGLASS



green apple – triplex opal BROKISGLASS



amber – triplex opal BROKISGLASS



cognac – triplex opal BROKISGLASS



grey – triplex opal BROKISGLASS

BODY / CANOPY FINISH

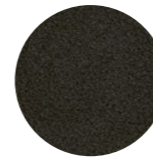

metal – black matte powder coating with structure

CABLE COLOUR

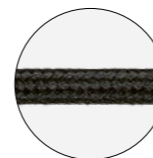

textile cable – black

The Planets collection is based on period lights and reflects the daily needs not only of customers but of architects and designers too. Thanks to a simple physical principle, the lights can be variably positioned in diverse arrangements. The use of weights and pulleys makes it possible to quickly adjust the height of the lights, a unique system that allows for several groupings to serve as individual sources of light in an interior, or as multiples of three different (or same) shapes to illuminate larger spaces. The counterweight is precisely calibrated to the specific weight of the light, so adjustments are safe and easy. A round LED panel is situated beneath a shade of matte glass, which conceals the internal

DESIGN

parts and thus preserves the silhouette of the light. The metal components also come in a matte finish and are combined with a textile cord for a uniform look. The colour scheme is always monochromatic to underline the graphic character of the lights, and the glass shades are rendered in elementary geometric shapes – sphere, cone, and capsule. The Planets collection stands out with its remarkable versatility, offering a broader dimension in interior lighting with installations ranging from a single light to vast clouds of up to twelve lights. The Planets family has been expanded with a new version called Planets MINI. BROKIS has online configurators to simplify the creation of unique lighting compositions.

VRTIŠKA & ŽÁK



PLANETS





PH5700



PH5712



PH5663

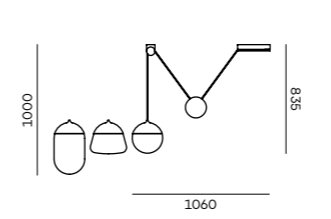

PC1234

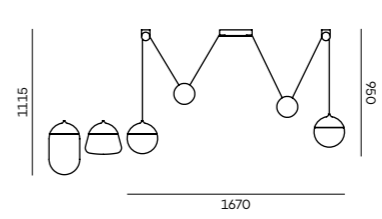

PC1235

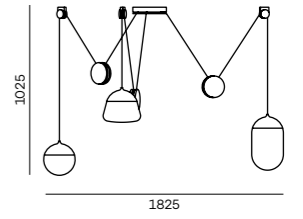

PC1236

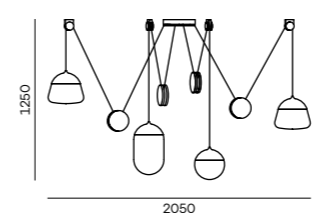

PC1237

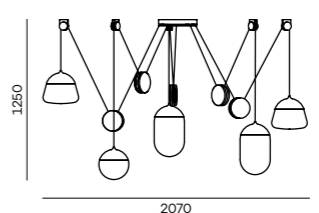

PC1238

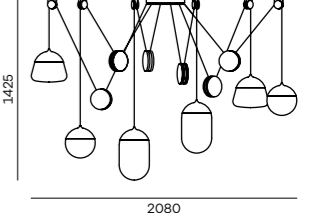

PC1239

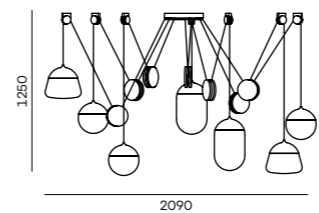

PC1240

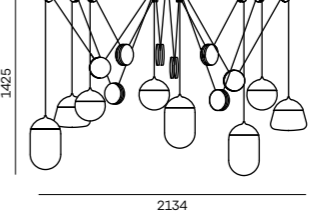

PC1241

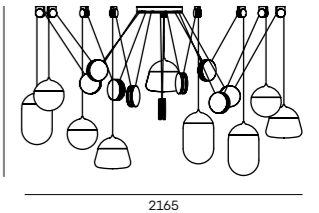

PC1242

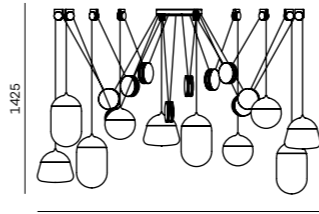

PC1243

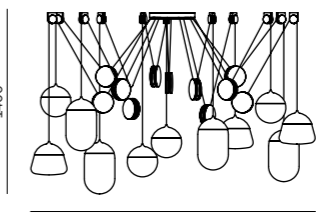

PC1244

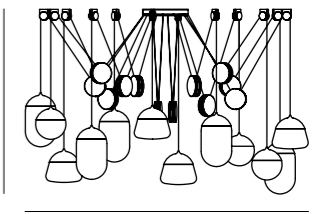

PC1245

Canopy

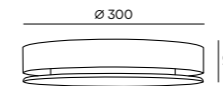

Canopy for PC1234-PC1236

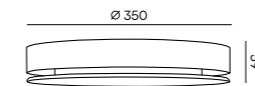

Canopy for PC1237-PC1241

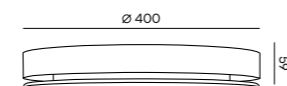

Canopy for PC1242-PC1245

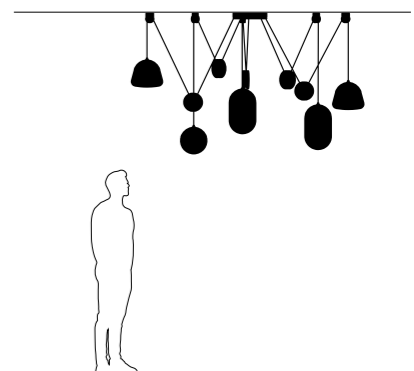

PLANETS MINI

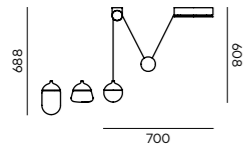

PC1359

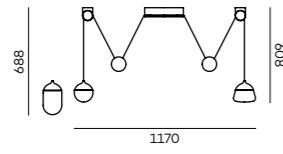

PC1360

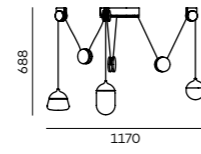

PC1361

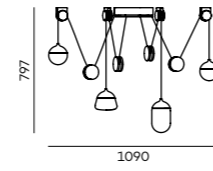

PC1362

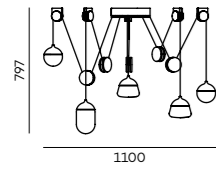

PC1363

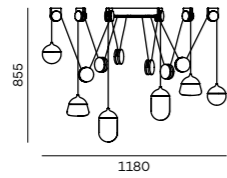

PC1364

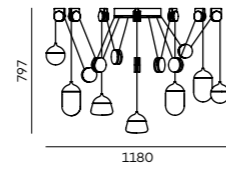

PC1365

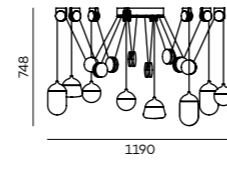

PC1366

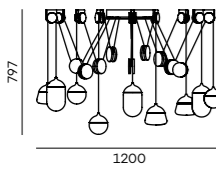

PC1367

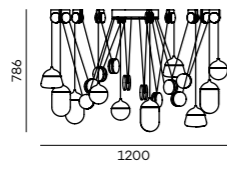

PC1368

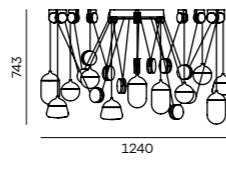

PC1369

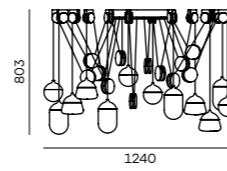

PC1370

Canopy

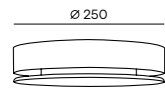

Canopy for PC1359-PC1363

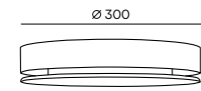

Canopy for PC1364-PC1368



Canopy for PC1369-PC1370

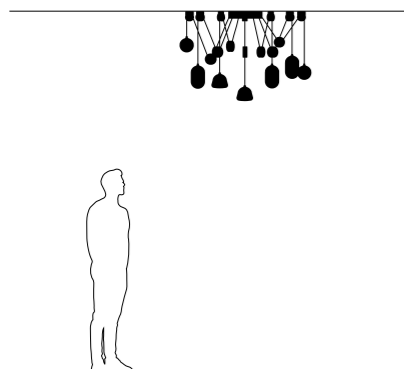

GLASS COLOUR

In acid-etched both side surface.

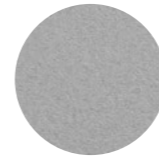

smoke grey - transparent glass

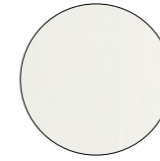

triplex opal

BODY FINISH

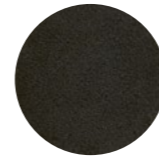

metal - black matte powder coating with structure



metal - white matte powder coating with structure

CABLE COLOUR

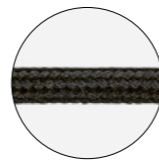

textile cable - black

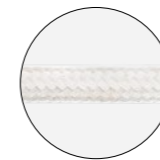

textile cable - white

The materials library serves only to provide a general overview of the variants offered within a given collection. For further specification or verification of possible restrictions on individual combinations of colours and/or materials for the product you have selected, please use other sales instruments, such as the Product Sheet, Price List, MyBrokis, etc.

The Orbis collection is based on a universal shape rendered in handblown smoke glass that has been abruptly severed across the top to accommodate an elegant multangular metal fixture. Rich in ambience yet enticingly minimalist, these atmospheric lights embody a sense of technicism. A diffuser conceals an LED panel within the fixture and softens the light as it radiates outwards from its source, while the multiangle serves to house a special BROKIS connector engineered for easy installation and arrangement of grand lighting compositions.

DESIGN

Additional variability is provided by a choice of subtle grey smoke glass, with the metal fixture finished in a black powder coating that underscores the gloss of the transparent glass. These refined components come together to create an unmistakable interior charm well suited to large restaurant and hotel spaces as well as intimate private interiors. Available with glass in one of several colour options, each of which is paired with metal components in a predetermined corresponding colour.

LUCIE KOLDOVA



ORBIS



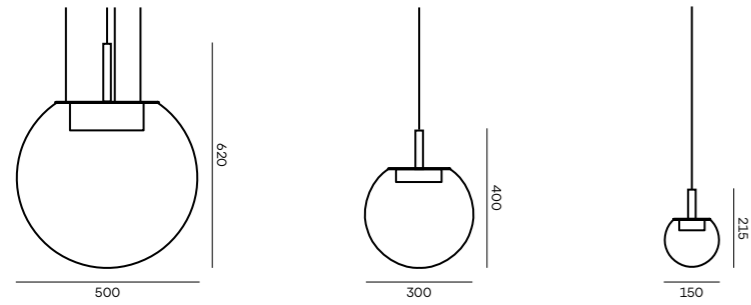

PC1291

PC1290

PC1289

Canopy

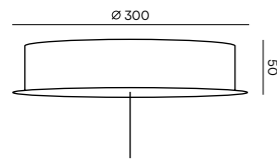

Canopy for PC1291
incl. PWM dimming system

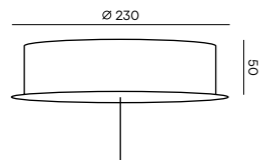

Canopy for PC1289, PC1290
for PWM dimming system

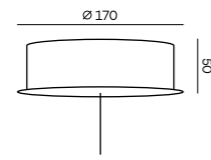

Canopy for PC1289, PC1290

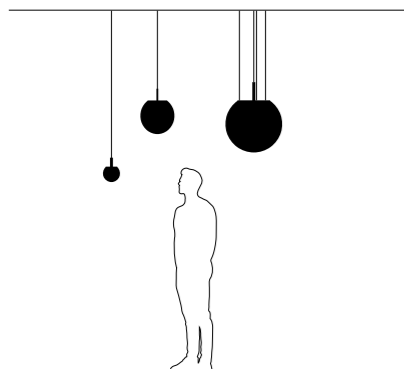

GLASS COLOUR

In glossy surface.

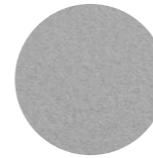

smoke grey –
transparent glass

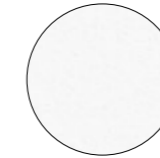

transparent glass



light pink –
transparent glass



amber – transparent
glass



light smoke brown –
transparent glass

BODY / CANOPY FINISH

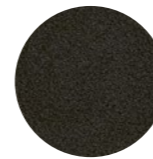

metal – black matte
powder coating



metal – grey-beige matte
powder coat



metal – pink matte
powder coating



metal – okra matte
powder coating



metal – khaki matte
powder coating

TRIMLESS



trimless – cable version –
white structure

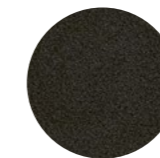

trimless – cable version –
black structure

CABLE COLOUR



textile cable – black

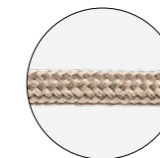

textile cable – light grey

The materials library serves only to provide a general overview of the variants offered within a given collection. For further specification or verification of possible restrictions on individual combinations of colours and/or materials for the product you have selected, please use other sales instruments, such as the Product Sheet, Price List, MyBrokis, etc.

DOUBLE

Double, a collection of elegant pendent lights, is based on a shape comprising double elements crafted from different materials – glass and light-weight aluminium. These materials depend on one another to generate a unique and consonant form. The glass globe terminating in a metal ring provides a suggestive effect, with the handle on top alluding to the idea of portability. In the pendent variant, which is available in three different shapes, the upper metal section with wire rope seeks equilibrium in

the scattered light and shadows as they pass through the lower metal ring and globe, while the latter consists of multiple layers of molten glass that are carefully scrutinized by the master glassmaker prior to blowing. The luminance of the LED light source is softened by a diffuser. By virtue of its scope, the Double collection is ideal for private interiors and works very well in large compositions and colour combinations. The collection has been expanded with table and floor variants.

DESIGN

LCM MARIN DESIGN STUDIO





PH10084



PH8179



PH8179

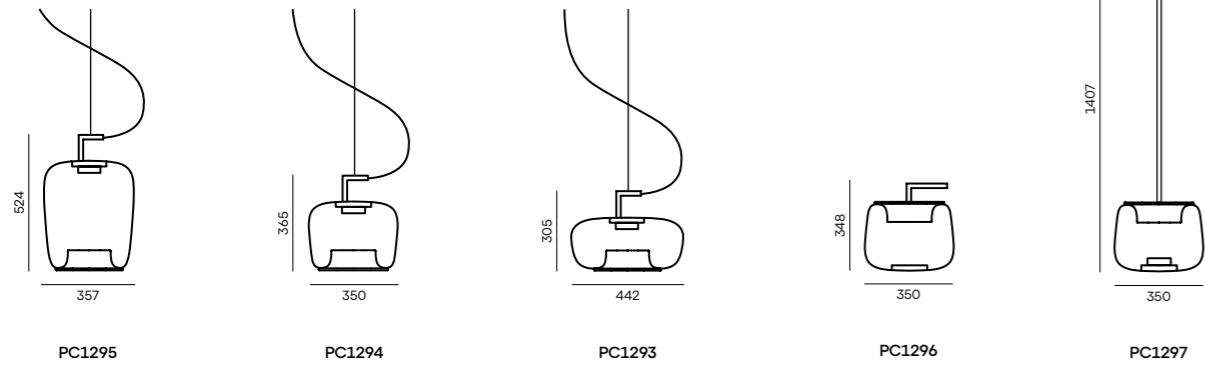

Canopy

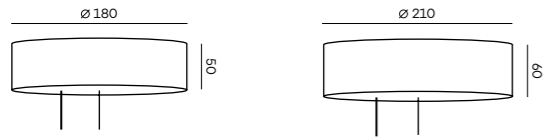

Canopy for PWM dimming system

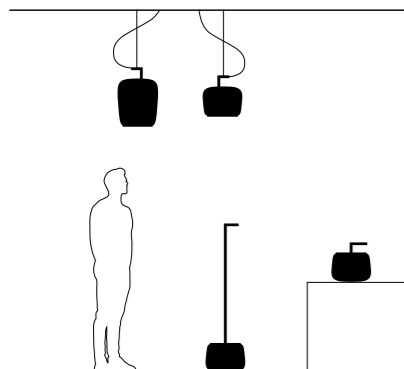

GLASS COLOUR

In glossy surface.

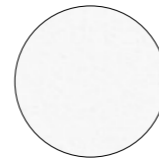

transparent glass

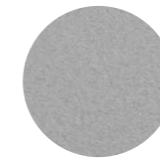

smoke grey - transparent glass



light pink - transparent glass

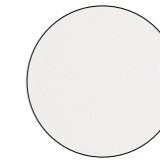

amber - transparent glass

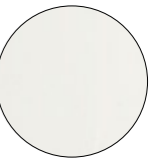

light smoke brown - transparent glass



olive green - transparent glass

BODY / CANOPY FINISH

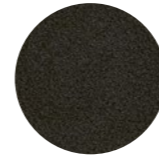

metal - black matte powder coating with structure

CABLE COLOUR

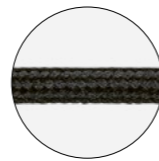

textile cable - black

Modern yet timeless. Extravagant in its style and use of clean geometric forms. Inspired by architecture. The Overlay collection arose from a synthesis of various materials on mood boards during a creative process that involved seeking ideas and associations between art and design, overlaying different textures, and playing with volumes. The blown transparent glass tubes instil the Overlay collection with a distinctive character, as does the unique concrete fixture embedded with shards of upcycled glass from Janštejn Glassworks. The piece is cast in different

rectangular volumes specifically for each type of light capable of accommodating both simple and multiple assemblies for a remarkable degree of versatility. Cradled within the concrete fixture is a delicate sleeve of either frosted or clear glass, its centreline struck by a light tube that seemingly levitates within. The typology of the Overlay collection comprises horizontal pendant variants, table lights, and wall lights that open the door to a new realm of possibilities in lighting art. The collection has now been expanded with other variants.

DESIGN

LUCIE KOLDOVA



OVERLAY



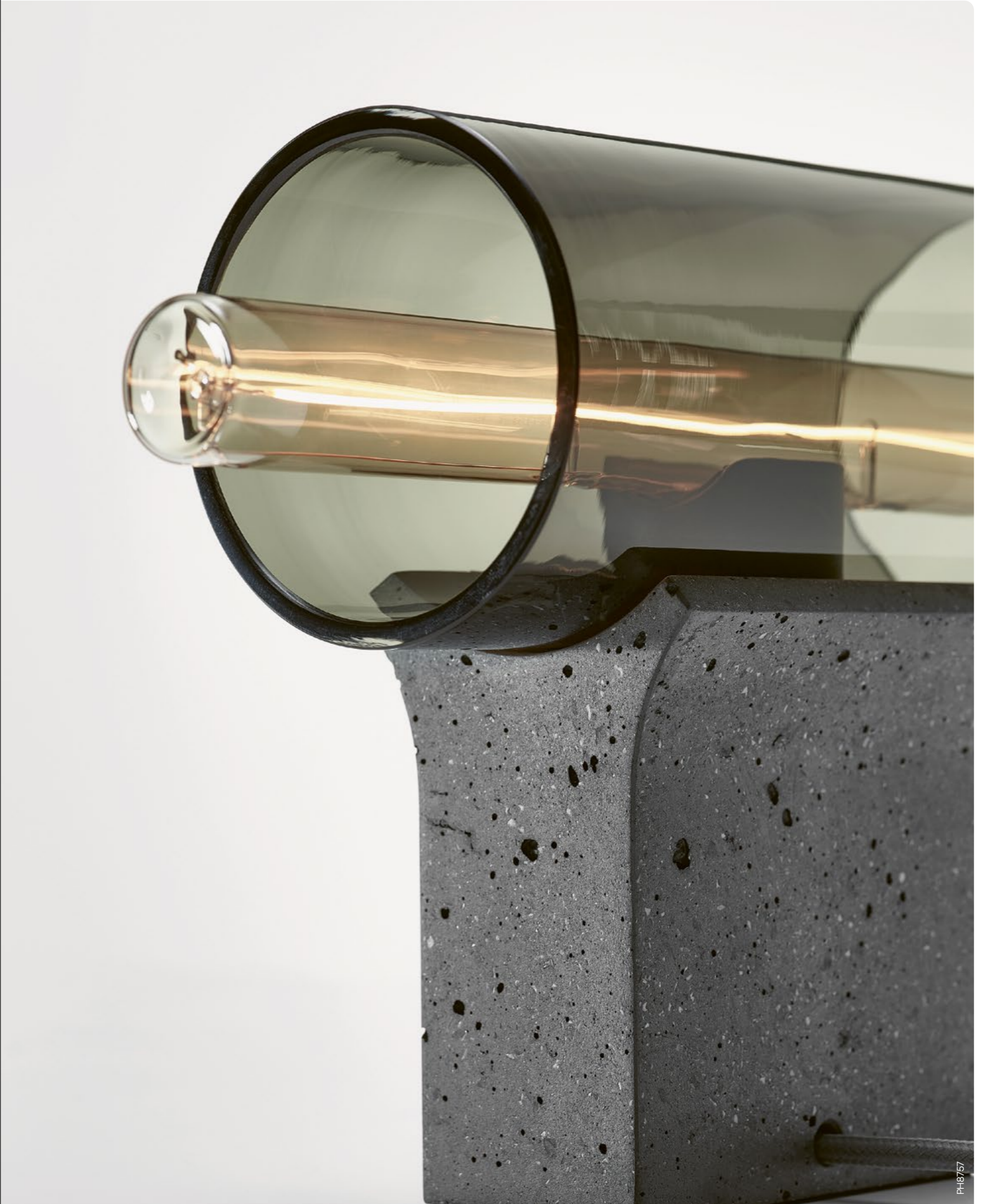
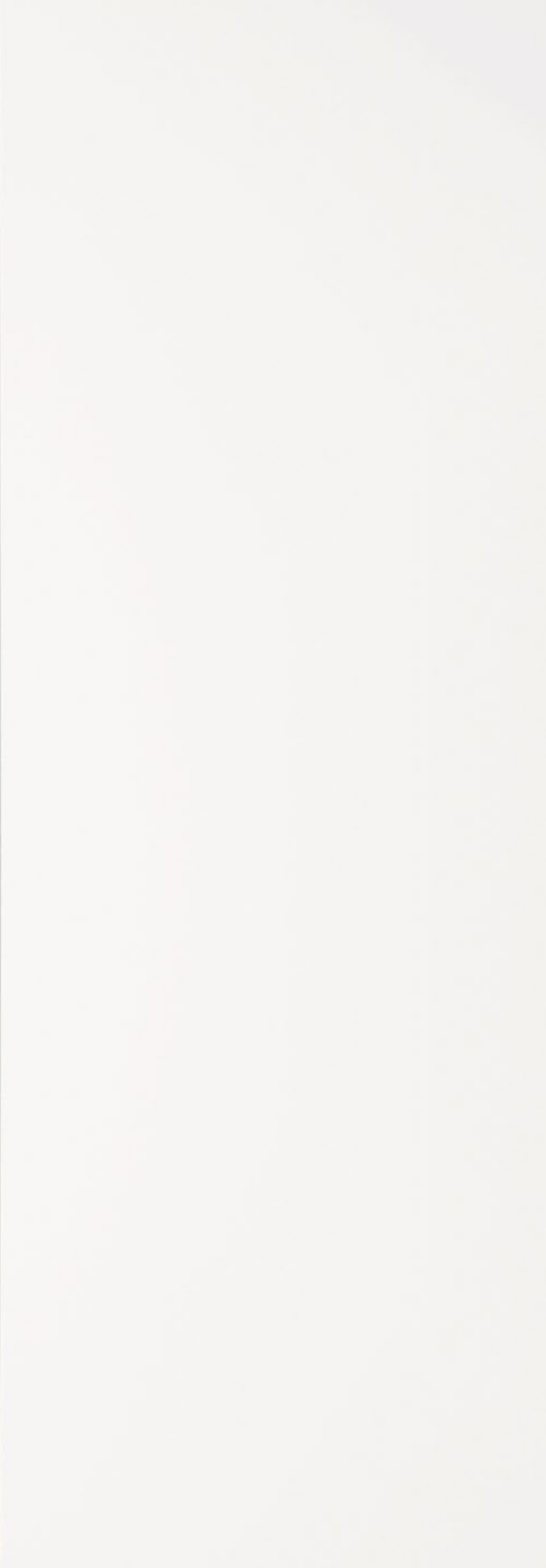

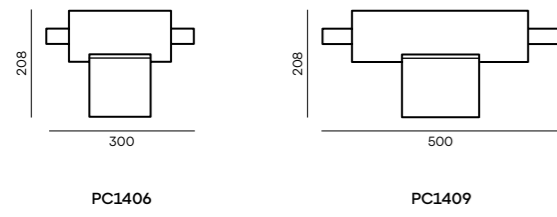
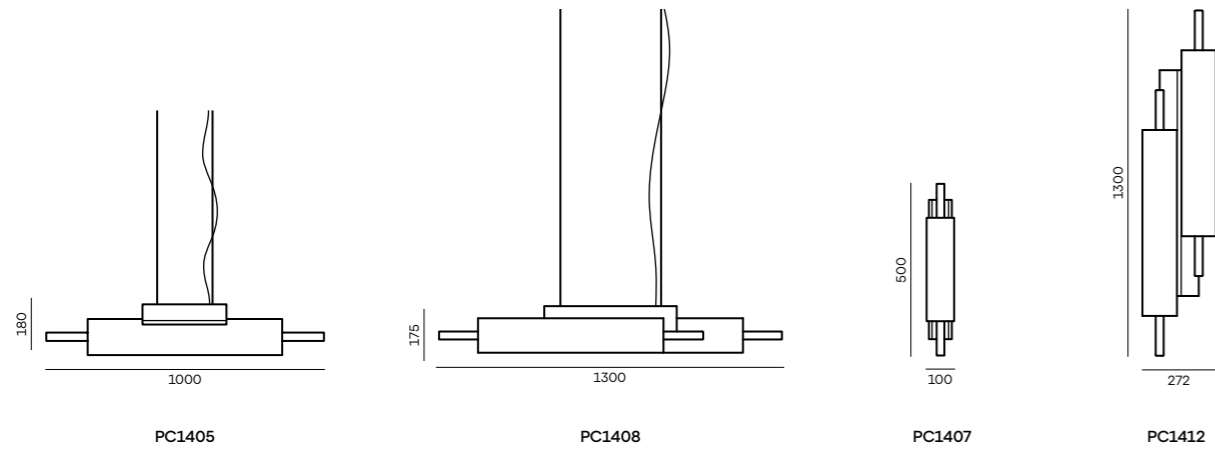

Canopy

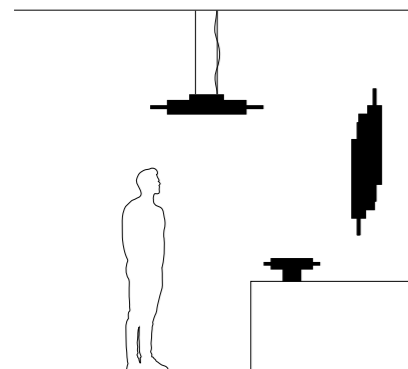
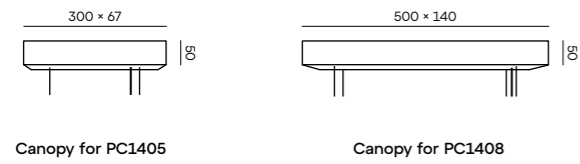

GLASS COLOUR

Possible in glossy surface and acid-etched outside surface.

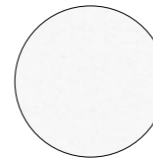

transparent glass

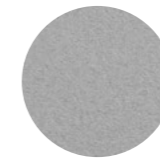

smoke grey - transparent glass



amber - transparent glass



olive green - transparent glass

BODY / CANOPY FINISH

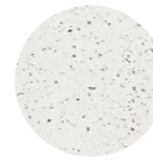

High-performance concrete with glass fragments - white

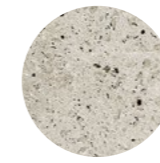

High-performance concrete with glass fragments - natural

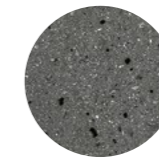

High-performance concrete with glass fragments - anthracite

CABLE COLOUR



textile cable - white

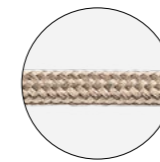

textile cable - light grey

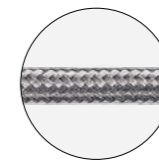

textile cable - dark grey

PRISMA

The dominant feature of the Prisma collection is an extravagant metal fixture with a distinctive finish. Classic handblown glass spheres are anchored to either one or both ends of a robust decagonal metal prism that lends the collection its name. The shape in combination with the striking surface reflect light at different and unexpected angles, like a prism. With a choice of three different elegant finishes – yellow zinc lacquer, brushed steel lacquer, and a new burnished black lacquer, the light is a bold artistic object in the interior offering unique vertical, horizontal, and diagonal compositions with subtle colourful

DESIGN

reflections. The collection consists of a horizontal pendent light with dual glass spheres and a vertical pendent light with a single glass sphere, both of which hang from wire ropes. Another typological variant is an impressive floor light, a majestic light sculpture in the form of a robust upright decagon topped with a luminous glass sphere. The structured finish on the metal fixture is one of the defining traits of the collection, and together with transparent glass or grey smoke glass constitutes a jewel with which to adorn private interiors as well as hotels and restaurants.

LUCIE KOLDOVA



PH14264





PH2100



PH2100

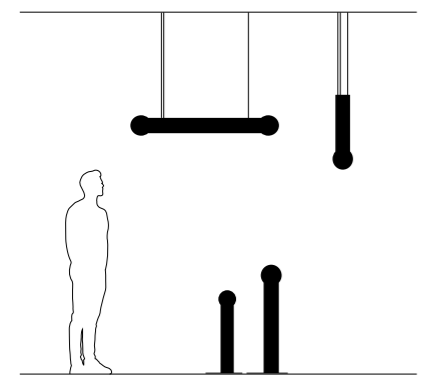
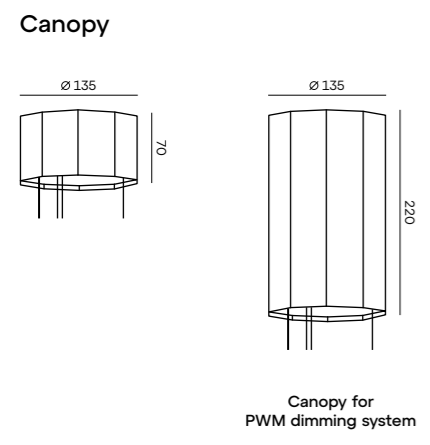
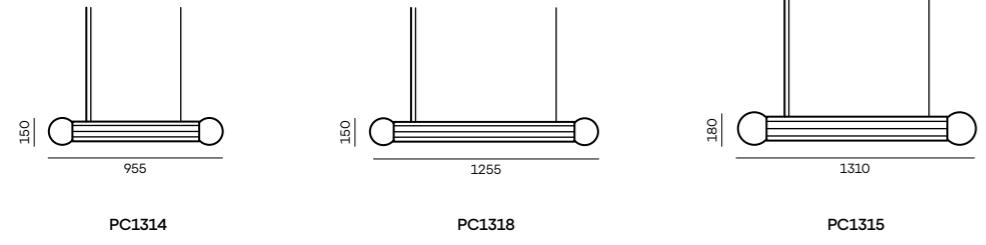
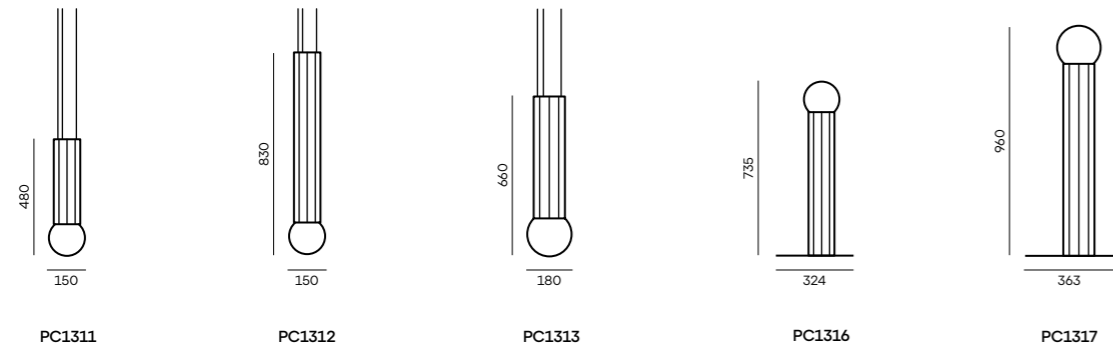

GLASS COLOUR

Possible in glossy surface.

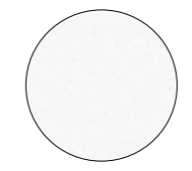

transparent glass



smoke grey - transparent glass

BODY/CANOPY FINISH



yellow zinc lacquer



burnished black lacquer

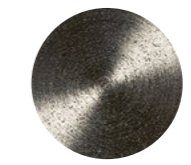

brushed steel lacquered

CABLE COLOUR

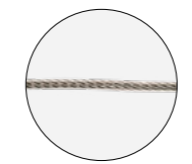

coaxial cable - silver

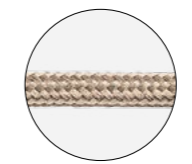

textile cable - light grey

Bamboo Forest draws inspiration from the vertical contours rising up in stands of bamboo. Conceived to evoke a unique atmospheric ambience, the hand-sculpted glass forms a bamboo stalk complete with the typical nodal ring, where the material thickens, creating a soft accent in the form of subtle shadows. With different sizes and varying positions of the node on the stalks, thanks to which the origins of the collection are at once recognizable, compositions of multiple lights transform the interior into a sanctuary replete with the soothing tranquility of a natural

DESIGN

bamboo forest. The innovative BROKIS connector enhances the overall variability of the lights by simplifying not only installation of large sets but also maintenance and cleaning. Bamboo Forest is unique for the unusual shape of the lights, which come in six different variants, as well as for the possibilities the collection offers in creating both original combinations and single-point accent lighting in interior spaces. Larger compositions can be easily designed in the BROKIS online configurator.

FUMIE SHIBATA



PH15637

BAMBOO FOREST







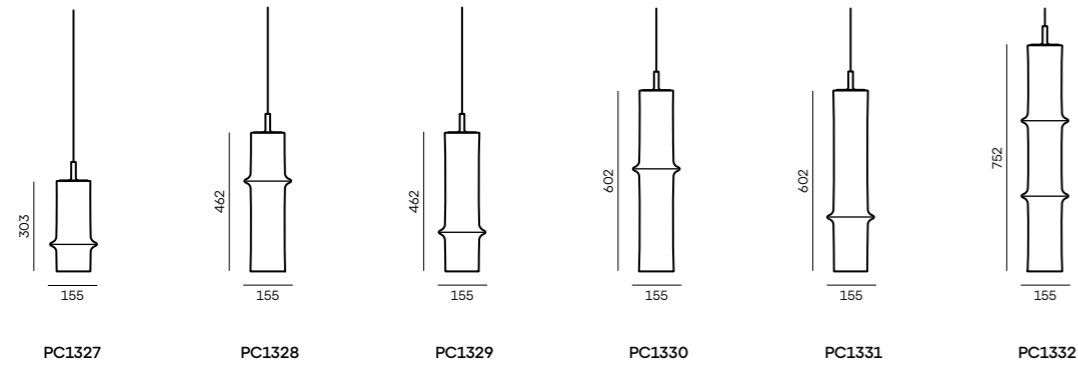

Canopy

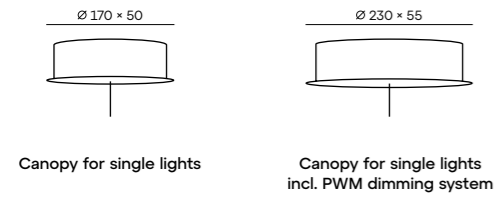

Predefined composition – example

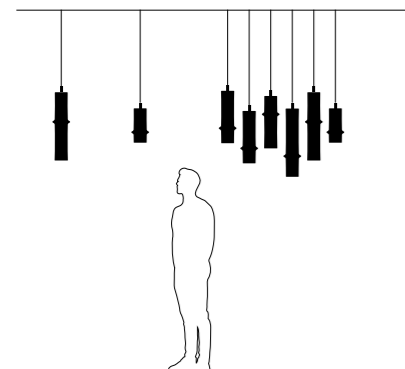
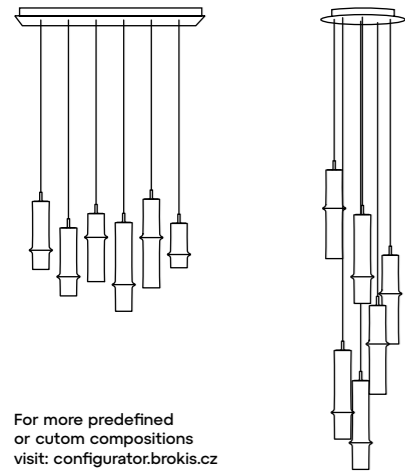

GLASS COLOUR

In glossy surface.



light smoke grey – transparent glass

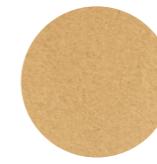

smoke brown – transparent glass

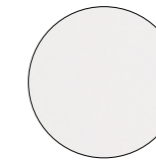

opaline – transparent glass



olive green – transparent glass

BODY FINISH

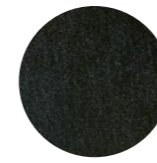

black anodized

CANOPY FINISH

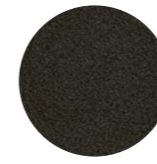

metal – black matte powder coating with structure

TRIMLESS

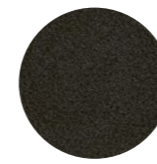

trimless – cable version – black structure

CABLE COLOUR

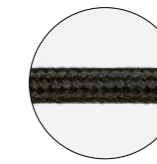

textile cable – black

TROTTOLA



Trottola is a collection of suspension and table lights whose shape elicit memories of a popular childhood toy – the spinning top. The aesthetics of the design are carried on an enchanting luminance that passes through an opal diffuser and opaline glass to reveal a playful contrast of shadows and light. The LED source, visible only from above, is housed in a base clad in pressed aluminium, which in turn is finished in an attractive and durable black anodize. Brightness

can be adjusted with a simple turn of the elegant dimmer. Trottola offers two sizes of suspension and table lights in handblown opaline glass. The table variant is fitted with the innovative BROKIS connector, which makes it easy to disconnect the light and move it about the interior and also facilitates disassembly for maintenance. The collection has been expanded with a wall version called Trottola Applique, which can also be installed on the ceiling.

DESIGN

FEDERICO PERI





PH10971



PH10969

archiproducts
AWARDS
WINNER

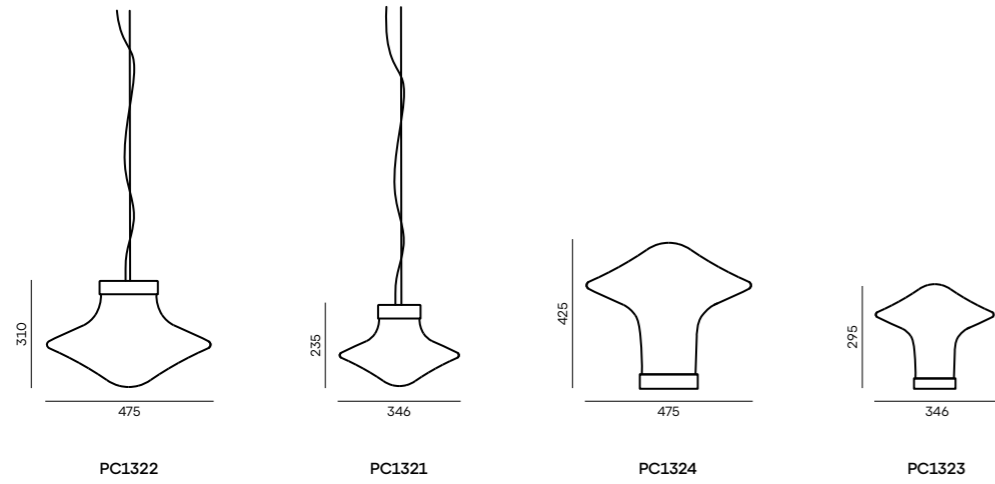

PC1322

PC1321

PC1324

PC1323

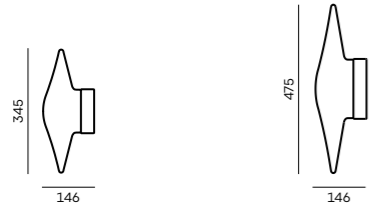

PC1403

PC1404

Canopy

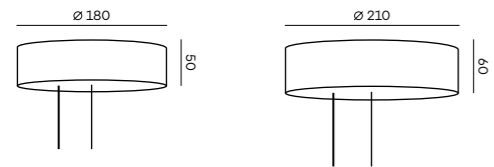

Canopy for PWM dimming system

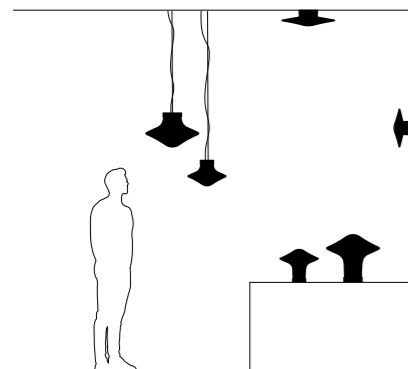

GLASS COLOUR

In glossy surface.

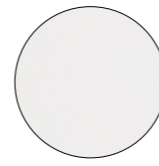

opaline - transparent glass

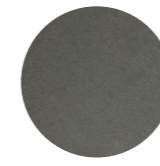

pearl grey - opaline glass

BODY FINISH

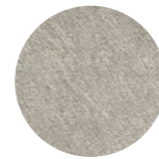

silver anodized



black anodized

CANOPY FINISH

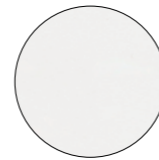

metal - white matte powder coating with structure



metal - black matte powder coating with structure

CABLE COLOUR

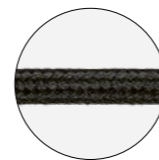

textile cable - black

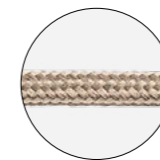

textile cable - light grey

ELO



Elo, an innovative new suspension light combining the distinctive textures of BROKISGLASS with elegant aluminium framing, comprises three articulated arches, the outer two of which can be locked in different attitudes. The unique solution offers a variety of striking scenographic compositions that can shape the interior and lend it a dominant design element. The name Elo means 'ring' or 'bond', words that adeptly express the grand decorative potential and remarkable variability of the concept,

DESIGN

a sculptresque entity that can be modified and customized as the demands of the setting evolve. The glass is set in elegant metal frames crafted from aluminium, which ensures outstanding structural integrity. Illumination is provided by flexible LEDs that follow the curvature of the arches, underscoring the intrinsic aesthetic beauty of the BROKISGLASS and effecting a charming diffusion of light no matter what configuration the piece is installed in.

FILIPPO MAMBRETTI



archiproducts[®]
AWARDS
WINNER
SUSTAINABILITY



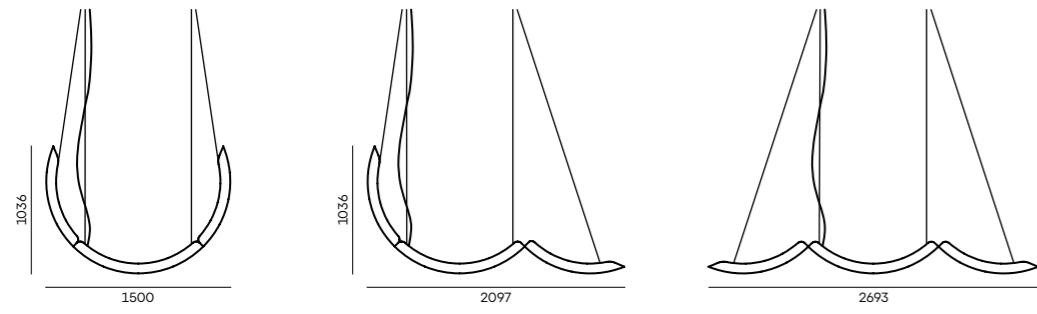

PC1326

Canopy

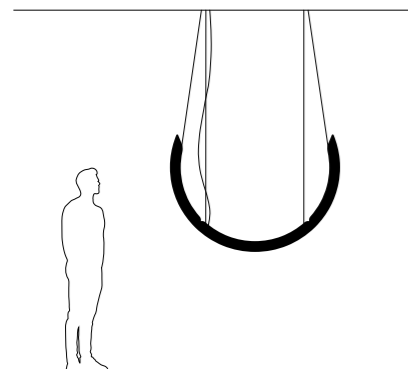
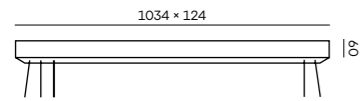

GLASS COLOUR

Possible in glossy finish (front face) and acid-etched finish (front face).



triplex opal
BROKISGLASS



smoke grey
BROKISGLASS

BODY / CANOPY FINISH

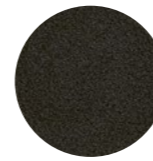

metal - black matte
powder coating with
structure

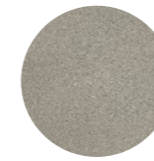

sandblasted aluminium
transparent powder
coating

CABLE COLOUR

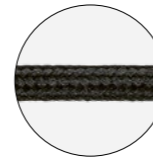

textile cable - black

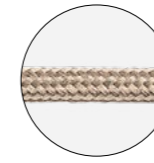

textile cable - light grey

IMPORTANT INFORMATION

BROKIS products and services can be found on the latest version of our website – www.brokis.cz. Our sales partners are regularly informed of news and any changes to products and/or services. In order to streamline cooperation with our sales partners and promote sales of our products and services, we've created new marketing tools, which are available through the MY BROKIS partner platform at www.mybrokis.cz. These tools, which include ordering, informative documents, PR materials, and an overview of complementary services, support product sales growth and help us develop. BROKIS is also introducing optional product registration, which will allow customers to verify the authenticity of their lights. More information on product registration can be found in a special QR code at the end of the catalogue.

Complete specification for each photo/PH below:



LINKTREE



Linktree is a platform that brings all important links together in one place.

LINKTREE SOCIAL MEDIA



BROKIS STORYLINE



BROKISGLASS



BROKIS SOLUTIONS



MY BROKIS



TECHNICAL INFORMATION ABOUT PRODUCTS



cleaning information and unpacking the box



technical information



product registration

BROKIS, s.r.o.

OFFICE

Španielova 1315/25
163 00 Prague 6
Czech Republic

SHOWROOM

Sídlíště Janštejn 39
588 52 Horní Dubenky
Czech Republic

www.brokis.cz

info@brokis.cz

DESIGNERS

Lucie Koldova
Dan Yeffet
Boris Klimek
Chiaromonte Marin
Fumie Shibata
Lenka Damová
Vrtiška & Žák
LCM MARIN design
studio
Federico Peri
Filippo Mambretti
Simona Sbordone

PHOTO

Martin Chum
Adéla Havelková
Max Zambelli

VISUALISATION

Polygoniq
Studio Salaris
Suprema

GRAPHIC DESIGN

Studio Marvil

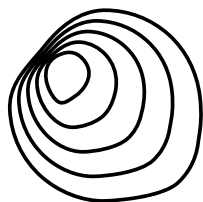

BROKIS®